

# Solutionbank

## Edexcel AS and A Level Modular Mathematics

### Exercise A, Question 1

#### Question:

Simplify:

(a)  $\frac{4x + 4}{x + 1}$

(b)  $\frac{2x - 1}{6x - 3}$

(c)  $\frac{x + 4}{x + 2}$

(d)  $\frac{x + \frac{1}{2}}{4x + 2}$

(e)  $\frac{4x + 2y}{6x + 3y}$

(f)  $\frac{a + 3}{a + 6}$

(g)  $\frac{5p - 5q}{10p - 10q}$

(h)  $\frac{\frac{1}{2}a + b}{2a + 4b}$

(i)  $\frac{x^2}{x^2 + 3x}$

(j)  $\frac{x^2 - 3x}{x^2 - 9}$

(k)  $\frac{x^2 + 5x + 4}{x^2 + 8x + 16}$

$$(l) \frac{x^3 - 2x^2}{x^2 - 4}$$

$$(m) \frac{x^2 - 4}{x^2 + 4}$$

$$(n) \frac{x + 2}{x^2 + 5x + 6}$$

$$(o) \frac{2x^2 - 5x - 3}{2x^2 - 7x - 4}$$

$$(p) \frac{\frac{1}{2}x^2 + x - 4}{\frac{1}{4}x^2 + \frac{3}{2}x + 2}$$

$$(q) \frac{3x^2 - x - 2}{\frac{1}{2}x + \frac{1}{3}}$$

$$(r) \frac{x^2 - 5x - 6}{\frac{1}{3}x - 2}$$

### Solution:

(a)

$$\frac{4x + 4}{x + 1} = \frac{4x \times \cancel{(x+1)}}{1x \times \cancel{(x+1)}} = \frac{4}{1} = 4$$

(b)

$$\frac{2x - 1}{6x - 3} = \frac{1 \times \cancel{(2x-1)}}{3 \times \cancel{(2x-1)}} = \frac{1}{3}$$

(c)  $\frac{x + 4}{x + 2}$  will not simplify any further

(d)

$$\frac{x + 12 \times 2}{4x + 2 \times 2} = \frac{2x + 1}{8x + 4} = \frac{1 \times \cancel{(2x+1)}}{4 \times \cancel{(2x+1)}} = \frac{1}{4}$$

(e)

$$\frac{4x+2y}{6x+3y} = \frac{2(2x+y)}{3(2x+y)} = \frac{2}{3}$$

(f)  $\frac{a+3}{a+6}$  will not simplify any further

(g)

$$\frac{5p-5q}{10p-10q} = \frac{5(p-q)}{10(p-q)} = \frac{5^1}{10_2} = \frac{1}{2}$$

(h)

$$\frac{12a+b \times 2}{2a+4b \times 2} = \frac{a+2b}{4a+8b} = \frac{1 \times (a+2b)}{4 \times (a+2b)} = \frac{1}{4}$$

(i)

$$\frac{x^2}{x^2+3x} = \frac{\cancel{x} \times x}{\cancel{x}(x+3)} = \frac{x}{x+3}$$

(j)

$$\frac{x^2-3x}{x^2-9} = \frac{x(x-3)}{(x+3)(x-3)} = \frac{x}{x+3}$$

(k)

$$\frac{x^2+5x+4}{x^2+8x+16} = \frac{(x+1)(x+4)}{(x+4)(x+4)} = \frac{x+1}{x+4}$$

(l)

$$\frac{x^3-2x^2}{x^2-4} = \frac{x^2(x-2)}{(x+2)(x-2)} = \frac{x^2}{x+2}$$

(m)  $\frac{x^2-4}{x^2+4}$  will not simplify any further. The denominator doesn't factorise.

(n)

$$\frac{x+2}{x^2+5x+6} = \frac{1 \times (x+2)}{(x+3)(x+2)} = \frac{1}{x+3}$$

(o)

$$\frac{2x^2-5x-3}{2x^2-7x-4} = \frac{(2x+1)(x-3)}{(2x+1)(x-4)} = \frac{x-3}{x-4}$$

(p)

$$\frac{12x^2 + x - 4}{14x^2 - 32x + 2} \times 4 = \frac{2x^2 + 4x - 16}{x^2 + 6x + 8} = \frac{2(x-2)\cancel{(x+4)}}{(x+2)\cancel{(x+4)}} = \frac{2(x-2)}{x+2}$$

(q)

$$\frac{3x^2 - x - 2}{12x + 13} \times 6 = \frac{6(3x^2 - x - 2)}{3x + 2} = \frac{6\cancel{(3x+2)}(x-1)}{1 \times \cancel{(3x+2)}} = 6(x-1)$$

(r)

$$\frac{x^2 - 5x - 6}{13x - 2} \times 3 = \frac{3(x^2 - 5x - 6)}{x - 6} = \frac{3(x+1)\cancel{(x-6)}}{1 \times \cancel{(x-6)}} = 3(x+1)$$

© Pearson Education Ltd 2008

# Solutionbank

## Edexcel AS and A Level Modular Mathematics

### Exercise B, Question 1

#### Question:

Simplify:

$$(a) \frac{a}{d} \times \frac{a}{c}$$

$$(b) \frac{a^2}{c} \times \frac{c}{a}$$

$$(c) \frac{2}{x} \times \frac{x}{4}$$

$$(d) \frac{3}{x} \div \frac{6}{x}$$

$$(e) \frac{4}{xy} \div \frac{x}{y}$$

$$(f) \frac{2r^2}{5} \div \frac{4}{r^3}$$

$$(g) \left( x + 2 \right) \times \frac{1}{x^2 - 4}$$

$$(h) \frac{1}{a^2 + 6a + 9} \times \frac{a^2 - 9}{2}$$

$$(i) \frac{x^2 - 3x}{y^2 + y} \times \frac{y + 1}{x}$$

$$(j) \frac{y}{y + 3} \div \frac{y^2}{y^2 + 4y + 3}$$

$$(k) \frac{x^2}{3} \div \frac{2x^3 - 6x^2}{x^2 - 3x}$$

$$(l) \frac{4x^2 - 25}{4x - 10} \div \frac{2x + 5}{8}$$

$$(m) \frac{x+3}{x^2+10x+25} \times \frac{x^2+5x}{x^2+3x}$$

$$(n) \frac{3y^2+4y-4}{10} \div \frac{3y+6}{15}$$

$$(o) \frac{x^2+2xy+y^2}{2} \times \frac{4}{(x-y)^2}$$

**Solution:**

$$(a) \frac{a}{d} \times \frac{a}{c} = \frac{a \times a}{d \times c} = \frac{a^2}{cd}$$

(b)

$$\frac{\cancel{a^2}^1 \times \cancel{a^1}_1}{\cancel{a^1}_1 \times \cancel{a^1}_1} = \frac{a \times 1}{1 \times 1} = a$$

(c)

$$\frac{\cancel{2^1}_1 \times \cancel{1^1}_2}{\cancel{1^1}_1 \times \cancel{2^1}_2} = \frac{1 \times 1}{1 \times 2} = \frac{1}{2}$$

(d)

$$\frac{3}{x} \div \frac{6}{x} = \frac{\cancel{3^1}_1 \times \cancel{1^1}_6}{\cancel{1^1}_1 \times \cancel{6^1}_2} = \frac{1 \times 1}{1 \times 2} = \frac{1}{2}$$

(e)

$$\frac{4}{xy} \div \frac{x}{y} = \frac{4}{x \cancel{y^1}_1} \times \frac{\cancel{y^1}_1}{x} = \frac{4 \times 1}{x \times x} = \frac{4}{x^2}$$

(f)

$$\frac{2r^2}{5} \div \frac{4}{r^3} = \frac{\cancel{2^1}_5 \times \cancel{r^2}_4}{5} \times \frac{r^3}{\cancel{4^1}_2} = \frac{r^5}{10}$$

(g)

$$(x+2) \times \frac{1}{x^2-4} = \frac{x+2^1}{1} = \frac{1}{(\cancel{x+2^1}_1)(x-2)} = \frac{1 \times 1}{1 \times (x-2)} = \frac{1}{x-2}$$

(h)

$$\frac{1}{a^2+6a+9} \times \frac{a^2-9}{2} = \frac{1}{(\cancel{a+3^1})(a+3)} \times \frac{(\cancel{a+3^1})(a-3)}{2} = \frac{a-3}{2(a+3)}$$

(i)

$$\frac{x^2 - 3x}{y^2 + y} \times \frac{y+1}{x} = \frac{\cancel{x^1}(x-3)}{y(y+1)\cancel{1}_1} \times \frac{(y+1)\cancel{1}}{\cancel{x^1}_1} = \frac{x-3}{y}$$

(j)

$$\frac{y}{y+3} \div \frac{y^2}{y^2+4y+3} = \frac{y}{y+3} \times \frac{y^2+4y+3}{y^2} = \frac{\cancel{y}}{y+3} \times \frac{(y+1)\cancel{(y+3)}}{y^2} = \frac{y+1}{y}$$

(k)

$$\frac{x^2}{3} \div \frac{2x^3 - 6x^2}{x^2 - 3x} = \frac{x^2}{3} \times \frac{x^2 - 3x}{2x^3 - 6x^2} = \frac{\cancel{x^2}^1}{3} \times \frac{x(x-3)\cancel{1}}{2\cancel{x^2}(x-3)\cancel{1}_1} = \frac{1 \times x}{3 \times 2} = \frac{x}{6}$$

(l)

$$\frac{4x^2 - 25}{4x - 10} \div \frac{2x + 5}{8} = \frac{4x^2 - 25}{4x - 10} \times \frac{8}{2x + 5} = \frac{(2x+5)\cancel{(2x-5)}^1}{2\cancel{(2x-5)}_1} \times \frac{8}{\cancel{(2x+5)}_1} = \frac{1 \times 8}{2 \times 1} = 4$$

(m)

$$\frac{x+3}{x^2+10x+25} \times \frac{x^2+5x}{x^2+3x} = \frac{\cancel{x+3}^1}{(x+5)\cancel{1}_1(x+5)} \times \frac{\cancel{x^1}(x+5)\cancel{1}}{\cancel{x^1}_1(x+3)\cancel{1}_1} = \frac{1}{x+5}$$

(n)

$$\frac{3y^2+4y-4}{10} \div \frac{3y+6}{15} = \frac{3y^2+4y-4}{10} \times \frac{15}{3y+6} = \frac{(3y-2)\cancel{(y+2)}^1}{10\cancel{2}_2} \times \frac{\cancel{15}^3}{\cancel{3}(y+2)\cancel{1}_1} = \frac{3y-2}{2}$$

(o)

$$\frac{x^2+2xy+y^2}{2} \times \frac{4}{(x-y)^2} = \frac{(x+y)^2}{\cancel{2}_1} \times \frac{\cancel{4}^2}{(x-y)^2} = \frac{2(x+y)^2}{(x-y)^2}$$

# Solutionbank

## Edexcel AS and A Level Modular Mathematics

### Exercise C, Question 1

#### Question:

Simplify:

(a)  $\frac{1}{p} + \frac{1}{q}$

(b)  $\frac{a}{b} - 1$

(c)  $\frac{1}{2x} + \frac{1}{x}$

(d)  $\frac{3}{x^2} - \frac{1}{x}$

(e)  $\frac{3}{4x} + \frac{1}{8x}$

(f)  $\frac{x}{y} + \frac{y}{x}$

(g)  $\frac{1}{x+2} - \frac{1}{x+1}$

(h)  $\frac{2}{x+3} - \frac{1}{x-2}$

(i)  $\frac{1}{3} (x + 2) - \frac{1}{2} (x + 3)$

(j)  $\frac{3x}{(x+4)^2} - \frac{1}{(x+4)}$

(k)  $\frac{1}{2(x+3)} + \frac{1}{3(x-1)}$

(l)  $\frac{2}{x^2 + 2x + 1} + \frac{1}{x+1}$



$$(m) \frac{3}{x^2 + 3x + 2} - \frac{2}{x^2 + 4x + 4}$$

$$(n) \frac{2}{a^2 + 6a + 9} - \frac{3}{a^2 + 4a + 3}$$

$$(o) \frac{2}{y^2 - x^2} + \frac{3}{y - x}$$

$$(p) \frac{x + 2}{x^2 - x - 12} - \frac{x + 1}{x^2 + 5x + 6}$$

$$(q) \frac{3x + 1}{(x + 2)^3} - \frac{2}{(x + 2)^2} + \frac{4}{(x + 2)}$$

**Solution:**

$$(a) \frac{1}{p} + \frac{1}{q} = \frac{q}{pq} + \frac{p}{pq} = \frac{q + p}{pq}$$

$$(b) \frac{a}{b} - 1 = \frac{a}{b} - \frac{1}{1} = \frac{a}{b} - \frac{b}{b} = \frac{a - b}{b}$$

$$(c) \frac{1}{2x} + \frac{1}{x} = \frac{1}{2x} + \frac{2}{2x} = \frac{1 + 2}{2x} = \frac{3}{2x}$$

$$(d) \frac{3}{x^2} - \frac{1}{x} = \frac{3}{x^2} - \frac{x}{x^2} = \frac{3 - x}{x^2}$$

$$(e) \frac{3}{4x} + \frac{1}{8x} = \frac{6}{8x} + \frac{1}{8x} = \frac{7}{8x}$$

$$(f) \frac{x}{y} + \frac{y}{x} = \frac{x^2}{xy} + \frac{y^2}{xy} = \frac{x^2 + y^2}{xy}$$

$$(g) \frac{1}{(x + 2)} - \frac{1}{(x + 1)} = \frac{x + 1}{(x + 2)(x + 1)} - \frac{x + 2}{(x + 2)(x + 1)} =$$

$$\frac{(x + 1) - (x + 2)}{(x + 2)(x + 1)} = \frac{-1}{(x + 2)(x + 1)}$$

$$\begin{aligned} \text{(h)} \quad \frac{2}{(x+3)} - \frac{1}{(x-2)} &= \frac{2(x-2)}{(x+3)(x-2)} - \frac{(x+3)}{(x+3)(x-2)} = \\ &= \frac{x-7}{(x+3)(x-2)} \end{aligned}$$

$$\begin{aligned} \text{(i)} \quad \frac{1}{3}(x+2) - \frac{1}{2}(x+3) &= \frac{x+2}{3} - \frac{x+3}{2} = \frac{2(x+2)}{6} - \frac{3(x+3)}{6} = \\ &= \frac{-x-5}{6} \end{aligned}$$

$$\text{(j)} \quad \frac{3x}{(x+4)^2} - \frac{1}{(x+4)} = \frac{3x}{(x+4)^2} - \frac{x+4}{(x+4)^2} = \frac{3x-(x+4)}{(x+4)^2} = \frac{2x-4}{(x+4)^2}$$

$$\begin{aligned} \text{(k)} \quad \frac{1}{2(x+3)} + \frac{1}{3(x-1)} &= \frac{3(x-1)}{6(x+3)(x-1)} + \frac{2(x+3)}{6(x+3)(x-1)} \\ &= \frac{3(x-1) + 2(x+3)}{6(x+3)(x-1)} \\ &= \frac{5x+3}{6(x+3)(x-1)} \end{aligned}$$

$$\begin{aligned} \text{(l)} \quad \frac{2}{x^2+2x+1} + \frac{1}{x+1} &= \frac{2}{(x+1)^2} + \frac{1}{(x+1)} \\ &= \frac{2}{(x+1)^2} + \frac{x+1}{(x+1)^2} \\ &= \frac{2+x+1}{(x+1)^2} \\ &= \frac{x+3}{(x+1)^2} \end{aligned}$$

$$\begin{aligned} \text{(m)} \quad \frac{3}{x^2+3x+2} - \frac{2}{x^2+4x+4} &= \frac{3}{(x+1)(x+2)} - \frac{2}{(x+2)^2} \\ &= \frac{3(x+2)}{(x+1)(x+2)^2} - \frac{2(x+1)}{(x+1)(x+2)^2} \end{aligned}$$

$$= \frac{3(x+2) - 2(x+1)}{(x+1)(x+2)^2}$$

$$= \frac{x+4}{(x+1)(x+2)^2}$$

$$(n) \frac{2}{a^2+6a+9} - \frac{3}{a^2+4a+3}$$

$$= \frac{2}{(a+3)^2} - \frac{3}{(a+1)(a+3)}$$

$$= \frac{2(a+1)}{(a+1)(a+3)^2} - \frac{3(a+3)}{(a+1)(a+3)^2}$$

$$= \frac{2(a+1) - 3(a+3)}{(a+1)(a+3)^2}$$

$$= \frac{-a-7}{(a+1)(a+3)^2}$$

$$(o) \frac{2}{y^2-x^2} + \frac{3}{y-x}$$

$$= \frac{2}{(y+x)(y-x)} + \frac{3}{(y-x)}$$

$$= \frac{2}{(y+x)(y-x)} + \frac{3(y+x)}{(y+x)(y-x)}$$

$$= \frac{2+3(y+x)}{(y+x)(y-x)}$$

$$= \frac{2+3y+3x}{(y+x)(y-x)}$$

$$(p) \frac{x+2}{x^2-x-12} - \frac{x+1}{x^2+5x+6}$$

$$= \frac{x+2}{(x-4)(x+3)} - \frac{x+1}{(x+3)(x+2)}$$

$$= \frac{(x+2)(x+2)}{(x+2)(x+3)(x-4)} - \frac{(x+1)(x-4)}{(x+2)(x+3)(x-4)}$$

$$= \frac{(x^2+4x+4) - (x^2-3x-4)}{(x+2)(x+3)(x-4)}$$

$$= \frac{7x+8}{(x+2)(x+3)(x-4)}$$

$$\begin{aligned} \text{(q)} \quad & \frac{3x+1}{(x+2)^3} - \frac{2}{(x+2)^2} + \frac{4}{(x+2)} \\ &= \frac{3x+1}{(x+2)^3} - \frac{2(x+2)}{(x+2)^3} + \frac{4(x+2)^2}{(x+2)^3} \\ &= \frac{(3x+1) - (2x+4) + 4(x^2+4x+4)}{(x+2)^3} \\ &= \frac{4x^2+17x+13}{(x+2)^3} \end{aligned}$$

© Pearson Education Ltd 2008

# Solutionbank

## Edexcel AS and A Level Modular Mathematics

### Exercise D, Question 1

#### Question:

Express the following improper fractions in 'mixed' number form by: (i) using long division, (ii) using the remainder theorem

(a)  $\frac{x^3 + 2x^2 + 3x - 4}{x - 1}$

(b)  $\frac{2x^3 + 3x^2 - 4x + 5}{x + 3}$

(c)  $\frac{x^3 - 8}{x - 2}$

(d)  $\frac{2x^2 + 4x + 5}{x^2 - 1}$

(e)  $\frac{8x^3 + 2x^2 + 5}{2x^2 + 2}$

(f)  $\frac{4x^3 - 5x^2 + 3x - 14}{x^2 + 2x - 1}$

(g)  $\frac{x^4 + 3x^2 - 4}{x^2 + 1}$

(h)  $\frac{x^4 - 1}{x + 1}$

(i)  $\frac{2x^4 + 3x^3 - 2x^2 + 4x - 6}{x^2 + x - 2}$

#### Solution:

(a) (i)

$$\begin{array}{r}
 x^2 + 3x + 6 \\
 x-1 \overline{) x^3 + 2x^2 + 3x - 4} \\
 \underline{x^3 - x^2} \phantom{+ 3x - 4} \\
 3x^2 + 3x \phantom{- 4} \\
 \underline{3x^2 - 3x} \phantom{- 4} \\
 6x - 4 \\
 \underline{6x - 6} \\
 2
 \end{array}$$

(ii) Let  $x^3 + 2x^2 + 3x - 4 \equiv (Ax^2 + Bx + C)(x - 1) + R$

Let  $x = 1$

$$1 + 2 + 3 - 4 = (A + B + C) \times 0 + R$$

$$\Rightarrow 2 = R$$

Equate terms in  $x^3 \Rightarrow 1 = A$

Equate terms in  $x^2$

$$\Rightarrow 2 = -A + B \quad (\text{substitute } A = 1)$$

$$\Rightarrow 2 = -1 + B$$

$$\Rightarrow B = 3$$

Equate constant terms

$$\Rightarrow -4 = -C + R \quad (\text{substitute } R = 2)$$

$$\Rightarrow -4 = -C + 2$$

$$\Rightarrow C = 6$$

Hence  $\frac{x^3 + 2x^2 + 3x - 4}{x - 1} \equiv x^2 + 3x + 6 + \frac{2}{x - 1}$

(b) (i)

$$\begin{array}{r}
 2x^2 - 3x + 5 \\
 x+3 \overline{) 2x^3 + 3x^2 - 4x + 5} \\
 \underline{2x^3 + 6x^2} \phantom{- 4x + 5} \\
 -3x^2 - 4x \phantom{+ 5} \\
 \underline{-3x^2 - 9x} \phantom{+ 5} \\
 5x + 5 \\
 \underline{5x + 15} \\
 -10
 \end{array}$$

(ii) Let  $2x^3 + 3x^2 - 4x + 5 \equiv (Ax^2 + Bx + C)(x + 3) + R$

Let  $x = -3$

$$2 \times -27 + 3 \times 9 + 12 + 5 = (9A - 3B + C) \times 0 + R$$

$$\Rightarrow -10 = R$$

Equate terms in  $x^3 \Rightarrow 2 = A$

Equate terms in  $x^2$

$$\Rightarrow 3 = B + 3A \quad (\text{substitute } A = 2)$$

$$\Rightarrow 3 = B + 6$$

$$\Rightarrow B = -3$$

Equate constant terms

$$\Rightarrow 5 = 3C + R \quad (\text{substitute } R = -10)$$

$$\Rightarrow 5 = 3C - 10$$

$$\Rightarrow 3C = 15$$

$$\Rightarrow C = 5$$

Hence 
$$\frac{2x^3 + 3x^2 - 4x + 5}{x + 3} \equiv 2x^2 - 3x + 5 - \frac{10}{x + 3}$$

(c) (i)

$$\begin{array}{r} x^2 + 2x + 4 \\ x - 2 \overline{) x^3 + 0x^2 + 0x - 8} \\ \underline{x^3 - 2x^2} \phantom{+ 0x - 8} \\ 2x^2 + 0x \phantom{- 8} \\ \underline{2x^2 - 4x} \phantom{- 8} \\ 4x - 8 \\ \underline{4x - 8} \\ 0 \end{array}$$

(ii) Let  $x^3 - 8 \equiv (Ax^2 + Bx + C)(x - 2) + R$

Let  $x = 2$

$$8 - 8 = (4A + 2B + C) \times 0 + R$$

$$\Rightarrow 0 = R$$

Equate terms in  $x^3 \Rightarrow 1 = A$

Equate terms in  $x^2$

$$\Rightarrow 0 = B - 2A \quad (\text{substitute } A = 1)$$

$$\Rightarrow 0 = B - 2$$

$$\Rightarrow B = 2$$

Equate constant terms

$$\Rightarrow -8 = -2C + R \quad (\text{substitute } R = 0)$$

$$\Rightarrow -2C = -8$$

$$\Rightarrow C = 4$$

Hence 
$$\frac{x^3 - 8}{x - 2} \equiv x^2 + 2x + 4$$

There is no remainder. So  $(x - 2)$  is a factor.

(d) (i)

$$\begin{array}{r}
 2 \\
 x^2 + 0x - 1 \overline{) 2x^2 + 4x + 5} \\
 \underline{2x^2 + 0x - 2} \\
 4x + 7
 \end{array}$$

$4x + 7$  is 'less than'  $(x^2 - 1)$  so it is the remainder.

(ii) Let

$$2x^2 + 4x + 5 \equiv A(x^2 - 1) + \frac{Bx + C}{1}$$

If the divisor is quadratic then the remainder can be linear.

$$\text{Equate terms in } x^2 \Rightarrow 2 = A$$

$$\text{Equate terms in } x \Rightarrow 4 = B$$

Equate constant terms

$$\Rightarrow 5 = -A + C \quad (\text{substitute } A = 2)$$

$$\Rightarrow 5 = -2 + C$$

$$\Rightarrow C = 7$$

$$\text{Hence } \frac{2x^2 + 4x + 5}{x^2 - 1} \equiv 2 + \frac{4x + 7}{x^2 - 1}$$

(e) (i)

$$\begin{array}{r}
 4x + 1 \\
 2x^2 + 0x + 2 \overline{) 8x^3 + 2x^2 + 0x + 5} \\
 \underline{8x^3 + 0x^2 + 8x} \\
 2x^2 - 8x + 5 \\
 \underline{2x^2 + 0x + 2} \\
 -8x + 3
 \end{array}$$

$$(ii) \text{ Let } 8x^3 + 2x^2 + 5 \equiv (Ax + B)(2x^2 + 2) + Cx + D$$

Equate terms in  $x^3$

$$\Rightarrow 8 = 2A$$

$$\Rightarrow A = 4$$

Equate terms in  $x^2$

$$\Rightarrow 2 = 2B$$

$$\Rightarrow B = 1$$

Equate terms in  $x$

$$\Rightarrow 0 = 2A + C \quad (\text{substitute } A = 4)$$

$$\Rightarrow 0 = 8 + C$$



$$\Rightarrow C = -8$$

Equate constant terms

$$\Rightarrow 5 = 2B + D \quad (\text{substitute } B = 1)$$

$$\Rightarrow 5 = 2 + D$$

$$\Rightarrow D = 3$$

Hence 
$$\frac{8x^3 + 2x^2 + 5}{2x^2 + 2} \equiv 4x + 1 + \frac{-8x + 3}{2x^2 + 2}$$

(f) (i)

$$\begin{array}{r} 4x - 13 \\ x^2 + 2x - 1 \overline{) 4x^3 - 5x^2 + 3x - 14} \\ \underline{4x^3 + 8x^2 - 4x} \phantom{- 14} \\ -13x^2 + 7x - 14 \\ \underline{-13x^2 - 26x + 13} \\ 33x - 27 \end{array}$$

(ii) Let  $4x^3 - 5x^2 + 3x - 14 \equiv (Ax + B)(x^2 + 2x - 1) + Cx + D$

Equate terms in  $x^3 \Rightarrow 4 = A$

Equate terms in  $x^2$

$$\Rightarrow -5 = B + 2A \quad (\text{substitute } A = 4)$$

$$\Rightarrow -5 = B + 8$$

$$\Rightarrow B = -13$$

Equate terms in  $x$

$$\Rightarrow 3 = -A + 2B + C \quad (\text{substitute } A = 4, B = -13)$$

$$\Rightarrow 3 = -4 + (-26) + C$$

$$\Rightarrow C = 33$$

Equate constant terms

$$\Rightarrow -14 = -B + D \quad (\text{substitute } B = -13)$$

$$\Rightarrow -14 = 13 + D$$

$$\Rightarrow D = -27$$

Hence 
$$\frac{4x^3 - 5x^2 + 3x - 14}{x^2 + 2x - 1} \equiv 4x - 13 + \frac{33x - 27}{x^2 + 2x - 1}$$

(g) (i)

$$\begin{array}{r}
 x^2 + 2 \\
 x^2 + 0x + 1 \overline{) x^4 + 0x^3 + 3x^2 + 0x - 4} \\
 \underline{x^4 + 0x^3 + x^2} \phantom{+ 0x - 4} \\
 2x^2 + 0x - 4 \\
 \underline{2x^2 + 0x + 2} \\
 -6
 \end{array}$$

(ii) Let  $x^4 + 3x^2 - 4 \equiv (Ax^2 + Bx + C)(x^2 + 1) + Dx + E$

Equate terms in  $x^4 \Rightarrow 1 = A$

Equate terms in  $x^3 \Rightarrow 0 = B$

Equate terms in  $x^2$

$$\Rightarrow 3 = A + C \quad (\text{substitute } A = 1)$$

$$\Rightarrow 3 = 1 + C$$

$$\Rightarrow C = 2$$

Equate terms in  $x$

$$\Rightarrow 0 = B + D \quad (\text{substitute } B = 0)$$

$$\Rightarrow 0 = 0 + D$$

$$\Rightarrow D = 0$$

Equate constant terms

$$\Rightarrow -4 = C + E \quad (\text{substitute } C = 2)$$

$$\Rightarrow -4 = 2 + E$$

$$\Rightarrow E = -6$$

Hence  $\frac{x^4 + 3x^2 - 4}{x^2 + 1} \equiv x^2 + 2 - \frac{6}{x^2 + 1}$

(h) (i)

$$\begin{array}{r}
 x^3 - x^2 + x - 1 \\
 x + 1 \overline{) x^4 + 0x^3 + 0x^2 + 0x - 1} \\
 \underline{x^4 + x^3} \phantom{+ 0x^2 + 0x - 1} \\
 -x^3 + 0x^2 \phantom{+ 0x - 1} \\
 \underline{-x^3 - x^2} \phantom{+ 0x - 1} \\
 x^2 + 0x \phantom{+ 0x - 1} \\
 \underline{x^2 + x} \phantom{+ 0x - 1} \\
 -x - 1 \phantom{+ 0x - 1} \\
 \underline{-x - 1} \\
 0
 \end{array}$$

There is no remainder so  $(x + 1)$  is a factor of  $x^4 - 1$ .

(ii) Let  $x^4 - 1 \equiv (Ax^3 + Bx^2 + Cx + D)(x + 1) + E$

Let  $x = -1$

$$(-1)^4 - 1 = (-A + B - C + D) \times 0 + E$$

$$\Rightarrow E = 0$$

Equate terms in  $x^4 \Rightarrow 1 = A$

Equate terms in  $x^3$

$$\Rightarrow 0 = A + B \quad (\text{substitute } A = 1)$$

$$\Rightarrow 0 = 1 + B$$

$$\Rightarrow B = -1$$

Equate terms in  $x^2$

$$\Rightarrow 0 = B + C \quad (\text{substitute } B = -1)$$

$$\Rightarrow 0 = -1 + C$$

$$\Rightarrow C = 1$$

Equate terms in  $x$

$$\Rightarrow 0 = D + C \quad (\text{substitute } C = 1)$$

$$\Rightarrow 0 = D + 1$$

$$\Rightarrow D = -1$$

Hence  $\frac{x^4 - 1}{x + 1} \equiv x^3 - x^2 + x - 1$

(i) (i)

$$\begin{array}{r} 2x^2 + x + 1 \\ x^2 + x - 2 \overline{) 2x^4 + 3x^3 - 2x^2 + 4x - 6} \\ \underline{2x^4 + 2x^3 - 4x^2} \phantom{+ 4x - 6} \\ x^3 + 2x^2 + 4x \phantom{- 6} \\ \underline{x^3 + x^2 - 2x} \phantom{- 6} \\ x^2 + 6x - 6 \\ \underline{x^2 + x - 2} \\ 5x - 4 \end{array}$$

(ii) Let  $2x^4 + 3x^3 - 2x^2 + 4x - 6 \equiv (Ax^2 + Bx + C)(x^2 + x - 2) + Dx + E$

Equate terms in  $x^4 \Rightarrow 2 = A$

Equate terms in  $x^3$

$$\Rightarrow 3 = A + B \quad (\text{substitute } A = 2)$$

$$\Rightarrow 3 = 2 + B$$

$$\Rightarrow B = 1$$

Equate terms in  $x^2$

$$\Rightarrow -2 = -2A + B + C \quad (\text{substitute } A = 2, B = 1)$$

$$\Rightarrow -2 = -4 + 1 + C$$

$$\Rightarrow C = 1$$

Equate terms in  $x$

$$\Rightarrow 4 = C - 2B + D \quad (\text{substitute } C = 1, B = 1)$$

$$\Rightarrow 4 = 1 - 2 + D$$

$$\Rightarrow D = 5$$

Equate constant terms

$$\Rightarrow -6 = -2C + E \quad (\text{substitute } C = 1)$$

$$\Rightarrow -6 = -2 + E$$

$$\Rightarrow E = -4$$

Hence 
$$\frac{2x^4 + 3x^3 - 2x^2 + 4x - 6}{x^2 + x - 2} \equiv 2x^2 + x + 1 + \frac{5x - 4}{x^2 + x - 2}$$

# Solutionbank

## Edexcel AS and A Level Modular Mathematics

### Exercise D, Question 2

#### Question:

Find the value of the constants  $A$ ,  $B$ ,  $C$ ,  $D$  and  $E$  in the following identity:

$$3x^4 - 4x^3 - 8x^2 + 16x - 2 \equiv (Ax^2 + Bx + C)(x^2 - 3) + Dx + E$$

#### Solution:

$$3x^4 - 4x^3 - 8x^2 + 16x - 2 \equiv (Ax^2 + Bx + C)(x^2 - 3) + Dx + E$$

$$\text{Equate terms in } x^4 \Rightarrow 3 = A$$

$$\text{Equate terms in } x^3 \Rightarrow -4 = B$$

Equate terms in  $x^2$

$$\Rightarrow -8 = -3A + C \quad (\text{substitute } A = 3)$$

$$\Rightarrow -8 = -9 + C$$

$$\Rightarrow C = 1$$

Equate terms in  $x$

$$\Rightarrow 16 = -3B + D \quad (\text{substitute } B = -4)$$

$$\Rightarrow 16 = 12 + D$$

$$\Rightarrow D = 4$$

Equate constant terms

$$\Rightarrow -2 = -3C + E \quad (\text{substitute } C = 1)$$

$$\Rightarrow -2 = -3 + E$$

$$\Rightarrow E = 1$$

$$\text{Hence } 3x^4 - 4x^3 - 8x^2 + 16x - 2 \equiv (3x^2 - 4x + 1)(x^2 - 3) + 4x + 1$$

A good idea in equalities is to check with an easy value of  $x$  because it should be true for all values of  $x$ .

$$\text{Substitute } x = 1 \text{ into LHS} \Rightarrow 3 - 4 - 8 + 16 - 2 = 5$$

$$\text{Substitute } x = 1 \text{ into RHS} \Rightarrow \left( \begin{matrix} 3 \\ -4 \\ +1 \end{matrix} \right) \times \left( \begin{matrix} 1 \\ -3 \end{matrix} \right)$$

$$+ 4 + 1 = 0 \times -2 + 4 + 1 = 5 \checkmark$$

# Solutionbank

## Edexcel AS and A Level Modular Mathematics

### Exercise E, Question 1

#### Question:

Simplify the following fractions:

(a)  $\frac{ab}{c} \times \frac{c^2}{a^2}$

(b)  $\frac{x^2 + 2x + 1}{4x + 4}$

(c)  $\frac{x^2 + x}{2} \div \frac{x + 1}{4}$

(d)  $\frac{x + \frac{1}{x} - 2}{x - 1}$

(e)  $\frac{a + 4}{a + 8}$

(f)  $\frac{b^2 + 4b - 5}{b^2 + 2b - 3}$

#### Solution:

(a)

$$\frac{ab}{c} \times \frac{c^2}{a^2} = \frac{b \times c}{a} = \frac{bc}{a}$$

(b)

$$\frac{x^2 + 2x + 1}{4x + 4} = \frac{(x+1)(\cancel{x+1})}{4(\cancel{x+1})} = \frac{x+1}{4}$$

(c)

$$\frac{x^2 + x}{2} \div \frac{x + 1}{4} = \frac{x^2 + x}{2} \times \frac{4}{x + 1} = \frac{x(\cancel{x+1})^1}{\cancel{2}_1} \times \frac{\cancel{4}^2}{(\cancel{x+1})_1} = 2x$$

(d)

$$\frac{x+1x-2}{x-1} \times x = \frac{x^2+1-2x}{x(x-1)} = \frac{(x-1)\cancel{(x-1)}^1}{x\cancel{(x-1)}_1} = \frac{x-1}{x}$$

(e)  $\frac{a+4}{a+8}$  doesn't simplify as there are no common factors.

(f)

$$\frac{b^2+4b-5}{b^2+2b-3} = \frac{(b+5)\cancel{(b-1)}^1}{(b+3)\cancel{(b-1)}_1} = \frac{b+5}{b+3}$$

© Pearson Education Ltd 2008

# Solutionbank

## Edexcel AS and A Level Modular Mathematics

### Exercise E, Question 2

#### Question:

Simplify:

$$(a) \frac{x}{4} + \frac{x}{3}$$

$$(b) \frac{4}{y} - \frac{3}{2y}$$

$$(c) \frac{x+1}{2} - \frac{x-2}{3}$$

$$(d) \frac{x^2 - 5x - 6}{x-1}$$

$$(e) \frac{x^3 + 7x - 1}{x+2}$$

$$(f) \frac{x^4 + 3}{x^2 + 1}$$

#### Solution:

$$(a) \frac{x}{4} + \frac{x}{3} = \frac{3x}{12} + \frac{4x}{12} = \frac{7x}{12}$$

$$(b) \frac{4}{y} - \frac{3}{2y} = \frac{8}{2y} - \frac{3}{2y} = \frac{5}{2y}$$

$$(c) \frac{x+1}{2} - \frac{x-2}{3} = \frac{3(x+1)}{6} - \frac{2(x-2)}{6} = \frac{3(x+1) - 2(x-2)}{6} = \frac{x+7}{6}$$

$$(d) \frac{x^2 - 5x - 6}{x-1} = \frac{(x-6)(x+1)}{(x-1)} \quad \text{No common factors so divide.}$$

$$\begin{array}{r} x-4 \\ x-1 \overline{)x^2 - 5x - 6} \\ \underline{x^2 - 1x} \phantom{-6} \\ -4x - 6 \\ \underline{-4x + 4} \\ -10 \end{array}$$



Hence  $\frac{x^2 - 5x - 6}{x - 1} = x - 4 - \frac{10}{x - 1}$

(e)  $\frac{x^3 + 7x - 1}{x + 2}$

$$\begin{array}{r}
 x^2 - 2x + 11 \\
 x + 2 \overline{) x^3 + 0x^2 + 7x - 1} \\
 \underline{x^3 + 2x^2} \phantom{- 1} \\
 -2x^2 + 7x \phantom{- 1} \\
 \underline{-2x^2 - 4x} \phantom{- 1} \\
 11x - 1 \\
 \underline{11x + 22} \\
 -23
 \end{array}$$

Hence  $\frac{x^3 + 7x - 1}{x + 2} = x^2 - 2x + 11 - \frac{23}{x + 2}$

(f)  $\frac{x^4 + 3}{x^2 + 1}$

$$\begin{array}{r}
 x^2 - 1 \\
 x^2 + 0x + 1 \overline{) x^4 + 0x^3 + 0x^2 + 0x + 3} \\
 \underline{x^4 + 0x^3 + 1x^2} \phantom{+ 0x + 3} \\
 -1x^2 + 0x + 3 \\
 \underline{-1x^2 + 0x - 1} \\
 4
 \end{array}$$

Hence  $\frac{x^4 + 3}{x^2 + 1} = x^2 - 1 + \frac{4}{x^2 + 1}$

# Solutionbank

## Edexcel AS and A Level Modular Mathematics

Exercise E, Question 3

### Question:

Find the value of the constants  $A$ ,  $B$ ,  $C$  and  $D$  in the following identity:

$$x^3 - 6x^2 + 11x + 2 \equiv (x - 2) (Ax^2 + Bx + C) + D$$

### Solution:

$$x^3 - 6x^2 + 11x + 2 \equiv (x - 2) (Ax^2 + Bx + C) + D$$

Let  $x = 2$

$$8 - 24 + 22 + 2 = 0 \times (4A + 2B + C) + D$$

$$\Rightarrow D = 8$$

$$\text{Equate coefficients in } x^3 \Rightarrow 1 = A$$

Equate coefficients in  $x^2$

$$\Rightarrow -6 = -2A + B \quad (\text{substitute } A = 1)$$

$$\Rightarrow -6 = -2 + B$$

$$\Rightarrow B = -4$$

Equate coefficients in  $x$

$$\Rightarrow 11 = C - 2B \quad (\text{substitute } B = -4)$$

$$\Rightarrow 11 = C + 8$$

$$\Rightarrow C = 3$$

$$\text{Hence } x^3 - 6x^2 + 11x + 2 = (x - 2) (x^2 - 4x + 3) + 8$$

**Check.** Equate constant terms:  $2 = -2 \times 3 + 8 \checkmark$

# Solutionbank

## Edexcel AS and A Level Modular Mathematics

### Exercise E, Question 4

#### Question:

$$f(x) = x + \frac{3}{x-1} - \frac{12}{x^2+2x-3} \quad \{ x \in \mathbb{R}, x > 1 \}$$

$$\text{Show that } f(x) = \frac{x^2+3x+3}{x+3}$$

[E]

#### Solution:

$$\begin{aligned} f(x) &= x + \frac{3}{x-1} - \frac{12}{x^2+2x-3} \\ &= \frac{x}{1} + \frac{3}{x-1} - \frac{12}{(x+3)(x-1)} \\ &= \frac{x(x+3)(x-1)}{(x+3)(x-1)} + \frac{3(x+3)}{(x+3)(x-1)} - \frac{12}{(x+3)(x-1)} \\ &= \frac{x(x+3)(x-1) + 3(x+3) - 12}{(x+3)(x-1)} \\ &= \frac{x(x^2+2x-3) + 3x+9-12}{(x+3)(x-1)} \\ &= \frac{x^3+2x^2-3x+3x+9-12}{(x+3)(x-1)} \\ &= \frac{x^3+2x^2-3}{(x+3)(x-1)} \quad [\text{Factorise numerator. } (x-1) \text{ is a factor as } f(1) \\ &= 0.] \\ &= \frac{(x-1)(x^2+3x+3)}{(x+3)(x-1)} \quad (\text{cancel common factors}) \\ &= \frac{x^2+3x+3}{x+3} \end{aligned}$$

# Solutionbank

## Edexcel AS and A Level Modular Mathematics

Exercise E, Question 5

### Question:

Show that  $\frac{x^4 + 2}{x^2 - 1} \equiv x^2 + B + \frac{C}{x^2 - 1}$  for constants  $B$  and  $C$ , which should be found.

### Solution:

We need to find  $B$  and  $C$  such that

$$\frac{x^4 + 2}{x^2 - 1} \equiv x^2 + B + \frac{C}{x^2 - 1}$$

Multiply both sides by  $(x^2 - 1)$  :

$$x^4 + 2 \equiv (x^2 + B)(x^2 - 1) + C$$

$$x^4 + 2 \equiv x^4 + Bx^2 - x^2 - B + C$$

Compare terms in  $x^2$

$$\Rightarrow 0 = B - 1$$

$$\Rightarrow B = 1$$

Compare constant terms

$$\Rightarrow 2 = -B + C \quad (\text{substitute } B = 1)$$

$$\Rightarrow 2 = -1 + C$$

$$\Rightarrow C = 3$$

Hence  $x^4 + 2 \equiv (x^2 + 1)(x^2 - 1) + 3$

So  $\frac{x^4 + 2}{x^2 - 1} = x^2 + 1 + \frac{3}{x^2 - 1}$

# Solutionbank

## Edexcel AS and A Level Modular Mathematics

Exercise E, Question 6

### Question:

Show that  $\frac{4x^3 - 6x^2 + 8x - 5}{2x + 1}$  can be put in the form  $Ax^2 + Bx + C + \frac{D}{2x + 1}$ . Find the values of the constants  $A$ ,  $B$ ,  $C$  and  $D$ .

### Solution:

$$\begin{array}{r}
 2x^2 - 4x + 6 \\
 2x + 1 \overline{) 4x^3 - 6x^2 + 8x - 5} \\
 \underline{4x^3 + 2x^2} \phantom{- 5} \\
 -8x^2 + 8x \phantom{- 5} \\
 \underline{-8x^2 - 4x} \phantom{- 5} \\
 12x - 5 \\
 \underline{12x + 6} \\
 -11
 \end{array}$$

Hence  $\frac{4x^3 - 6x^2 + 8x - 5}{2x + 1} = 2x^2 - 4x + 6 - \frac{11}{2x + 1}$

So  $A = 2$ ,  $B = -4$ ,  $C = 6$  and  $D = -11$

© Pearson Education Ltd 2008

# Solutionbank

## Edexcel AS and A Level Modular Mathematics

Exercise A, Question 1

### Question:

Draw mapping diagrams and graphs for the following operations:

- (a) 'subtract 5' on the set  $\{ 10, 5, 0, -5, x \}$
- (b) 'double and add 3' on the set  $\{ -2, 2, 4, 6, x \}$
- (c) 'square and then subtract 1' on the set  $\{ -3, -1, 0, 1, 3, x \}$
- (d) 'the positive square root' on the set  $\{ -4, 0, 1, 4, 9, x \}$ .

### Solution:

(a)

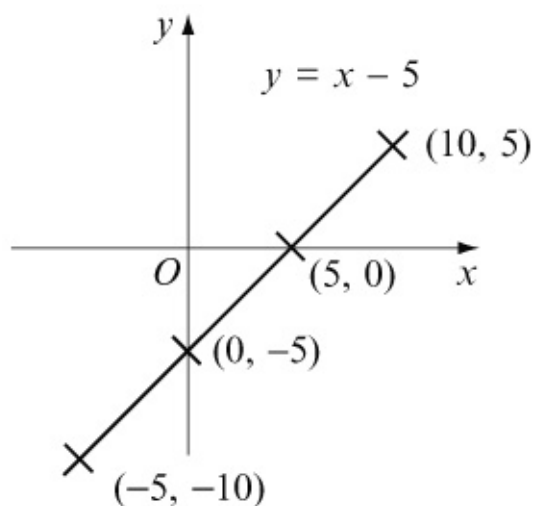
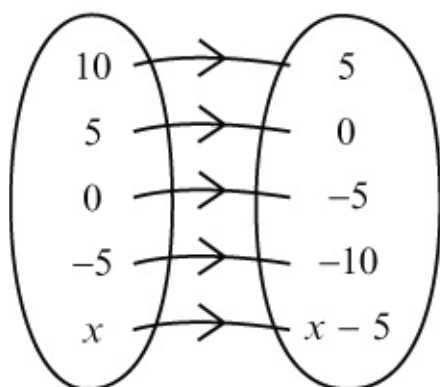

(b)

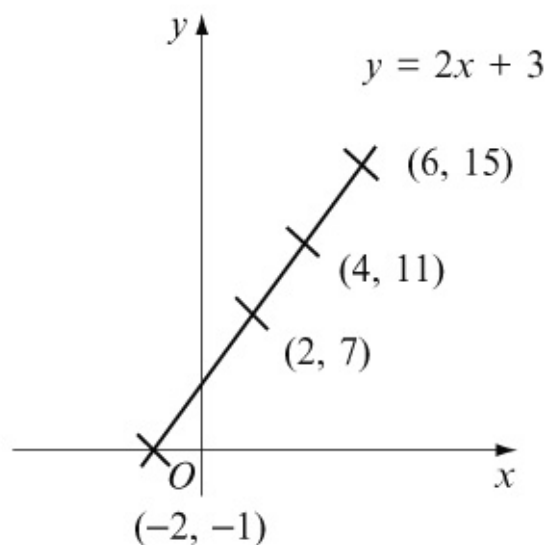
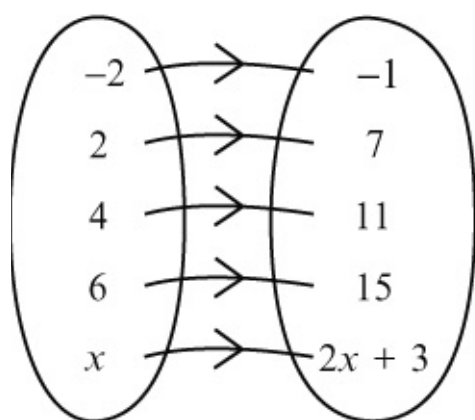

(c)

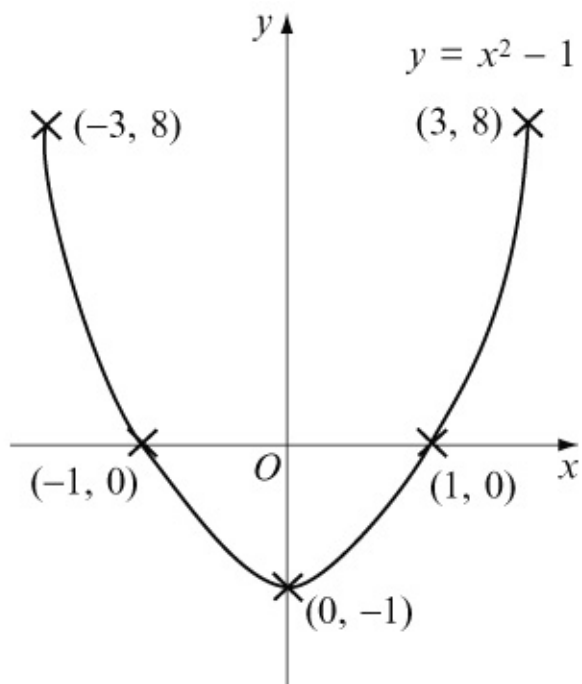
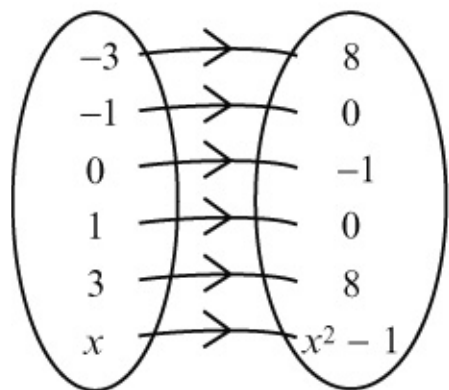

(d)

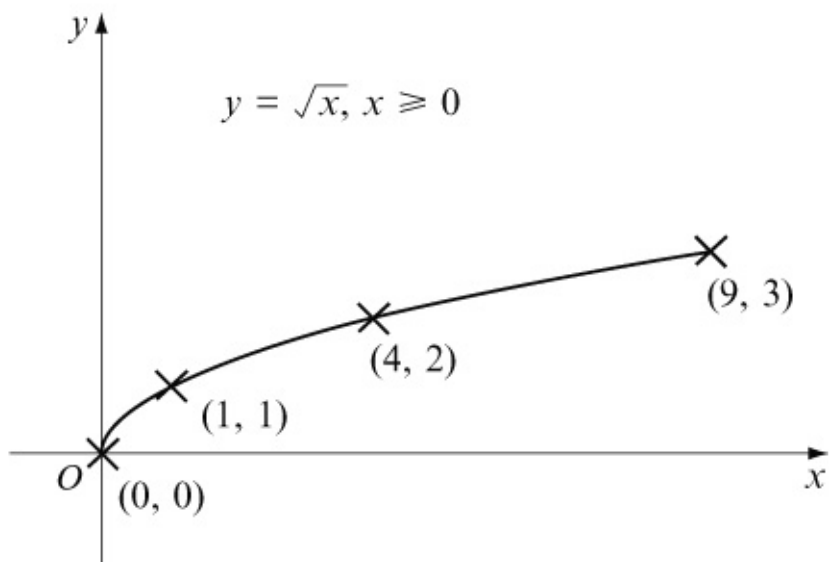
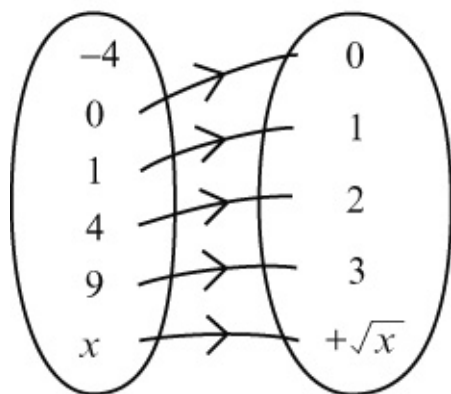

**Note:** You cannot take the square root of a negative number.

# Solutionbank

## Edexcel AS and A Level Modular Mathematics

### Exercise A, Question 2

#### Question:

Find the missing numbers  $a$  to  $h$  in the following mapping diagrams:

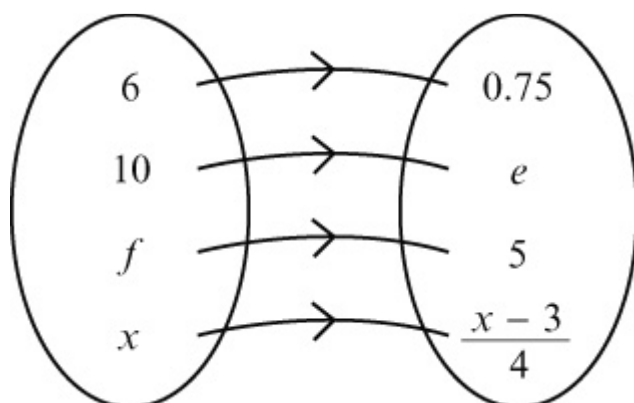
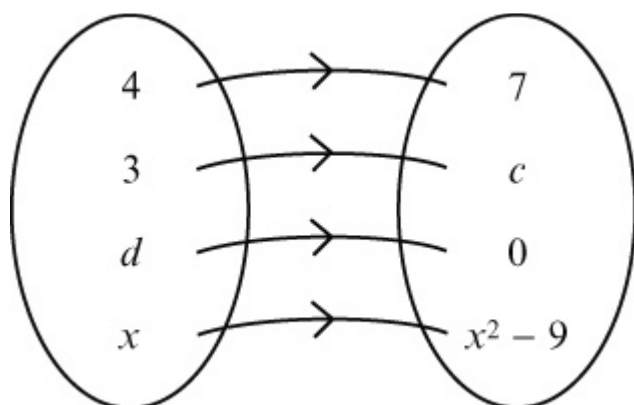
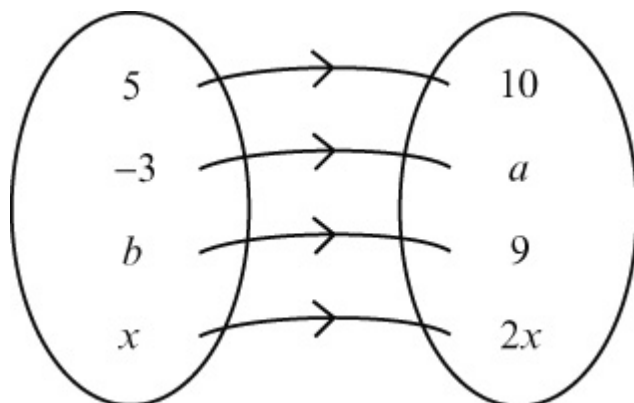

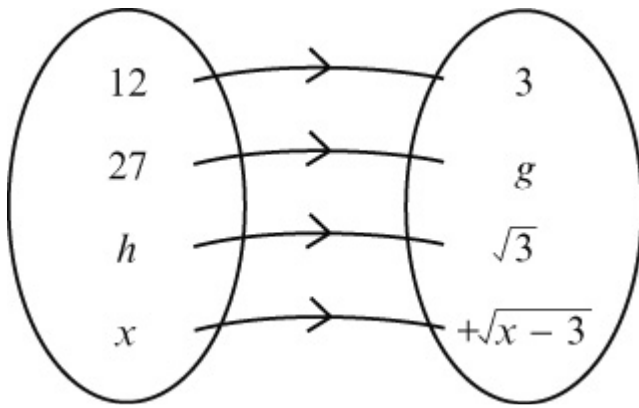

**Solution:**

$$x \rightarrow 2x \quad \text{is 'doubling'}$$

$$-3 \rightarrow a \quad \text{so } a = -6$$

$$b \rightarrow 9 \quad \text{so } b \times 2 = 9 \Rightarrow b = 4 \frac{1}{2}$$

$$x \rightarrow x^2 - 9 \quad \text{is 'squaring then subtracting 9'}$$

$$3 \rightarrow c \quad \text{so } c = 3^2 - 9 = 0$$

$$d \rightarrow 0 \quad \text{so } d^2 - 9 = 0 \Rightarrow d^2 = 9 \Rightarrow d = \pm 3$$

$$x \rightarrow \frac{x-3}{4} \quad \text{is 'subtract 3, then divide by 4'}$$

$$10 \rightarrow e \quad \text{so } e = (10 - 3) \div 4 = 1.75$$

$$f \rightarrow 5 \quad \text{so } \frac{f-3}{4} = 5 \Rightarrow f = 23$$

$$x \rightarrow +\sqrt{x-3} \quad \text{is 'subtract 3, then take the positive square root'}$$

$$27 \rightarrow g \quad \text{so } g = +\sqrt{27-3} = +\sqrt{24} = +2\sqrt{6}$$

$$h \rightarrow +\sqrt{3} \quad \text{so } \sqrt{h-3} = \sqrt{3} \Rightarrow h-3=3 \Rightarrow h=6$$

$$\text{So } a = -6, b = 4 \frac{1}{2}, c = 0, d = \pm 3, e = 1.75, f = 23, g = 2\sqrt{6}, h = 6$$

# Solutionbank

## Edexcel AS and A Level Modular Mathematics

### Exercise B, Question 1

#### Question:

Find:

(a)  $f(3)$  where  $f(x) = 5x + 1$

(b)  $g(-2)$  where  $g(x) = 3x^2 - 2$

(c)  $h(0)$  where  $h : x \rightarrow 3^x$

(d)  $j(-2)$  where  $j : x \rightarrow 2^{-x}$

#### Solution:

(a)  $f(x) = 5x + 1$

Substitute  $x = 3 \Rightarrow f(3) = 5 \times 3 + 1 = 16$

(b)  $g(x) = 3x^2 - 2$

Substitute  $x = -2 \Rightarrow g(-2) = 3 \times (-2)^2 - 2 = 3 \times 4 - 2 = 10$

(c)  $h(x) = 3^x$

Substitute  $x = 0 \Rightarrow h(0) = 3^0 = 1$

(d)  $j(x) = 2^{-x}$

Substitute  $x = -2 \Rightarrow j(-2) = 2^{-(-2)} = 2^2 = 4$

# Solutionbank

## Edexcel AS and A Level Modular Mathematics

### Exercise B, Question 2

#### Question:

Calculate the value(s) of  $a$ ,  $b$ ,  $c$  and  $d$  given that:

(a)  $p(a) = 16$  where  $p(x) = 3x - 2$

(b)  $q(b) = 17$  where  $q(x) = x^2 - 3$

(c)  $r(c) = 34$  where  $r(x) = 2(2^x) + 2$

(d)  $s(d) = 0$  where  $s(x) = x^2 + x - 6$

#### Solution:

(a)  $p(x) = 3x - 2$

Substitute  $x = a$  and  $p(a) = 16$  then

$$16 = 3a - 2$$

$$18 = 3a$$

$$a = 6$$

(b)  $q(x) = x^2 - 3$

Substitute  $x = b$  and  $q(b) = 17$  then

$$17 = b^2 - 3$$

$$20 = b^2$$

$$b = \pm \sqrt{20}$$

$$b = \pm 2\sqrt{5}$$

(c)  $r(x) = 2 \times 2^x + 2$

Substitute  $x = c$  and  $r(c) = 34$  then

$$34 = 2 \times 2^c + 2$$

$$32 = 2 \times 2^c$$

$$16 = 2^c$$

$$c = 4$$

(d)  $s(x) = x^2 + x - 6$

Substitute  $x = d$  and  $s(d) = 0$  then

$$0 = d^2 + d - 6$$

$$0 = (d + 3)(d - 2)$$

$$d = 2, -3$$

# Solutionbank

## Edexcel AS and A Level Modular Mathematics

### Exercise B, Question 3

#### Question:

For the following functions

(i) sketch the graph of the function

(ii) state the range

(iii) describe if the function is one-to-one or many-to-one.

(a)  $m(x) = 3x + 2$

(b)  $n(x) = x^2 + 5$

(c)  $p(x) = \sin(x)$

(d)  $q(x) = x^3$

#### Solution:

(a)  $m(x) = 3x + 2$

(i)

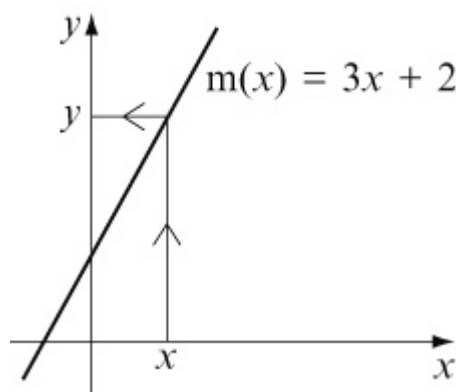

(ii) Range of  $m(x)$  is  $-\infty < m(x) < \infty$

or  $m(x) \in \mathbb{R}$  (all of the real numbers)

(iii) Function is one-to-one

(b)  $n(x) = x^2 + 5$

(i)

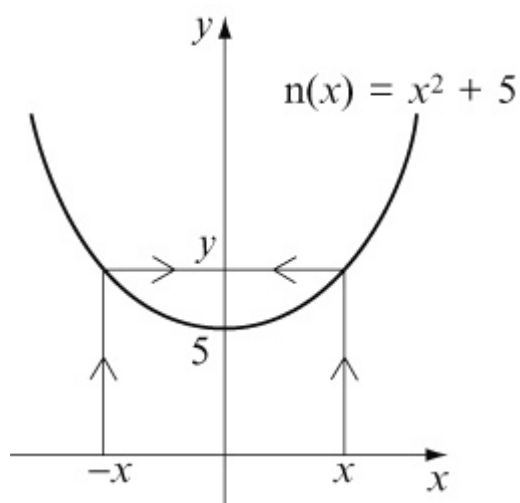

(ii) Range of  $n(x)$  is  $n(x) \geq 5$

(iii) Function is many-to-one

(c)  $p(x) = \sin(x)$

(i)

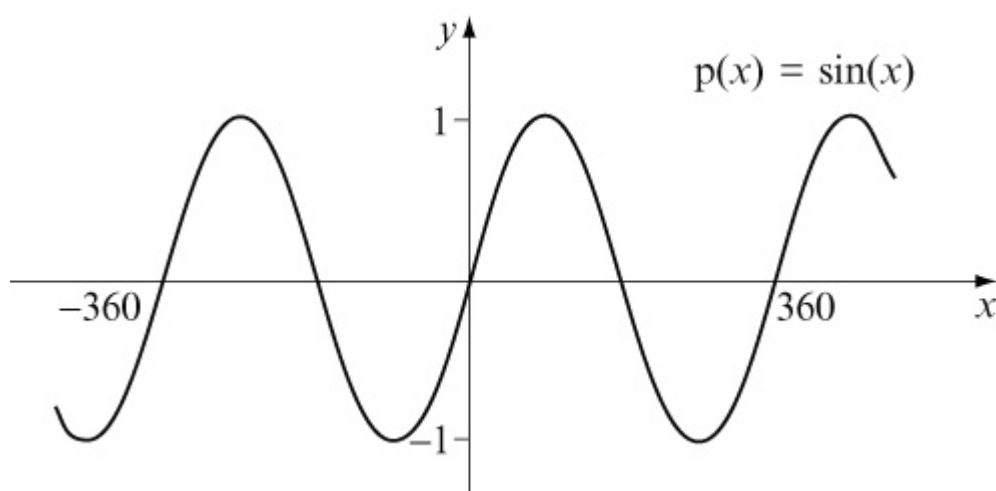

(ii) Range of  $p(x)$  is  $-1 \leq p(x) \leq 1$

(iii) Function is many-to-one

(d)  $q(x) = x^3$

(i)

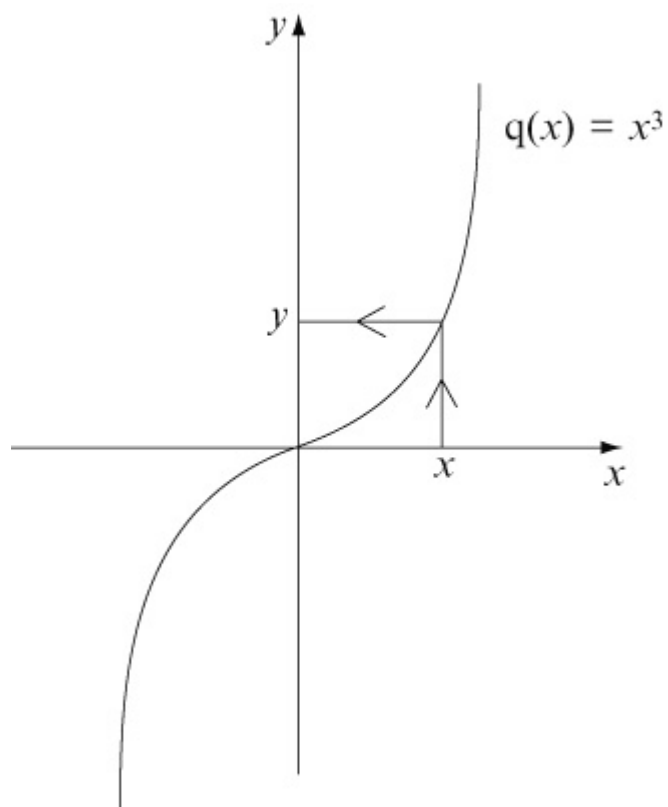

(ii) Range of  $q(x)$  is  $-\infty < q(x) < \infty$  or  $q(x) \in \mathbb{R}$

(iii) Function is one-to-one

© Pearson Education Ltd 2008

# Solutionbank

## Edexcel AS and A Level Modular Mathematics

### Exercise B, Question 4

#### Question:

State whether or not the following graphs represent functions. Give reasons for your answers and describe the type of function.

(a)

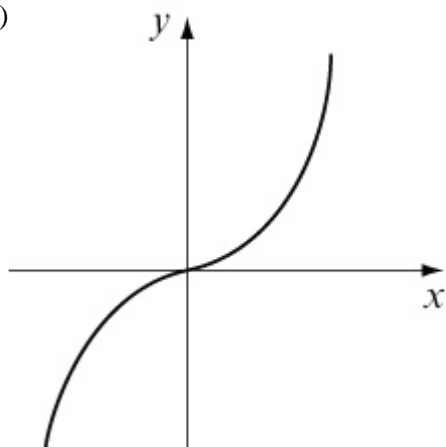

(b)

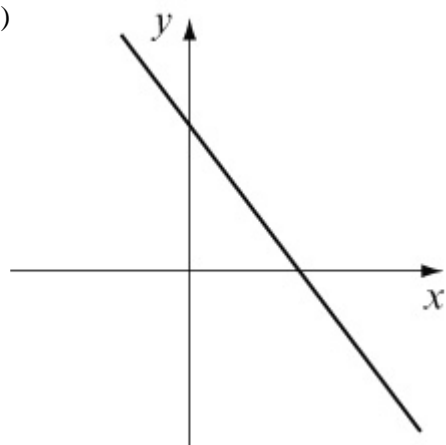

(c)

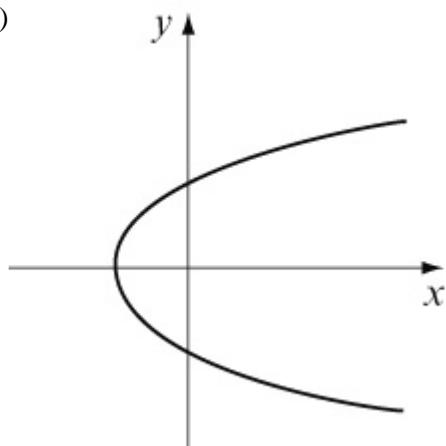

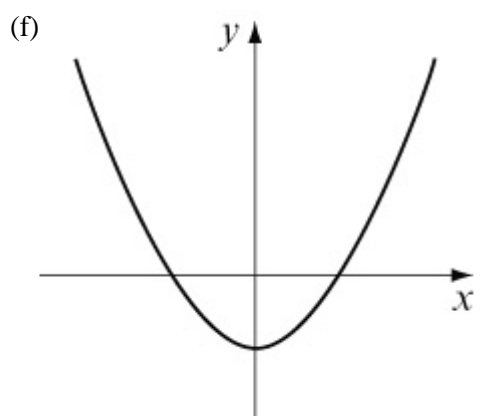
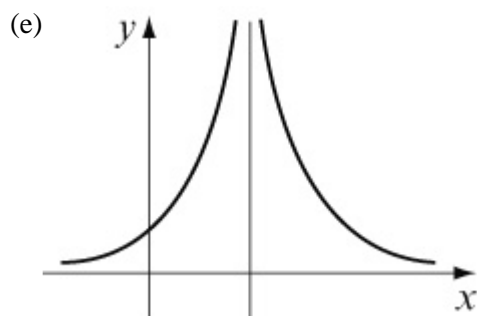
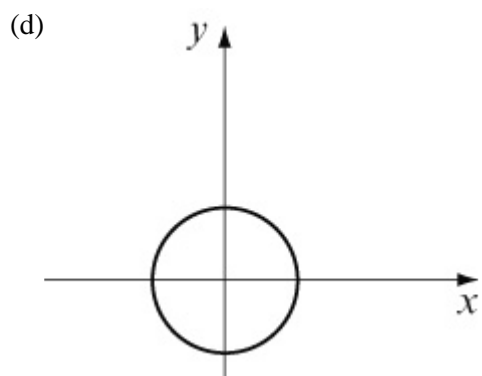

**Solution:**

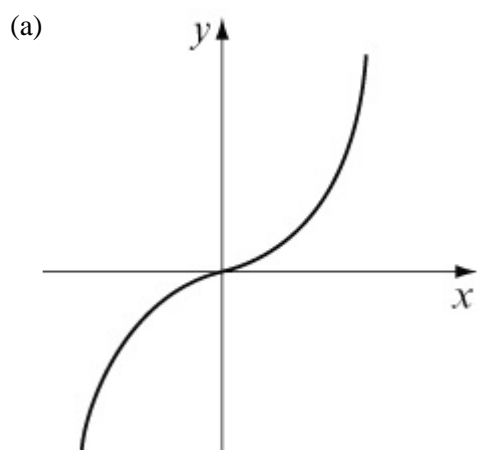

One-to-one function



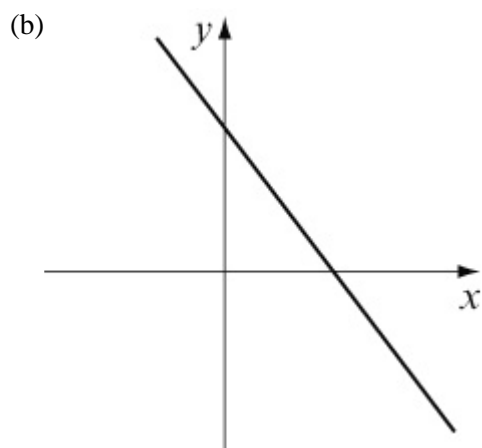

One-to-one function

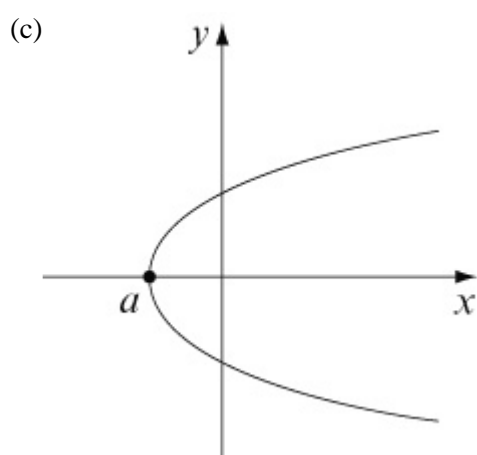

Not a function.

The values left of  $x = a$  do not get mapped anywhere.  
The values right of  $x = a$  get mapped to two values of  $y$ .

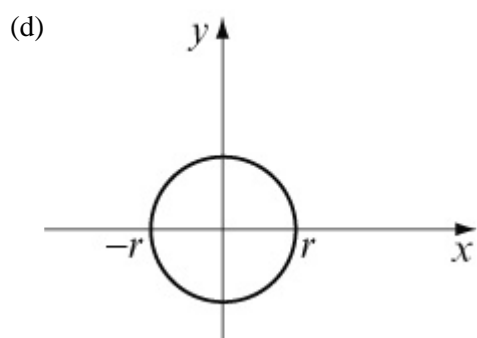

Not a function. Similar to part (c).

Values of  $x$  between  $-r$  and  $+r$  get mapped to two values of  $y$ .  
Values outside this don't get mapped anywhere.

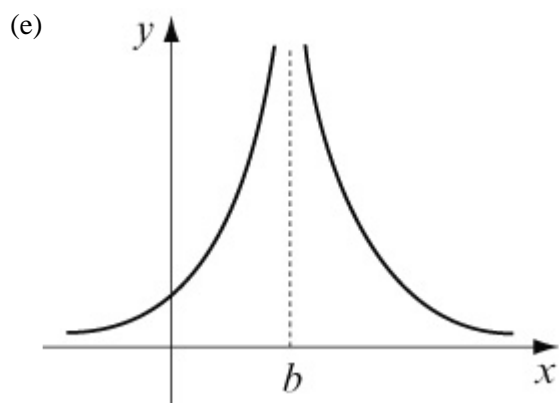

Not a function. The value  $x = b$  doesn't get mapped anywhere.

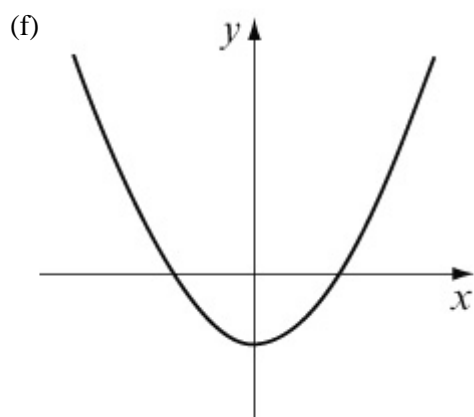

Many-to-one function. Two values of  $x$  get mapped to the same value of  $y$ .

# Solutionbank

## Edexcel AS and A Level Modular Mathematics

### Exercise C, Question 1

#### Question:

The functions below are defined for the discrete domains.

(i) Represent each function on a mapping diagram, writing down the elements in the range.

(ii) State if the function is one-to-one or many-to-one.

(a)  $f(x) = 2x + 1$  for the domain  $\{x = 1, 2, 3, 4, 5\}$ .

(b)  $g(x) = +\sqrt{x}$  for the domain  $\{x = 1, 4, 9, 16, 25, 36\}$ .

(c)  $h(x) = x^2$  for the domain  $\{x = -2, -1, 0, 1, 2\}$ .

(d)  $j(x) = \frac{2}{x}$  for the domain  $\{x = 1, 2, 3, 4, 5\}$ .

#### Solution:

(a)  $f(x) = 2x + 1$  'Double and add 1'

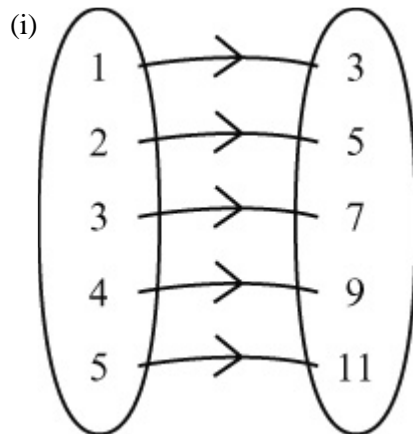

(ii) One-to-one function

(b)  $g(x) = +\sqrt{x}$  'The positive square root'

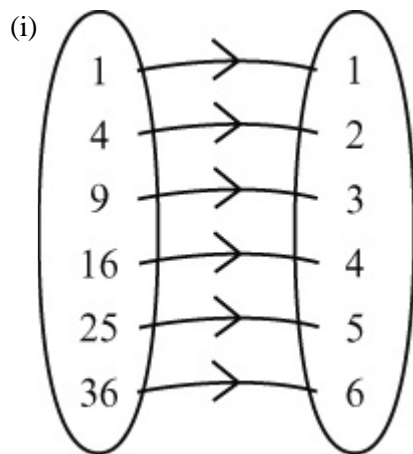

(ii) One-to-one function

(c)  $h(x) = x^2$  'Square the numbers in the domain'

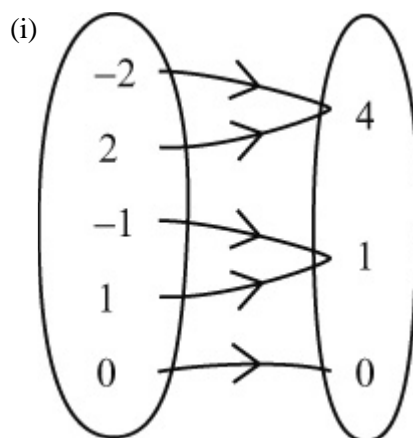

(ii) Many-to-one function

(d)  $j(x) = \frac{2}{x}$  '2 divided by numbers in the domain'

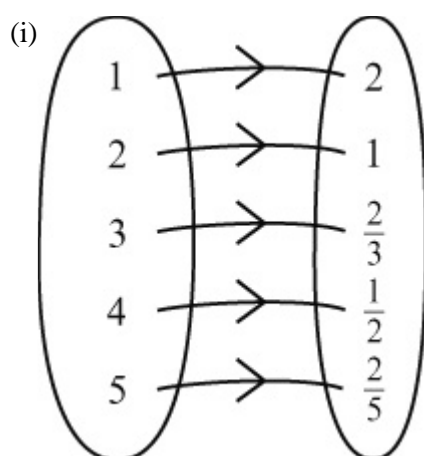

(ii) One-to-one function



# Solutionbank

## Edexcel AS and A Level Modular Mathematics

### Exercise C, Question 2

#### Question:

The functions below are defined for continuous domains.

- Represent each function on a graph.
- State the range of the function.
- State if the function is one-to-one or many-to-one.

(a)  $m(x) = 3x + 2$  for the domain  $\{x > 0\}$ .

(b)  $n(x) = x^2 + 5$  for the domain  $\{x \geq 2\}$ .

(c)  $p(x) = 2 \sin x$  for the domain  $\{0 \leq x \leq 180\}$ .

(d)  $q(x) = +\sqrt{x+2}$  for the domain  $\{x \geq -2\}$ .

#### Solution:

(a)  $m(x) = 3x + 2$  for  $x > 0$

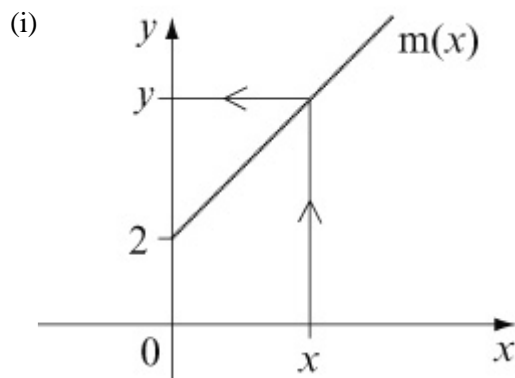

$3x + 2$  is a linear function of gradient 3 passing through 2 on the y axis.

(ii)  $x = 0$  does not exist in the domain

So range is  $m(x) > 3 \times 0 + 2 \Rightarrow m(x) > 2$

(iii)  $m(x)$  is a one-to-one function

(b)  $n(x) = x^2 + 5$  for  $x \geq 2$

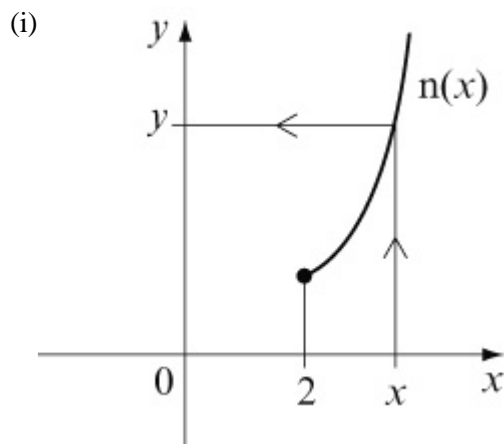

$x^2 + 5$  is a parabola with minimum point at  $(0, 5)$ .

The domain however is only values bigger than or equal to 2.

(ii)  $x = 2$  exists in the domain

So range is  $n(x) \geq 2^2 + 5 \Rightarrow n(x) \geq 9$

(iii)  $n(x)$  is a one-to-one function

(c)  $p(x) = 2 \sin x$  for  $0 \leq x \leq 180$

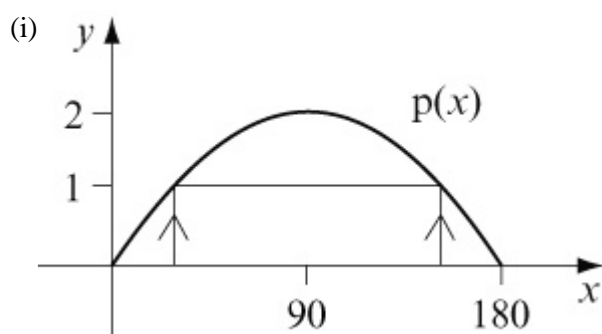

$2 \sin x$  has the same shape as  $\sin x$  except that it has been stretched by a factor of 2 parallel to the y axis.

(ii) Range of  $p(x)$  is  $0 \leq p(x) \leq 2$

(iii) The function is many-to-one

(d)  $q(x) = +\sqrt{x+2}$  for  $x \geq -2$

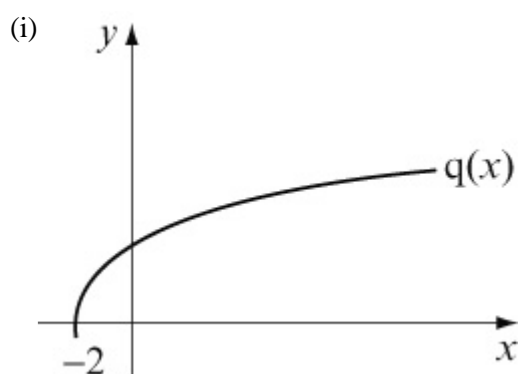

$\sqrt{x+2}$  is the  $\sqrt{x}$  graph translated 2 units to the left.

(ii) The range of  $q(x)$  is  $q(x) \geq 0$

(iii) The function is one-to-one

© Pearson Education Ltd 2008



# Solutionbank

## Edexcel AS and A Level Modular Mathematics

### Exercise C, Question 3

#### Question:

The mappings  $f(x)$  and  $g(x)$  are defined by

$$f(x) = \begin{cases} 4 - x & x < 4 \\ x^2 + 9x & \geq 4 \end{cases}$$

$$g(x) = \begin{cases} 4 - x & x < 4 \\ x^2 + 9x & > 4 \end{cases}$$

Explain why  $f(x)$  is a function and  $g(x)$  is not.  
Sketch the function  $f(x)$  and find

- $f(3)$
- $f(10)$
- the value(s) of  $a$  such that  $f(a) = 90$ .

#### Solution:

$4 - x$  is a linear function of gradient  $-1$  passing through  $4$  on the  $y$  axis.

$x^2 + 9x$  is a  $\cup$ -shaped quadratic

At  $x = 4$   $4 - x = 0$  and  $x^2 + 9 = 25$

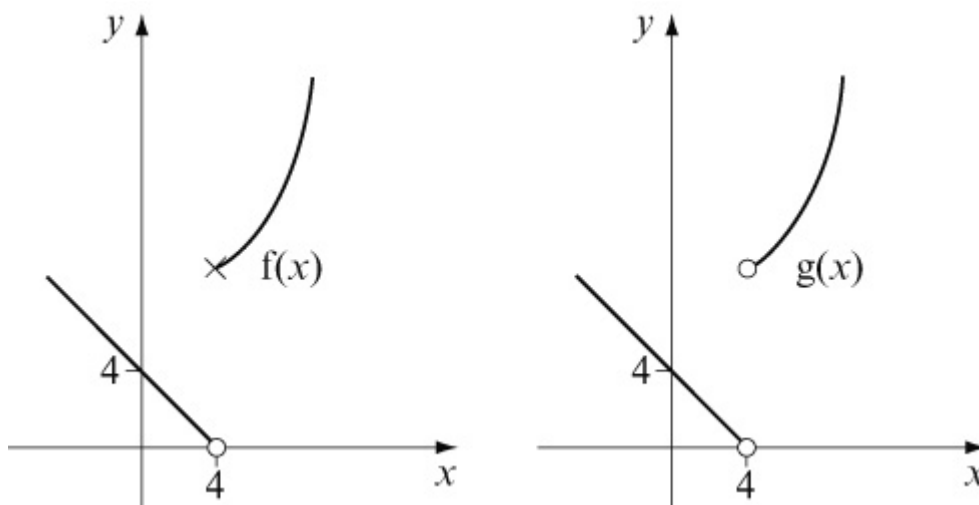

$g(x)$  is not a function because the element  $4$  of the domain does not get mapped anywhere.

In  $f(x)$  it gets mapped to  $25$ .

(a)  $f(3) = 4 - 3 = 1$  (Use  $4 - x$  as  $3 < 4$ )

(b)  $f(10) = 10^2 + 9 = 109$  (Use  $x^2 + 9$  as  $10 > 4$ )

(c)

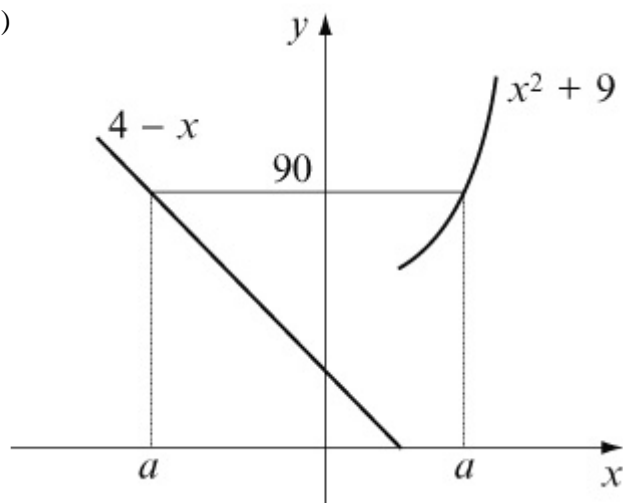

The negative value of  $a$  is where  $4 - a = 90 \Rightarrow a = -86$

The positive value of  $a$  is where

$$a^2 + 9 = 90$$

$$a^2 = 81$$

$$a = \pm 9$$

$$a = 9$$

The values of  $a$  are  $-86$  and  $9$ .

# Solutionbank

## Edexcel AS and A Level Modular Mathematics

### Exercise C, Question 4

#### Question:

The function  $s(x)$  is defined by

$$s(x) = \begin{cases} x^2 - 6 & x < 0 \\ 10 - x & x \geq 0 \end{cases}$$

- (a) Sketch  $s(x)$ .
- (b) Find the value(s) of  $a$  such that  $s(a) = 43$ .
- (c) Find the values of the domain that get mapped to themselves in the range.

#### Solution:

- (a)  $x^2 - 6$  is a  $\cup$ -shaped quadratic with a minimum value of  $(0, -6)$ .  
 $10 - x$  is a linear function with gradient  $-1$  passing through  $10$  on the  $y$  axis.

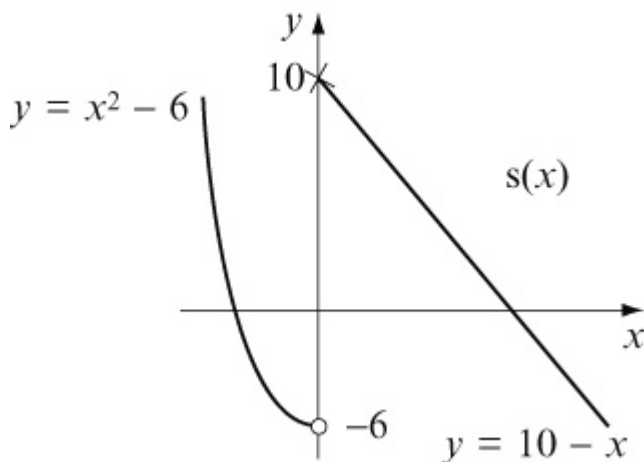

- (b) There is only one value of  $a$  such that  $s(a) = 43$  (see graph).

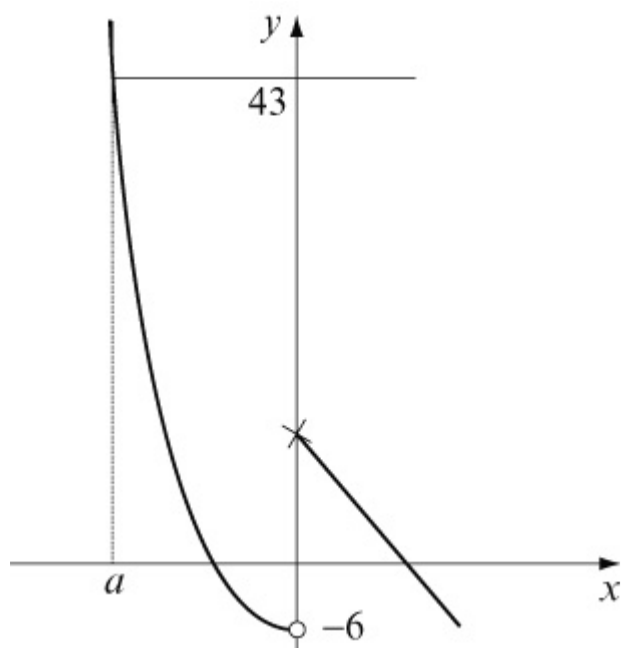

$$s(a) = 43$$

$$a^2 - 6 = 43$$

$$a^2 = 49$$

$$a = \pm 7$$

Value is negative so  $a = -7$

(c) If value gets mapped to itself then  $s(b) = b$

For  $10 - x$  part

$$10 - b = b$$

$$\Rightarrow 10 = 2b$$

$$\Rightarrow b = 5$$

**Check.**  $s(5) = 10 - 5 = 5 \checkmark$

For  $x^2 - 6$  part

$$b^2 - 6 = b$$

$$\Rightarrow b^2 - b - 6 = 0$$

$$\Rightarrow (b - 3)(b + 2) = 0$$

$$\Rightarrow b = 3, -2$$

$b$  must be negative

$$\Rightarrow b = -2$$

**Check.**  $s(-2) = (-2)^2 - 6 = 4 - 6 = -2 \checkmark$

Values that get mapped to themselves are  $-2$  and  $5$ .

# Solutionbank

## Edexcel AS and A Level Modular Mathematics

Exercise C, Question 5

### Question:

The function  $g(x)$  is defined by  $g(x) = cx + d$  where  $c$  and  $d$  are constants to be found. Given  $g(3) = 10$  and  $g(8) = 12$  find the values of  $c$  and  $d$ .

### Solution:

$$g(x) = cx + d$$

$$g(3) = 10 \Rightarrow c \times 3 + d = 10$$

$$g(8) = 12 \Rightarrow c \times 8 + d = 12$$

$$3c + d = 10 \quad \textcircled{1}$$

$$8c + d = 12 \quad \textcircled{2}$$

$$\textcircled{2} - \textcircled{1}: \quad 5c = 2 \quad (\div 5)$$

$$\Rightarrow c = 0.4$$

Substitute  $c = 0.4$  into  $\textcircled{1}$ :

$$3 \times 0.4 + d = 10$$

$$1.2 + d = 10$$

$$d = 8.8$$

$$\text{Hence } g(x) = 0.4x + 8.8$$

# Solutionbank

## Edexcel AS and A Level Modular Mathematics

Exercise C, Question 6

### Question:

The function  $f(x)$  is defined by  $f(x) = ax^3 + bx - 5$  where  $a$  and  $b$  are constants to be found. Given that  $f(1) = -4$  and  $f(2) = 9$ , find the values of the constants  $a$  and  $b$ .

### Solution:

$$f(x) = ax^3 + bx - 5$$

$$f(1) = -4 \Rightarrow a \times 1^3 + b \times 1 - 5 = -4$$

$$\Rightarrow a + b - 5 = -4$$

$$\Rightarrow a + b = 1 \quad \textcircled{1}$$

$$f(2) = 9 \Rightarrow a \times 2^3 + b \times 2 - 5 = 9$$

$$\Rightarrow 8a + 2b - 5 = 9$$

$$\Rightarrow 8a + 2b = 14$$

$$\Rightarrow 4a + b = 7 \quad \textcircled{2}$$

$$\textcircled{2} - \textcircled{1}: \quad 3a = 6$$

$$\Rightarrow a = 2$$

Substitute  $a = 2$  in  $\textcircled{1}$ :

$$2 + b = 1$$

$$b = -1$$

# Solutionbank

## Edexcel AS and A Level Modular Mathematics

Exercise C, Question 7

### Question:

The function  $h(x)$  is defined by  $h(x) = x^2 - 6x + 20$   $\{ x \geq a \}$ . Given that  $h(x)$  is a one-to-one function find the smallest possible value of the constant  $a$ .

### Solution:

$$h(x) = x^2 - 6x + 20 = (x - 3)^2 - 9 + 20 = (x - 3)^2 + 11$$

This is a  $\cup$ -shaped quadratic with minimum point at  $(3, 11)$ .

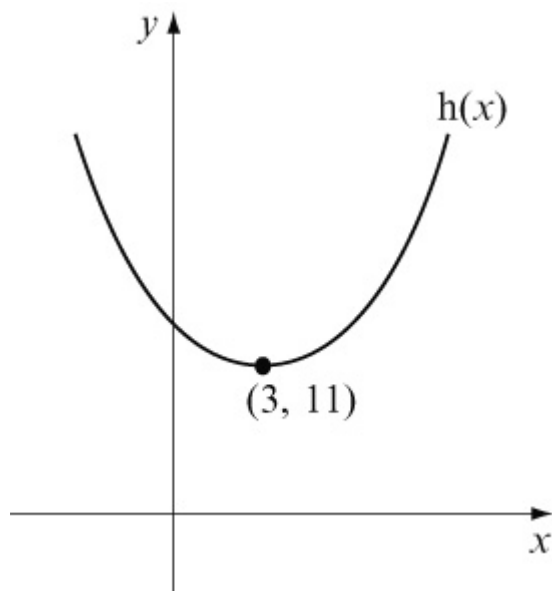

This is a many-to-one function.

For  $h(x)$  to be one-to-one,  $x \geq 3$

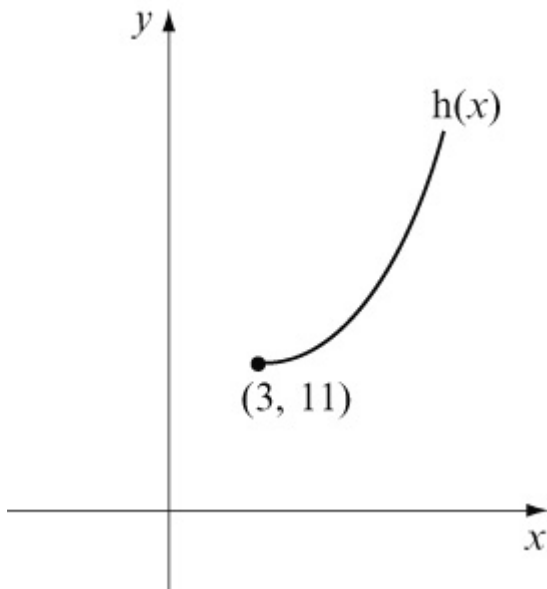

Hence smallest value of  $a$  is 3.

© Pearson Education Ltd 2008



# Solutionbank

## Edexcel AS and A Level Modular Mathematics

### Exercise D, Question 1

#### Question:

Given the functions  $f(x) = 4x + 1$ ,  $g(x) = x^2 - 4$  and  $h(x) = \frac{1}{x}$ , find expressions for the functions:

(a)  $fg(x)$

(b)  $gf(x)$

(c)  $gh(x)$

(d)  $fh(x)$

(e)  $f^2(x)$

#### Solution:

(a)  $fg(x) = f(x^2 - 4) = 4(x^2 - 4) + 1 = 4x^2 - 15$

(b)  $gf(x) = g(4x + 1) = (4x + 1)^2 - 4 = 16x^2 + 8x - 3$

(c)  $gh(x) = g\left(\frac{1}{x}\right) = \left(\frac{1}{x}\right)^2 - 4 = \frac{1}{x^2} - 4$

(d)  $fh(x) = f\left(\frac{1}{x}\right) = 4 \times \left(\frac{1}{x}\right) + 1 = \frac{4}{x} + 1$

(e)  $f^2(x) = ff(x) = f(4x + 1) = 4(4x + 1) + 1 = 16x + 5$

# Solutionbank

## Edexcel AS and A Level Modular Mathematics

### Exercise D, Question 2

#### Question:

For the following functions  $f(x)$  and  $g(x)$ , find the composite functions  $fg(x)$  and  $gf(x)$ . In each case find a suitable domain and the corresponding range when

(a)  $f(x) = x - 1, g(x) = x^2$

(b)  $f(x) = x - 3, g(x) = +\sqrt{x}$

(c)  $f(x) = 2^x, g(x) = x + 3$

#### Solution:

(a)  $f(x) = x - 1, g(x) = x^2$

$$fg(x) = f(x^2) = x^2 - 1$$

Domain  $x \in \mathbb{R}$

Range  $fg(x) \geq -1$

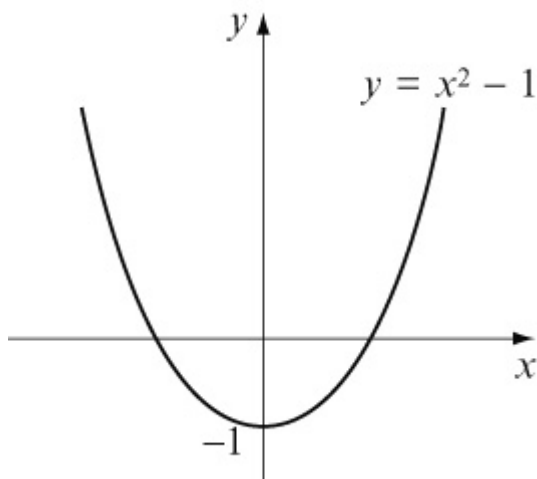

$$gf(x) = g(x - 1) = (x - 1)^2$$

Domain  $x \in \mathbb{R}$

Range  $gf(x) \geq 0$

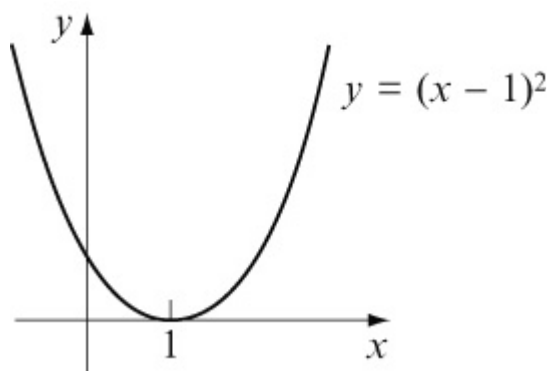

$$(b) f(x) = x - 3, g(x) = + \sqrt{x}$$

$$fg(x) = f(+ \sqrt{x}) = \sqrt{x} - 3$$

$$\text{Domain } x \geq 0$$

(It will not be defined for negative numbers)

$$\text{Range } fg(x) \geq -3$$

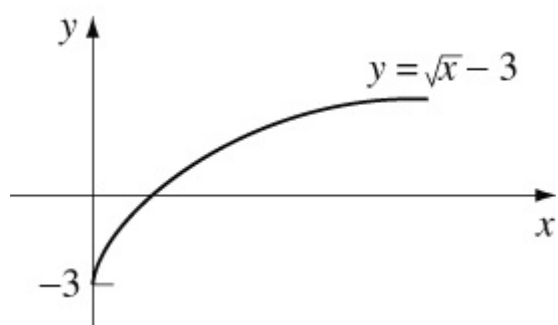

$$gf(x) = g(x - 3) = \sqrt{x - 3}$$

$$\text{Domain } x \geq 3$$

$$\text{Range } gf(x) \geq 0$$

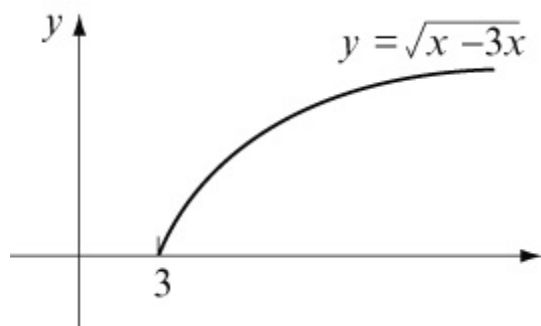

$$(c) f(x) = 2^x, g(x) = x + 3$$

$$fg(x) = f(x + 3) = 2^{x+3}$$

$$\text{Domain } x \in \mathbb{R}$$

$$\text{Range } fg(x) > 0$$

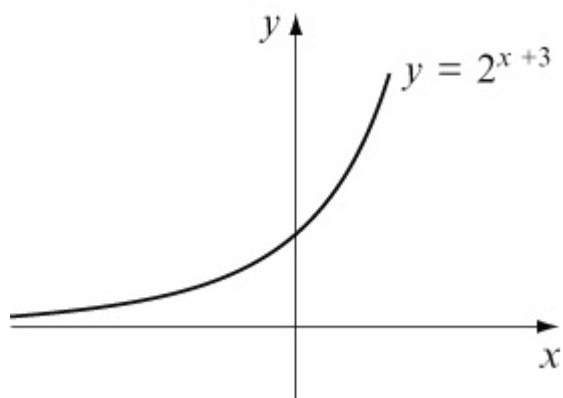

$$gf(x) = g(2^x) = 2^x + 3$$

Domain  $x \in \mathbb{R}$

Range  $gf(x) > 3$

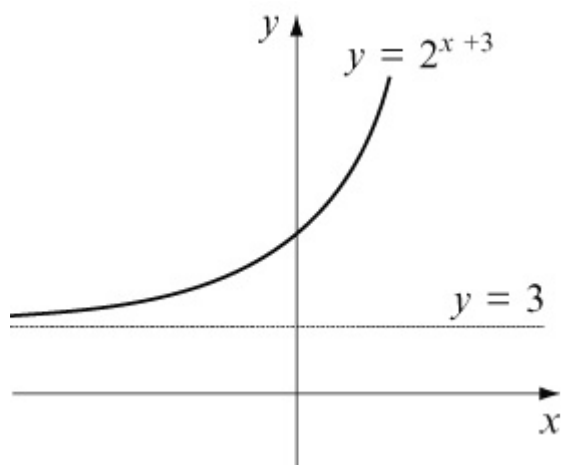

© Pearson Education Ltd 2008

# Solutionbank

## Edexcel AS and A Level Modular Mathematics

### Exercise D, Question 3

#### Question:

If  $f(x) = 3x - 2$  and  $g(x) = x^2$ , find the number(s)  $a$  such that  $fg(a) = gf(a)$ .

#### Solution:

$$f(x) = 3x - 2, g(x) = x^2$$

$$fg(x) = f(x^2) = 3x^2 - 2$$

$$gf(x) = g(3x - 2) = (3x - 2)^2$$

$$\text{If } fg(a) = gf(a)$$

$$3a^2 - 2 = (3a - 2)^2$$

$$3a^2 - 2 = 9a^2 - 12a + 4$$

$$0 = 6a^2 - 12a + 6$$

$$0 = a^2 - 2a + 1$$

$$0 = (a - 1)^2$$

$$\text{Hence } a = 1$$

# Solutionbank

## Edexcel AS and A Level Modular Mathematics

Exercise D, Question 4

### Question:

Given that  $s(x) = \frac{1}{x-2}$  and  $t(x) = 3x + 4$  find the number  $m$  such that  $ts(m) = 16$ .

### Solution:

$$s(x) = \frac{1}{x-2}, t(x) = 3x + 4$$

$$ts(x) = t\left(\frac{1}{x-2}\right) = 3 \times \left(\frac{1}{x-2}\right) + 4 = \frac{3}{x-2} + 4$$

If  $ts(m) = 16$

$$\frac{3}{m-2} + 4 = 16 \quad (-4)$$

$$\frac{3}{m-2} = 12 \quad [ \times (m-2) ]$$

$$3 = 12(m-2) \quad ( \div 12 )$$

$$\frac{3}{12} = m - 2$$

$$0.25 = m - 2$$

$$m = 2.25$$

© Pearson Education Ltd 2008

# Solutionbank

## Edexcel AS and A Level Modular Mathematics

### Exercise D, Question 5

#### Question:

The functions  $l(x)$ ,  $m(x)$ ,  $n(x)$  and  $p(x)$  are defined by  $l(x) = 2x + 1$ ,  $m(x) = x^2 - 1$ ,  $n(x) = \frac{1}{x+5}$  and  $p(x) = x^3$ . Find in terms of  $l$ ,  $m$ ,  $n$  and  $p$  the functions:

(a)  $4x + 3$

(b)  $4x^2 + 4x$

(c)  $\frac{1}{x^2 + 4}$

(d)  $\frac{2}{x+5} + 1$

(e)  $(x^2 - 1)^3$

(f)  $2x^2 - 1$

(g)  $x^{27}$

#### Solution:

(a)  $4x + 3 = 2(2x + 1) + 1 = 2l(x) + 1 = ll(x)$  [or  $l^2(x)$ ]

(b)  $4x^2 + 4x = (2x + 1)^2 - 1 = [l(x)]^2 - 1 = ml(x)$

(c)  $\frac{1}{x^2 + 4} = \frac{1}{(x^2 - 1) + 5} = \frac{1}{m(x) + 5} = nm(x)$

(d)  $\frac{2}{x+5} + 1 = 2 \times \frac{1}{x+5} + 1 = 2n(x) + 1 = ln(x)$

(e)  $(x^2 - 1)^3 = [m(x)]^3 = pm(x)$

(f)  $2x^2 - 1 = 2(x^2 - 1) + 1 = 2m(x) + 1 = lm(x)$

$$\begin{aligned} \text{(g) } x^{27} &= [ (x^3)^3 ]^3 = \{ [ p(x) ]^3 \}^3 = [ pp(x) ]^3 = ppp(x) \\ &= p^3(x) \end{aligned}$$

© Pearson Education Ltd 2008



# Solutionbank

## Edexcel AS and A Level Modular Mathematics

Exercise D, Question 6

### Question:

If  $m(x) = 2x + 3$  and  $n(x) = \frac{x-3}{2}$ , prove that  $mn(x) = x$ .

### Solution:

$$m(x) = 2x + 3, n(x) = \frac{x-3}{2}$$

$$mn(x) = m\left(\frac{x-3}{2}\right) = 2\left(\frac{x-3}{2}\right) + 3 = x - 3 + 3 = x$$

© Pearson Education Ltd 2008

# Solutionbank

## Edexcel AS and A Level Modular Mathematics

### Exercise D, Question 7

#### Question:

If  $s(x) = \frac{3}{x+1}$  and  $t(x) = \frac{3-x}{x}$ , prove that  $st(x) = x$ .

#### Solution:

$$s(x) = \frac{3}{x+1}, t(x) = \frac{3-x}{x}$$

$$\begin{aligned} st(x) &= s\left(\frac{3-x}{x}\right) \\ &= \frac{3}{\frac{3-x}{x}+1} \times x \\ &= \frac{3x}{3-x+x} \\ &= \frac{\cancel{3}x}{\cancel{3}} \\ &= x \end{aligned}$$

# Solutionbank

## Edexcel AS and A Level Modular Mathematics

Exercise D, Question 8

### Question:

If  $f(x) = \frac{1}{x+1}$ , prove that  $f^2(x) = \frac{x+1}{x+2}$ . Hence find an expression for  $f^3(x)$ .

### Solution:

$$f(x) = \frac{1}{x+1}$$

$$\begin{aligned} ff(x) &= f\left(\frac{1}{x+1}\right) \\ &= \frac{1}{\frac{1}{x+1}+1} \times (x+1) \\ &= \frac{x+1}{1+x+1} \\ &= \frac{x+1}{x+2} \end{aligned}$$

$$\begin{aligned} f^3(x) = f[f^2(x)] &= f\left(\frac{x+1}{x+2}\right) \\ &= \frac{1}{\frac{x+1}{x+2}+1} \times (x+2) \\ &= \frac{x+2}{x+1+x+2} \\ &= \frac{x+2}{2x+3} \end{aligned}$$

© Pearson Education Ltd 2008

# Solutionbank

## Edexcel AS and A Level Modular Mathematics

### Exercise E, Question 1

#### Question:

For the following functions  $f(x)$ , sketch the graphs of  $f(x)$  and  $f^{-1}(x)$  on the same set of axes. Determine also the equation of  $f^{-1}(x)$ .

(a)  $f(x) = 2x + 3 \quad \{x \in \mathbb{R}\}$

(b)  $f(x) = \frac{x}{2} \quad \left\{ \begin{array}{l} x \in \mathbb{R} \end{array} \right\}$

(c)  $f(x) = \frac{1}{x} \quad \left\{ \begin{array}{l} x \in \mathbb{R}, x \neq 0 \end{array} \right\}$

(d)  $f(x) = 4 - x \quad \{x \in \mathbb{R}\}$

(e)  $f(x) = x^2 + 2 \quad \{x \in \mathbb{R}, x \geq 0\}$

(f)  $f(x) = x^3 \quad \{x \in \mathbb{R}\}$

#### Solution:

(a) If  $y = 2x + 3$

$$y - 3 = 2x$$

$$\frac{y - 3}{2} = x$$

Hence  $f^{-1}(x) = \frac{x - 3}{2}$

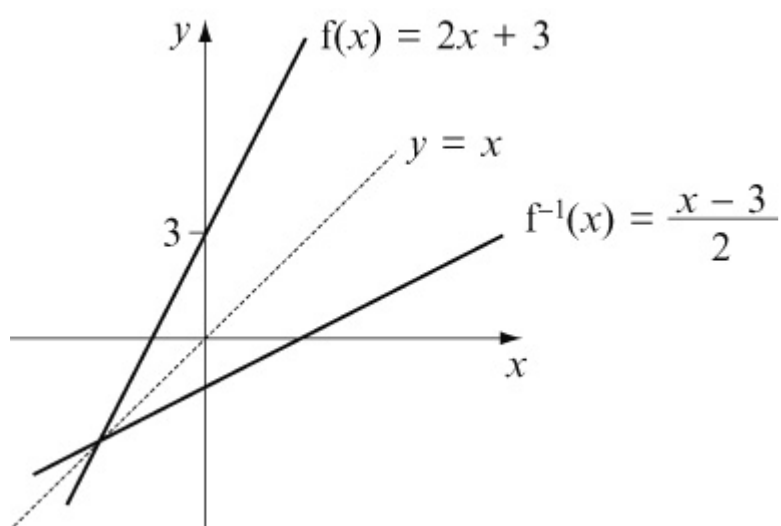

(b) If  $y = \frac{x}{2}$

$$2y = x$$

Hence  $f^{-1}(x) = 2x$

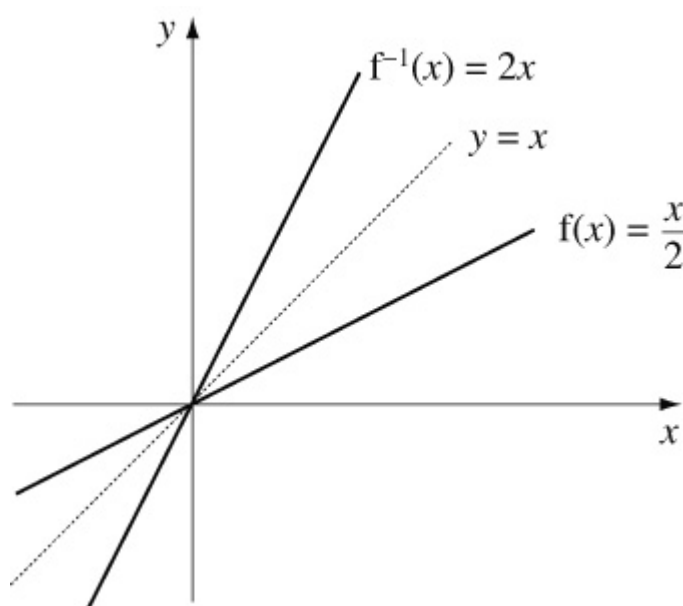

(c) If  $y = \frac{1}{x}$

$$yx = 1$$

$$x = \frac{1}{y}$$

Hence  $f^{-1}(x) = \frac{1}{x}$

Note that the inverse to the function is identical to the function.

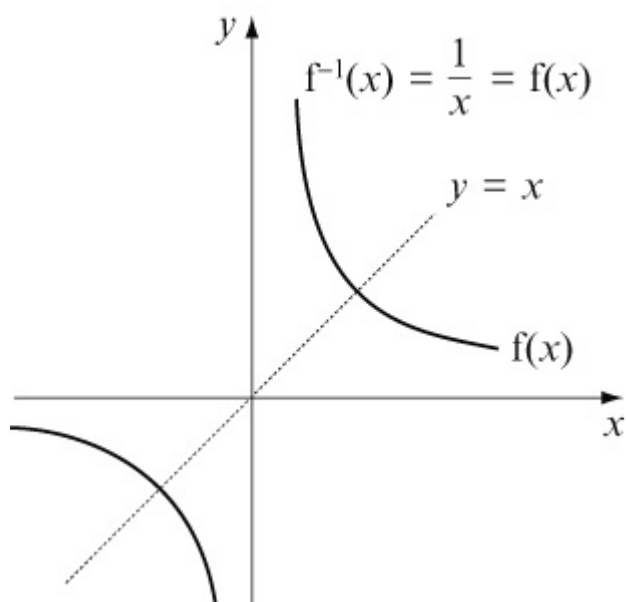

(d) If  $y = 4 - x$

$$x + y = 4$$

$$x = 4 - y$$

$$\text{Hence } f^{-1}(x) = 4 - x$$

Note that the inverse to the function is identical to the function.

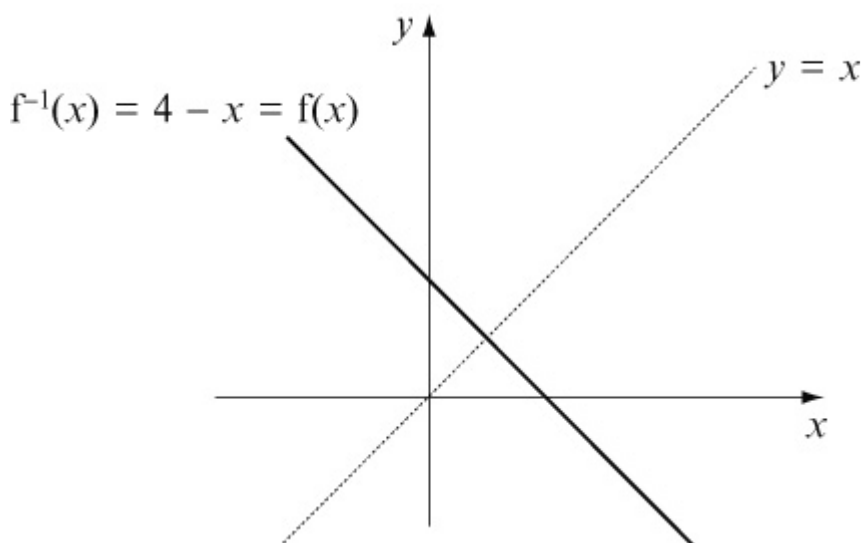

(e) If  $y = x^2 + 2$

$$y - 2 = x^2$$

$$\sqrt{y - 2} = x$$

$$\text{Hence } f^{-1}(x) = \sqrt{x - 2}$$

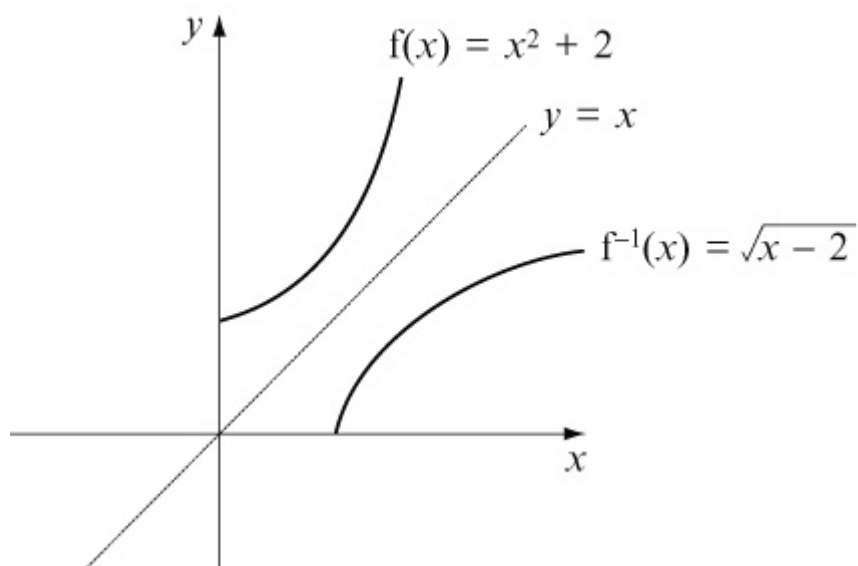

(f) If  $y = x^3$

$$\sqrt[3]{y} = x$$

$$\text{Hence } f^{-1}(x) = \sqrt[3]{x}$$

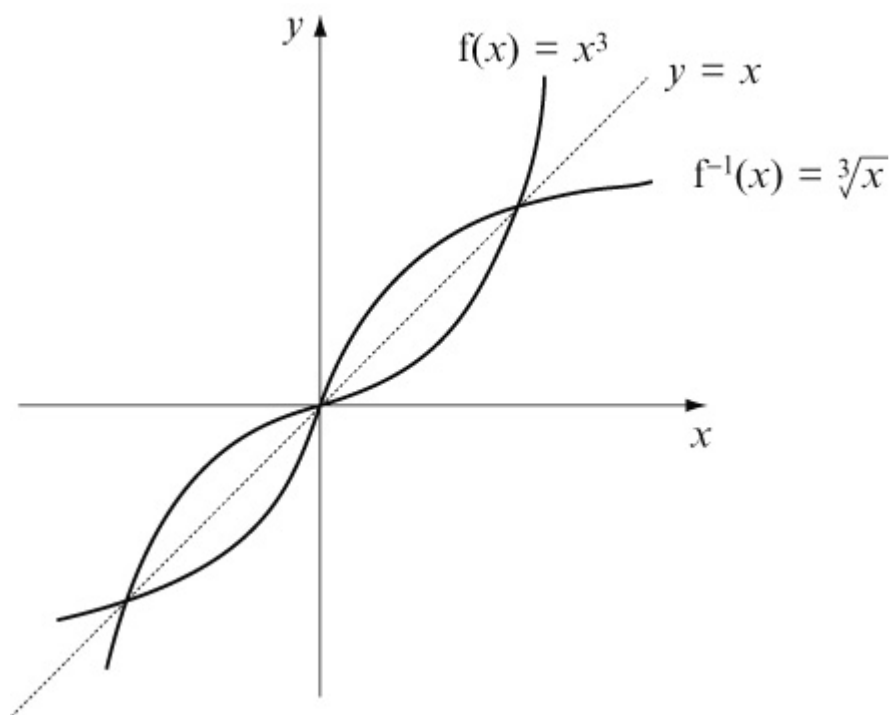

© Pearson Education Ltd 2008

# Solutionbank

## Edexcel AS and A Level Modular Mathematics

Exercise E, Question 2

### Question:

Determine which of the functions in Question 1 are self inverses. (That is to say the function and its inverse are identical.)

### Solution:

Look back at Question 1.

$$1(c) f(x) = \frac{1}{x} \text{ and}$$

$$1(d) f(x) = 4 - x$$

are both identical to their inverses.

© Pearson Education Ltd 2008



# Solutionbank

## Edexcel AS and A Level Modular Mathematics

### Exercise E, Question 3

#### Question:

Explain why the function  $g(x) = 4 - x$   $\{x \in \mathbb{R}, x > 0\}$  is not identical to its inverse.

#### Solution:

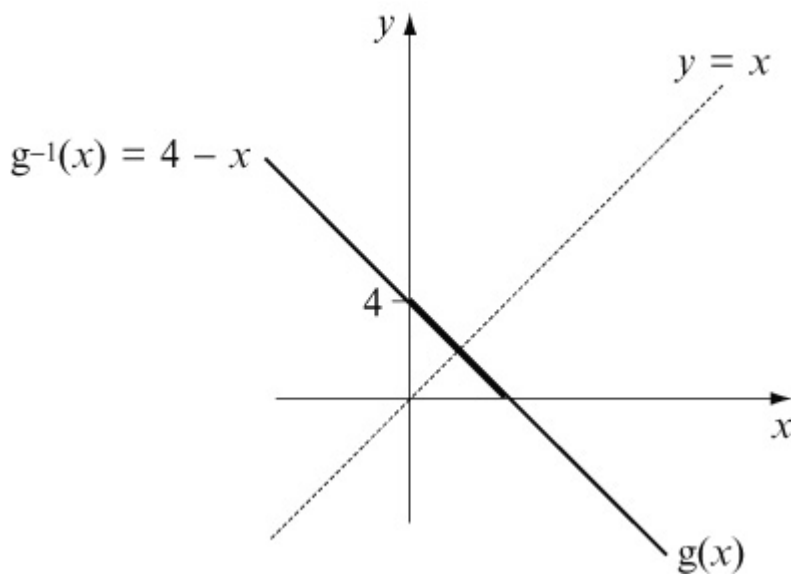

$$g(x) = 4 - x$$

has domain  $x > 0$

and range  $g(x) < 4$

$$\text{Hence } g^{-1}(x) = 4 - x$$

has domain  $x < 4$

and range  $g^{-1}(x) > 0$

Although  $g(x)$  and  $g^{-1}(x)$  have identical equations they act on different numbers and so are not identical. See graph.

# Solutionbank

## Edexcel AS and A Level Modular Mathematics

### Exercise E, Question 4

#### Question:

For the following functions  $g(x)$ , sketch the graphs of  $g(x)$  and  $g^{-1}(x)$  on the same set of axes. Determine the equation of  $g^{-1}(x)$ , taking care with its domain.

$$(a) \quad g(x) = \frac{1}{x} \quad \left\{ x \in \mathbb{R}, x \geq 3 \right\}$$

$$(b) \quad g(x) = 2x - 1 \quad \{ x \in \mathbb{R}, x \geq 0 \}$$

$$(c) \quad g(x) = \frac{3}{x-2} \quad \left\{ x \in \mathbb{R}, x > 2 \right\}$$

$$(d) \quad g(x) = \sqrt{x-3} \quad \{ x \in \mathbb{R}, x \geq 7 \}$$

$$(e) \quad g(x) = x^2 + 2 \quad \{ x \in \mathbb{R}, x > 4 \}$$

$$(f) \quad g(x) = x^3 - 8 \quad \{ x \in \mathbb{R}, x \leq 2 \}$$

#### Solution:

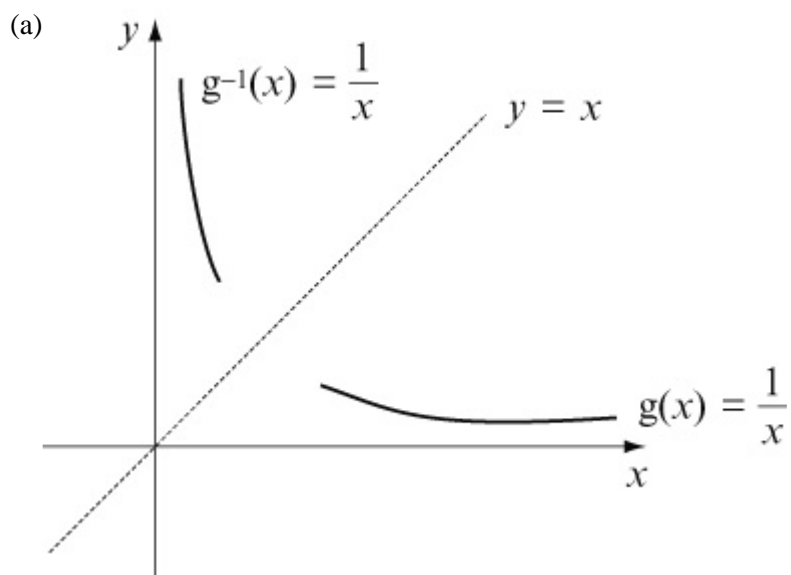

$$g(x) = \frac{1}{x} \left\{ x \in \mathbb{R}, x \geq 3 \right\}$$

has range  $g(x) \in \mathbb{R}, 0 < g(x) \leq \frac{1}{3}$

Changing the subject of the formula gives

$$g^{-1}(x) = \frac{1}{x} \left\{ x \in \mathbb{R}, 0 < x \leq \frac{1}{3} \right\}$$

(b)

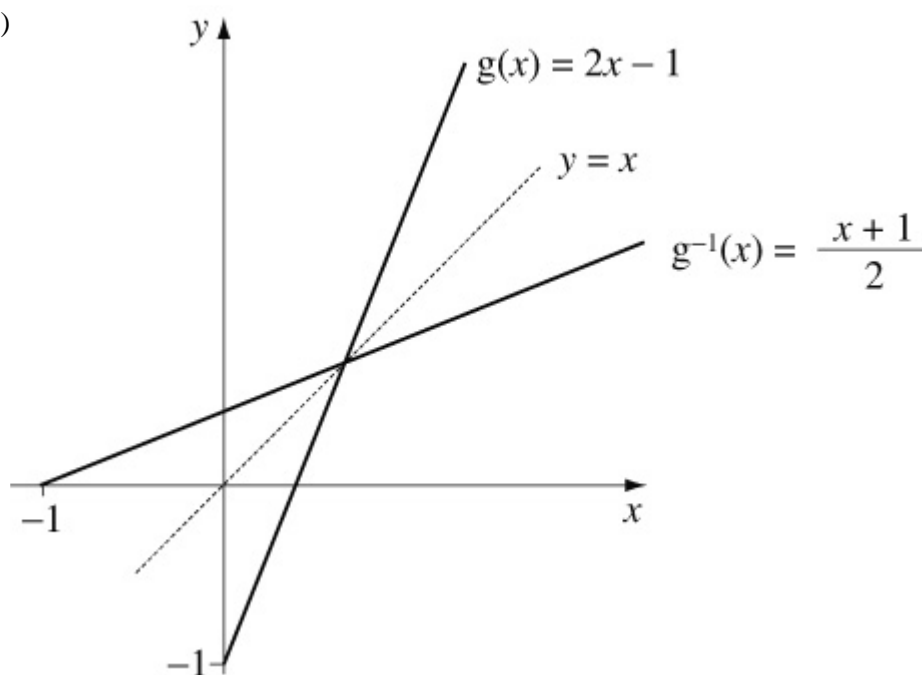

$$g(x) = 2x - 1 \left\{ x \in \mathbb{R}, x \geq 0 \right\}$$

has range  $g(x) \in \mathbb{R}, g(x) \geq -1$

Changing the subject of the formula gives

$$g^{-1}(x) = \frac{x+1}{2} \left\{ x \in \mathbb{R}, x \geq -1 \right\}$$

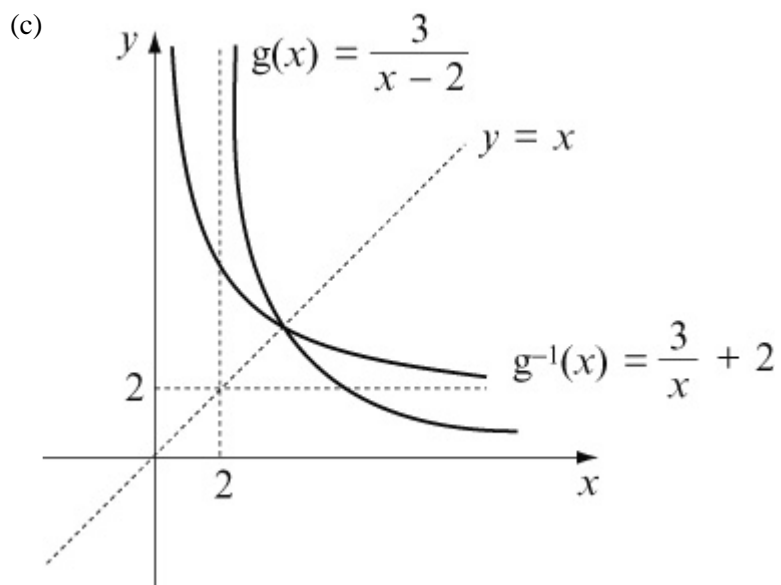

$$g(x) = \frac{3}{x-2} \quad \left\{ x \in \mathbb{R}, x > 2 \right\}$$

has range  $g(x) \in \mathbb{R}, g(x) > 0$

Changing the subject of the formula gives

$$y = \frac{3}{x-2}$$

$$y(x-2) = 3$$

$$x-2 = \frac{3}{y}$$

$$x = \frac{3}{y} + 2 \quad \left( \text{or } \frac{3+2y}{y} \right)$$

$$\text{Hence } g^{-1}(x) = \frac{3}{x} + 2 \quad \left( \text{or } \frac{3+2x}{x} \right)$$

$$\{ x \in \mathbb{R}, x > 0 \}$$

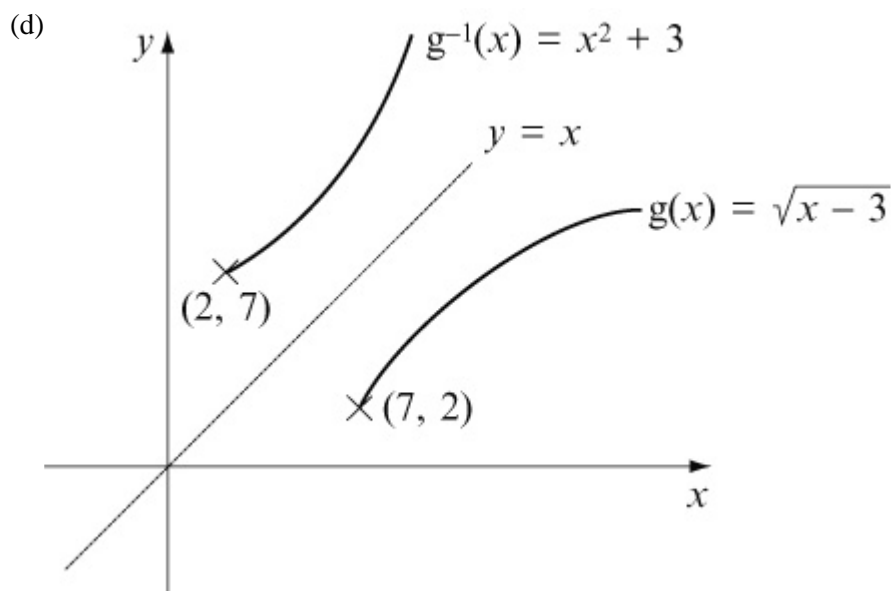

$$g(x) = \sqrt{x-3} \quad \{x \in \mathbb{R}, x \geq 7\}$$

has range  $g(x) \in \mathbb{R}, g(x) \geq 2$

Changing the subject of the formula gives

$$y = \sqrt{x-3}$$

$$y^2 = x-3$$

$$x = y^2 + 3$$

Hence  $g^{-1}(x) = x^2 + 3$  with domain  $x \in \mathbb{R}, x \geq 2$

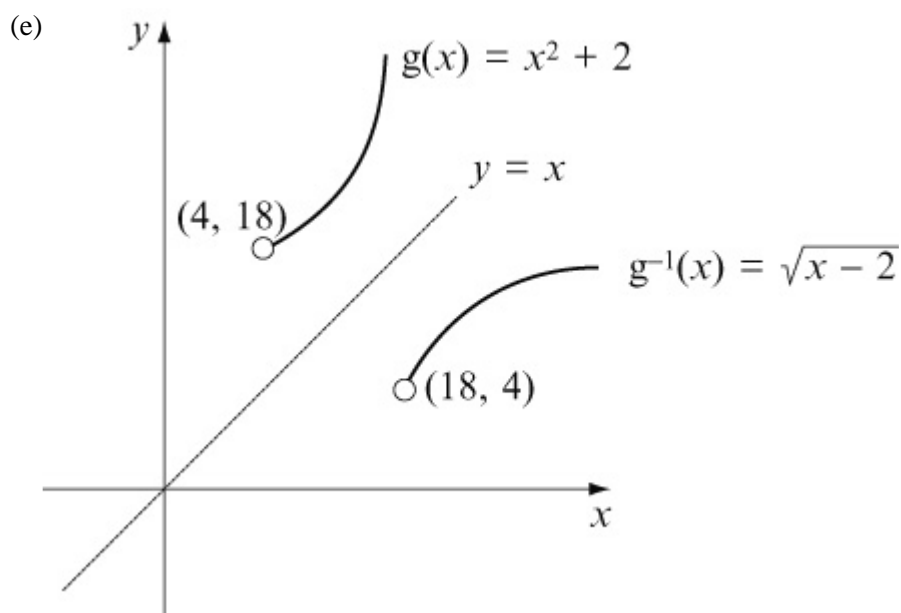

$$g(x) = x^2 + 2 \quad \{x \in \mathbb{R}, x > 4\}$$

has range  $g(x) \in \mathbb{R}, g(x) > 18$

Changing the subject of the formula gives

$$g^{-1}(x) = \sqrt{x-2} \quad \text{with domain } x \in \mathbb{R}, x > 18$$

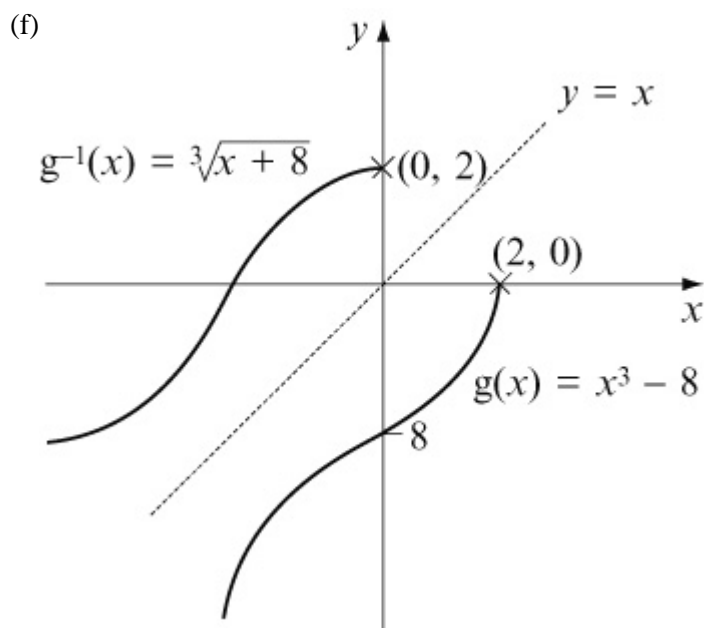

$$g(x) = x^3 - 8 \quad \{ x \in \mathbb{R}, x \leq 2 \}$$

has range  $g(x) \in \mathbb{R}, g(x) \leq 0$

Changing the subject of the formula gives

$$y = x^3 - 8$$

$$y + 8 = x^3$$

$$\sqrt[3]{y + 8} = x$$

Hence  $g^{-1}(x) = \sqrt[3]{x+8}$  with domain  $x \in \mathbb{R}, x \leq 0$

# Solutionbank

## Edexcel AS and A Level Modular Mathematics

Exercise E, Question 5

### Question:

The function  $m(x)$  is defined by  $m(x) = x^2 + 4x + 9$   $\{x \in \mathbb{R}, x > a\}$  for some constant  $a$ . If  $m^{-1}(x)$  exists, state the least value of  $a$  and hence determine the equation of  $m^{-1}(x)$ . State its domain.

### Solution:

$$m(x) = x^2 + 4x + 9 \quad \{x \in \mathbb{R}, x > a\}.$$

$$\text{Let } y = x^2 + 4x + 9$$

$$y = (x + 2)^2 - 4 + 9$$

$$y = (x + 2)^2 + 5$$

This has a minimum value of  $(-2, 5)$ .

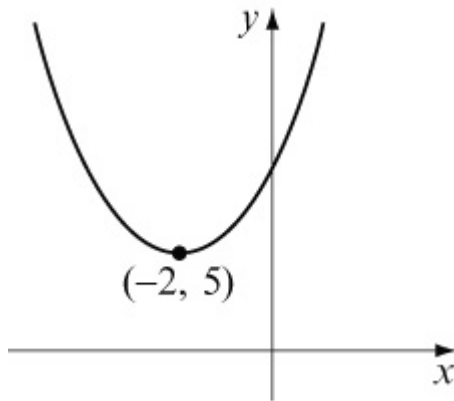

For  $m(x)$  to have an inverse it must be one-to-one.  
Hence the least value of  $a$  is  $-2$ .

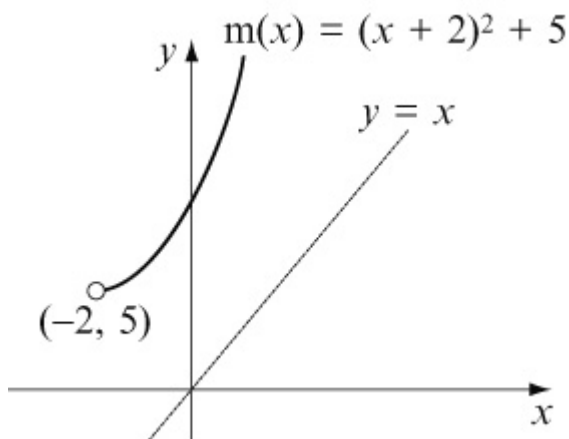

$m(x)$  would have a range of  $m(x) \in \mathbb{R}, m(x) > 5$

Changing the subject of the formula gives

$$y = (x + 2)^2 + 5$$

$$y - 5 = (x + 2)^2$$

$$\sqrt{y - 5} = x + 2$$

$$\sqrt{y - 5} - 2 = x$$

Hence  $m^{-1}(x) = \sqrt{x - 5} - 2$  with domain  $x \in \mathbb{R}, x > 5$



# Solutionbank

## Edexcel AS and A Level Modular Mathematics

Exercise E, Question 6

### Question:

Determine  $t^{-1}(x)$  if the function  $t(x)$  is defined by  $t(x) = x^2 - 6x + 5$   
 $\{x \in \mathbb{R}, x \geq 5\}$ .

### Solution:

$$t(x) = x^2 - 6x + 5 \quad \{x \in \mathbb{R}, x \geq 5\}$$

Let  $y = x^2 - 6x + 5$  (complete the square)

$$y = (x - 3)^2 - 9 + 5$$

$$y = (x - 3)^2 - 4$$

This has a minimum point at  $(3, -4)$ .

**Note.** Since  $x \geq 5$  is the domain,  $t(x)$  is a one-to-one function.

Change the subject of the formula to find  $t^{-1}(x)$  :

$$y = (x - 3)^2 - 4$$

$$y + 4 = (x - 3)^2$$

$$\sqrt{y + 4} = x - 3$$

$$\sqrt{y + 4} + 3 = x$$

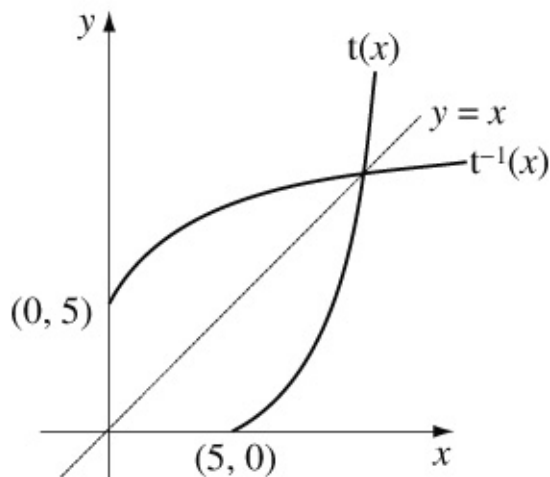

$$t(x) = x^2 - 6x + 5 \quad \{x \in \mathbb{R}, x \geq 5\}$$

has range  $t(x) \in \mathbb{R}, t(x) \geq 0$

So  $t^{-1}(x) = \sqrt{x + 4} + 3$  and has domain  $x \in \mathbb{R}, x \geq 0$

# Solutionbank

## Edexcel AS and A Level Modular Mathematics

### Exercise E, Question 7

#### Question:

The function  $h(x)$  is defined by  $h(x) = \frac{2x+1}{x-2} \left\{ x \in \mathbb{R}, x \neq 2 \right\}$ .

- (a) What happens to the function as  $x$  approaches 2?
- (b) Find  $h^{-1}(3)$ .
- (c) Find  $h^{-1}(x)$ , stating clearly its domain.
- (d) Find the elements of the domain that get mapped to themselves by the function.

#### Solution:

(a) As  $x \rightarrow 2$   $h(x) \rightarrow \frac{5}{0}$  and hence  $h(x) \rightarrow \infty$

(b) To find  $h^{-1}(3)$  we can find what element of the domain gets mapped to 3.

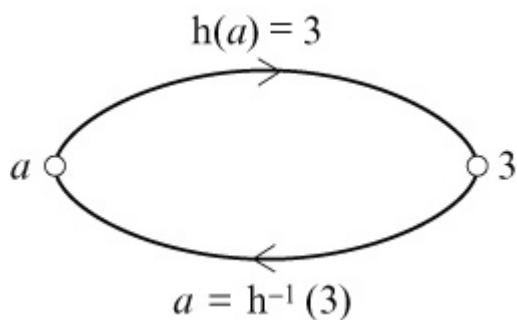

So  $h(a) = 3$

$$\frac{2a+1}{a-2} = 3$$

$$2a+1 = 3a-6$$

$$7 = a$$

So  $h^{-1}(3) = 7$

(c) Let  $y = \frac{2x+1}{x-2}$  and find  $x$  as a function of  $y$ .

$$y(x - 2) = 2x + 1$$

$$yx - 2y = 2x + 1$$

$$yx - 2x = 2y + 1$$

$$x(y - 2) = 2y + 1$$

$$x = \frac{2y + 1}{y - 2}$$

$$\text{So } h^{-1}(x) = \frac{2x + 1}{x - 2} \left\{ x \in \mathbb{R}, x \neq 2 \right\}$$

Hence the inverse function has exactly the same equation as the function. **But** the elements don't get mapped to themselves, see part (b).

(d) For elements to get mapped to themselves

$$h(b) = b$$

$$\frac{2b + 1}{b - 2} = b$$

$$2b + 1 = b(b - 2)$$

$$2b + 1 = b^2 - 2b$$

$$0 = b^2 - 4b - 1$$

$$b = \frac{4 \pm \sqrt{16 + 4}}{2} = \frac{4 \pm \sqrt{20}}{2} = \frac{4 \pm 2\sqrt{5}}{2} = 2 \pm \sqrt{5}$$

The elements  $2 + \sqrt{5}$  and  $2 - \sqrt{5}$  get mapped to themselves by the function.

# Solutionbank

## Edexcel AS and A Level Modular Mathematics

Exercise E, Question 8

### Question:

The function  $f(x)$  is defined by  $f(x) = 2x^2 - 3 \quad \{x \in \mathbb{R}, x < 0\}$ .  
Determine

- (a)  $f^{-1}(x)$  clearly stating its domain  
(b) the values of  $a$  for which  $f(a) = f^{-1}(a)$ .

### Solution:

(a) Let  $y = 2x^2 - 3$

$$y + 3 = 2x^2$$

$$\frac{y+3}{2} = x^2$$

$$\sqrt{\frac{y+3}{2}} = x$$

The domain of  $f^{-1}(x)$  is the range of  $f(x)$ .

$$f(x) = 2x^2 - 3 \quad \{x \in \mathbb{R}, x < 0\}$$

has range  $f(x) > -3$

Hence  $f^{-1}(x)$  **must** be the **negative** square root

$$f^{-1}(x) = -\sqrt{\frac{x+3}{2}} \text{ has domain } x \in \mathbb{R}, x > -3$$

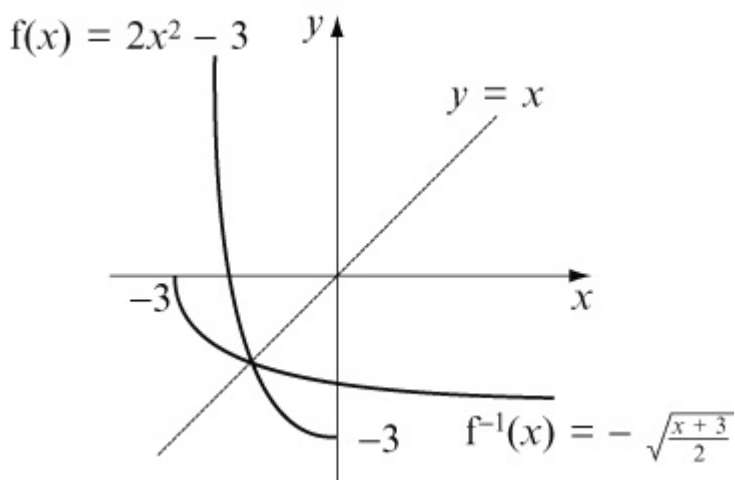

- (b) If  $f(a) = f^{-1}(a)$  then  $a$  is negative (see graph).  
Solve  $f(a) = a$

$$2a^2 - 3 = a$$

$$2a^2 - a - 3 = 0$$

$$(2a - 3)(a + 1) = 0$$

$$a = \frac{3}{2}, -1$$

Therefore  $a = -1$

© Pearson Education Ltd 2008

# Solutionbank

## Edexcel AS and A Level Modular Mathematics

### Exercise F, Question 1

#### Question:

Categorise the following as

- (i) not a function
- (ii) a one-to-one function
- (iii) a many-to-one function.

(a)

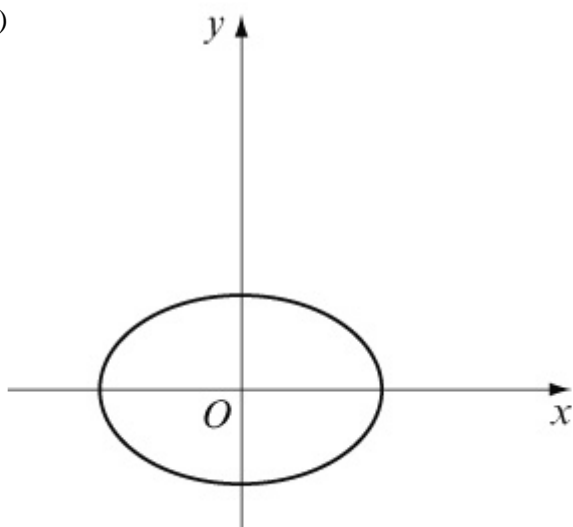

(b)

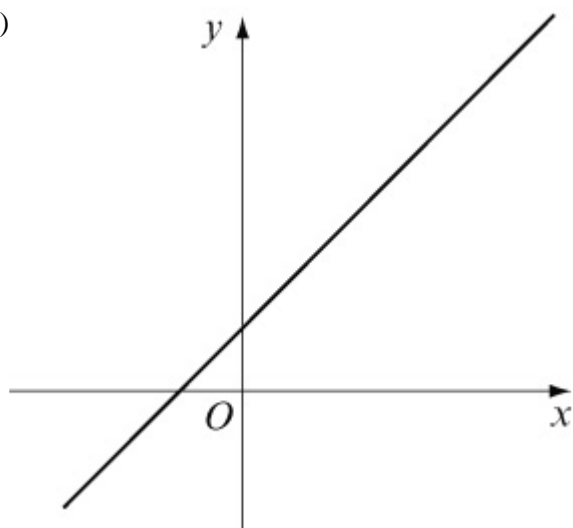

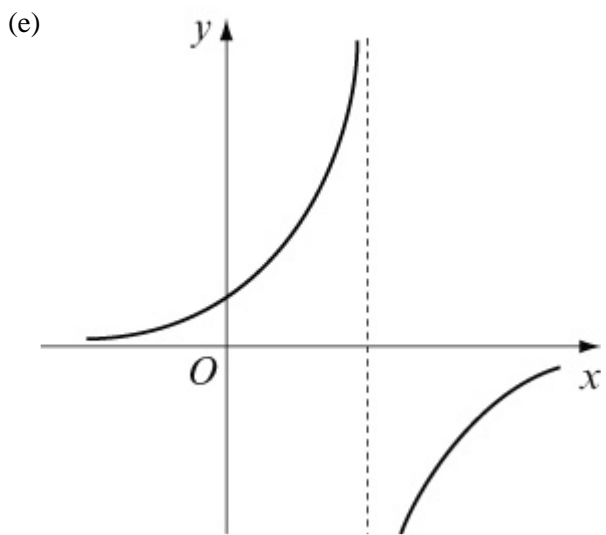
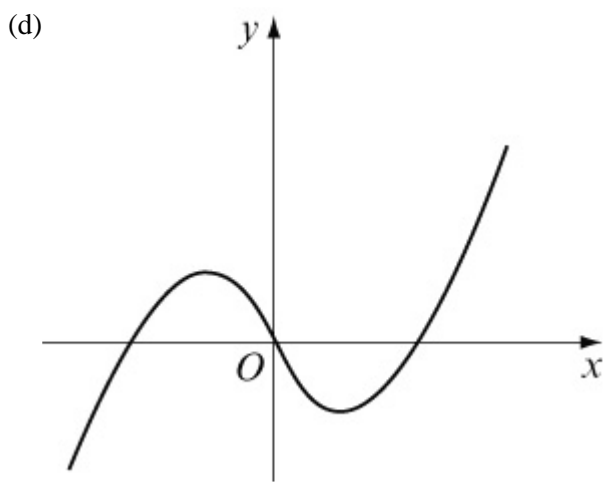
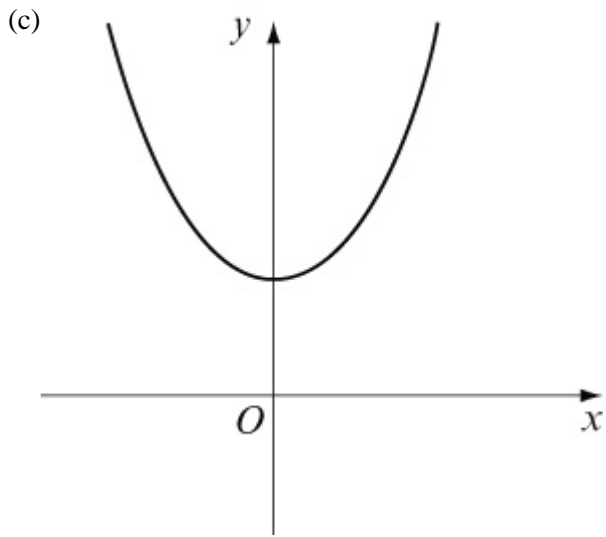

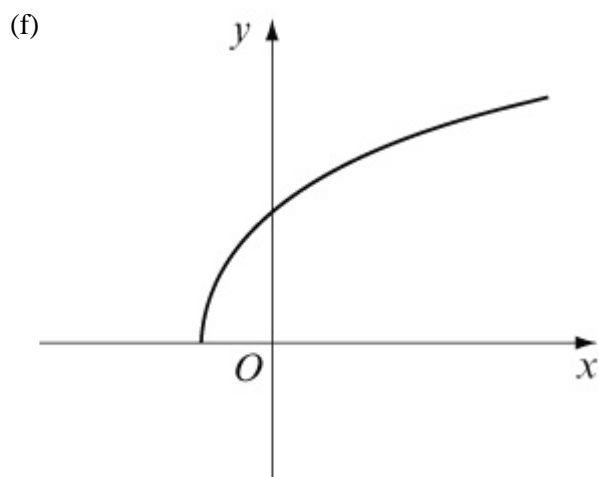

**Solution:**

(a) not a function

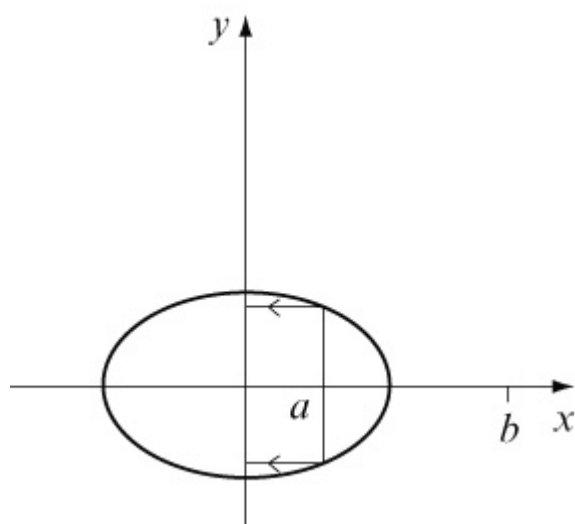

$x$  value  $a$  gets mapped to two values of  $y$ .  
 $x$  value  $b$  gets mapped to no values

(b) one-to-one function



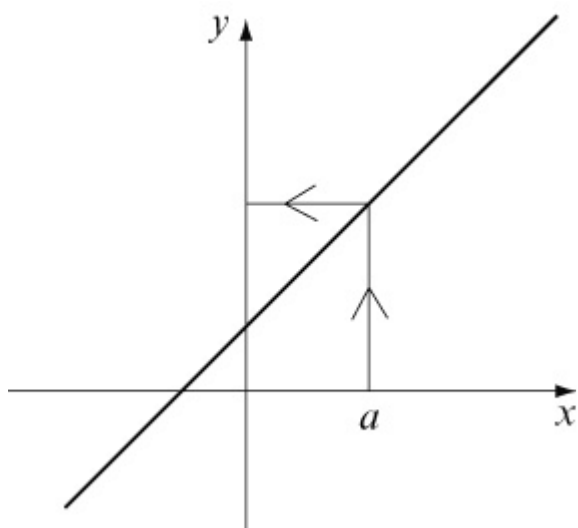

(c) many-to-one function

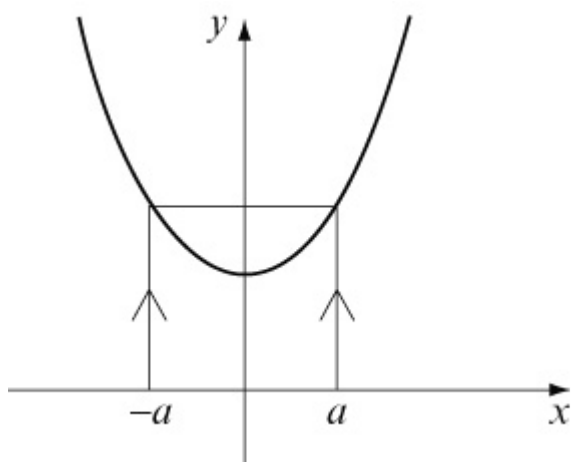

(d) many-to-one function

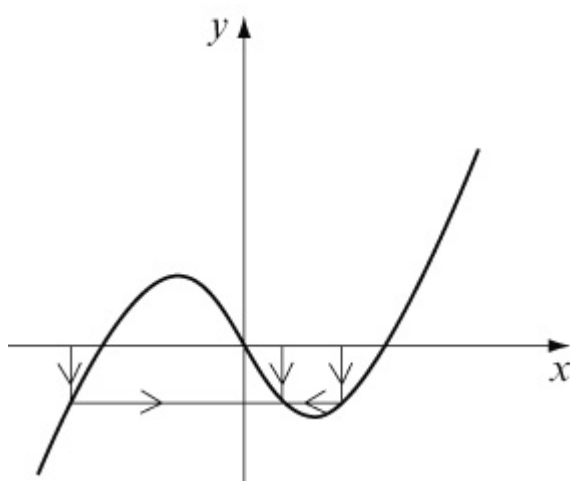

(e) not a function

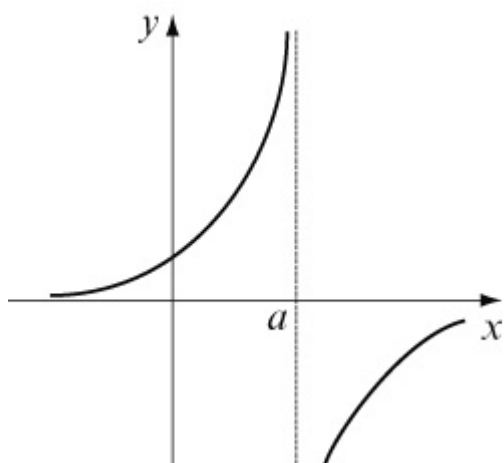

$x$  value  $a$  doesn't get mapped to any value of  $y$ .  
It could be redefined as a function if the domain is said to exclude point  $a$ .

(f) not a function

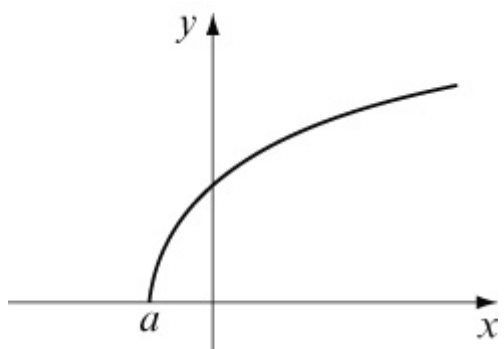

$x$  values less than  $a$  don't get mapped anywhere.  
Again we could define the domain to be  $x \geq a$  and then it would be a function.

# Solutionbank

## Edexcel AS and A Level Modular Mathematics

### Exercise F, Question 2

#### Question:

The following functions  $f(x)$ ,  $g(x)$  and  $h(x)$  are defined by

$$f(x) = 4(x - 2) \quad \{x \in \mathbb{R}, x \geq 0\}$$

$$g(x) = x^3 + 1 \quad \{x \in \mathbb{R}\}$$

$$h(x) = 3^x \quad \{x \in \mathbb{R}\}$$

- (a) Find  $f(7)$ ,  $g(3)$  and  $h(-2)$ .
- (b) Find the range of  $f(x)$  and the range of  $g(x)$ .
- (c) Find  $g^{-1}(x)$ .
- (d) Find the composite function  $fg(x)$ .
- (e) Solve  $gh(a) = 244$ .

#### Solution:

$$(a) f(7) = 4(7 - 2) = 4 \times 5 = 20$$

$$g(3) = 3^3 + 1 = 27 + 1 = 28$$

$$h(-2) = 3^{-2} = \frac{1}{3^2} = \frac{1}{9}$$

$$(b) f(x) = 4(x - 2) = 4x - 8$$

This is a straight line with gradient 4 and intercept  $-8$ .

The domain tells us that  $x \geq 0$ .

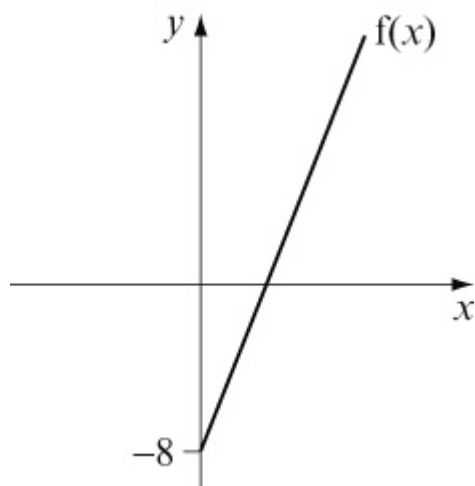

The range of  $f(x)$  is  $f(x) \in \mathbb{R}, f(x) \geq -8$

$$g(x) = x^3 + 1$$

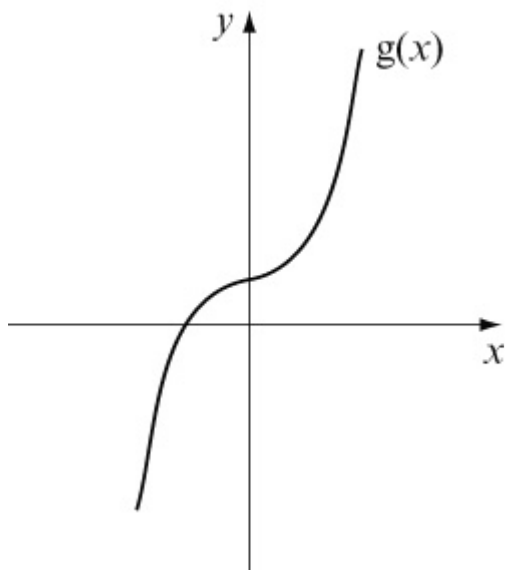

The range of  $g(x)$  is  $g(x) \in \mathbb{R}$

(c) Let  $y = x^3 + 1$  (change the subject of the formula)

$$y - 1 = x^3$$

$$\sqrt[3]{y - 1} = x$$

$$\text{Hence } g^{-1}(x) = \sqrt[3]{x - 1} \quad \{x \in \mathbb{R}\}$$

$$(d) fg(x) = f(x^3 + 1) = 4(x^3 + 1 - 2) = 4(x^3 - 1)$$

(e) Find  $gh(x)$  first.

$$gh(x) = g(3^x) = (3^x)^3 + 1 = 3^{3x} + 1$$

$$\text{If } gh(a) = 244$$

$$3^{3a} + 1 = 244$$

$$3^{3a} = 243$$

$$3^{3a} = 3^5$$

$$3a = 5$$

$$a = \frac{5}{3}$$

# Solutionbank

## Edexcel AS and A Level Modular Mathematics

### Exercise F, Question 3

#### Question:

The function  $n(x)$  is defined by

$$n(x) = \begin{cases} 5 - x & x \leq 0 \\ x^2 & x > 0 \end{cases}$$

- (a) Find  $n(-3)$  and  $n(3)$ .
- (b) Find the value(s) of  $a$  such that  $n(a) = 50$ .

#### Solution:

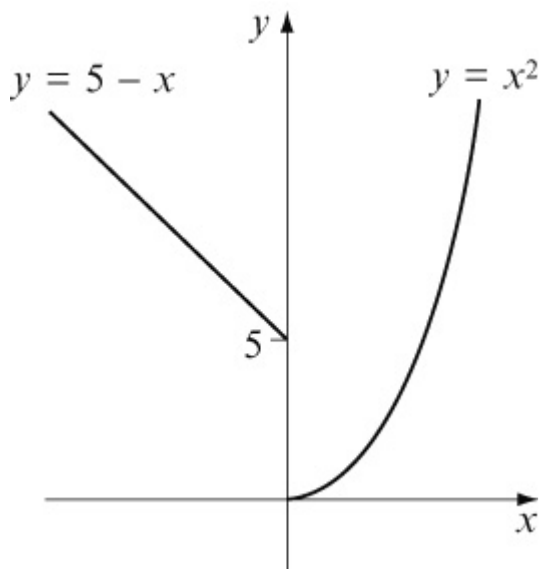

$y = 5 - x$  is a straight line with gradient  $-1$  passing through  $5$  on the  $y$  axis.

$y = x^2$  is a  $\cup$ -shaped quadratic passing through  $(0, 0)$ .

$$(a) \quad n(-3) = 5 - (-3) = 5 + 3 = 8$$

$$n(3) = 3^2 = 9$$

- (b) There are two values of  $a$ .

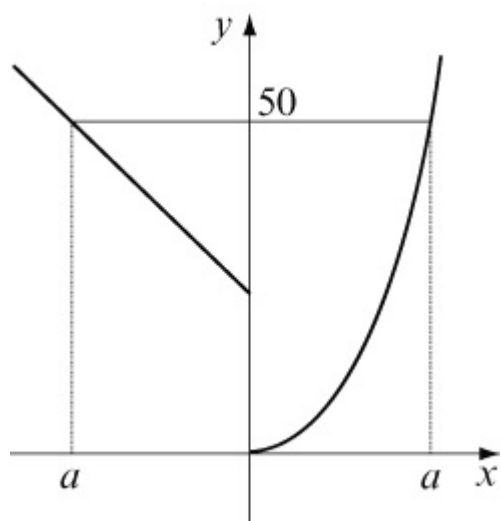

The negative value of  $a$  is where

$$5 - a = 50$$

$$a = 5 - 50$$

$$a = -45$$

The positive value of  $a$  is where

$$a^2 = 50$$

$$a = \sqrt{50}$$

$$a = 5\sqrt{2}$$

The values of  $a$  such that  $n(a) = 50$  are  $-45$  and  $+5\sqrt{2}$ .

# Solutionbank

## Edexcel AS and A Level Modular Mathematics

### Exercise F, Question 4

#### Question:

The function  $g(x)$  is defined as  $g(x) = 2x + 7$   $\{x \in \mathbb{R}, x \geq 0\}$ .

- (a) Sketch  $g(x)$  and find the range.
- (b) Determine  $g^{-1}(x)$ , stating its domain.
- (c) Sketch  $g^{-1}(x)$  on the same axes as  $g(x)$ , stating the relationship between the two graphs.

#### Solution:

- (a)  $y = 2x + 7$  is a straight line of gradient 2 passing through 7 on the y axis. The domain is given as  $x \geq 0$ .

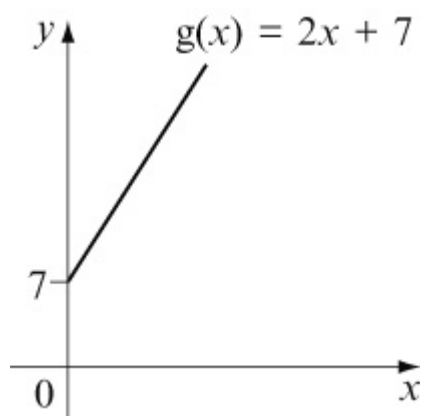

Hence the range is  $g(x) \geq 7$

- (b) The domain of the inverse function is  $x \geq 7$ . To find the equation of the inverse function use a flow chart.

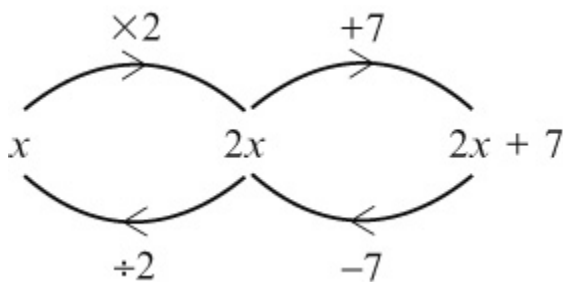

$$g^{-1}(x) = \frac{x-7}{2} \text{ and has domain } x \geq 7$$

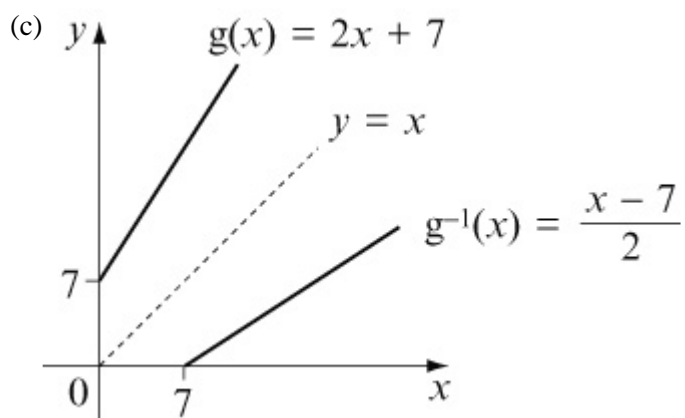

$g^{-1}(x)$  is the reflection of  $g(x)$  in the line  $y = x$ .

© Pearson Education Ltd 2008



# Solutionbank

## Edexcel AS and A Level Modular Mathematics

### Exercise F, Question 5

#### Question:

The functions  $f$  and  $g$  are defined by

$$f : x \rightarrow 4x - 1 \quad \{ x \in \mathbb{R} \}$$

$$g : x \rightarrow \frac{3}{2x-1} \quad \left\{ x \in \mathbb{R}, x \neq \frac{1}{2} \right\}$$

Find in its simplest form:

- the inverse function  $f^{-1}$
- the composite function  $gf$ , stating its domain
- the values of  $x$  for which  $2f(x) = g(x)$ , giving your answers to 3 decimal places.

[E]

#### Solution:

$$(a) f : x \rightarrow 4x - 1$$

Let  $y = 4x - 1$  and change the subject of the formula.

$$\Rightarrow y + 1 = 4x$$

$$\Rightarrow x = \frac{y+1}{4}$$

$$\text{Hence } f^{-1} : x \rightarrow \frac{x+1}{4}$$

$$(b) gf(x) = g(4x-1) = \frac{3}{2(4x-1)-1} = \frac{3}{8x-3}$$

$$\text{Hence } gf : x \rightarrow \frac{3}{8x-3}$$

The domain would include all the real numbers apart from  $x = \frac{3}{8}$  (i.e. where  $8x - 3 = 0$ ).

$$(c) \text{ If } 2f(x) = g(x)$$

$$2 \times (4x - 1) = \frac{3}{2x-1}$$

$$8x - 2 = \frac{3}{2x - 1}$$

$$(8x - 2)(2x - 1) = 3$$

$$16x^2 - 12x + 2 = 3$$

$$16x^2 - 12x - 1 = 0$$

$$\text{Use } x = \frac{-b \pm \sqrt{b^2 - 4ac}}{2a} \text{ with } a = 16, b = -12 \text{ and } c = -1.$$

$$\text{Then } x = \frac{12 \pm \sqrt{144 + 64}}{32} = \frac{12 \pm \sqrt{208}}{32} = 0.826, -0.076$$

Values of  $x$  are  $-0.076$  and  $0.826$

© Pearson Education Ltd 2008

# Solutionbank

## Edexcel AS and A Level Modular Mathematics

### Exercise F, Question 6

#### Question:

The function  $f(x)$  is defined by

$$f(x) = \begin{cases} -x & x \leq 1 \\ x - 2 & x > 1 \end{cases}$$

(a) Sketch the graph of  $f(x)$  for  $-2 \leq x \leq 6$ .

(b) Find the values of  $x$  for which  $f(x) = -\frac{1}{2}$ .

[E]

#### Solution:

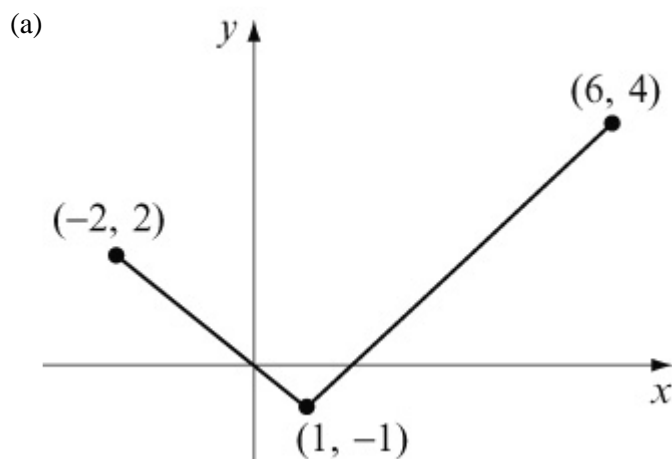

For  $x \leq 1$ ,  $f(x) = -x$

This is a straight line of gradient  $-1$ .

At point  $x = 1$ , its  $y$  coordinate is  $-1$ .

For  $x > 1$ ,  $f(x) = x - 2$

This is a straight line of gradient  $+1$ .

At point  $x = 1$ , its  $y$  coordinate is also  $-1$ .

The graph is said to be **continuous**.

(b) There are two values at which  $f(x) = -\frac{1}{2}$  (see graph).

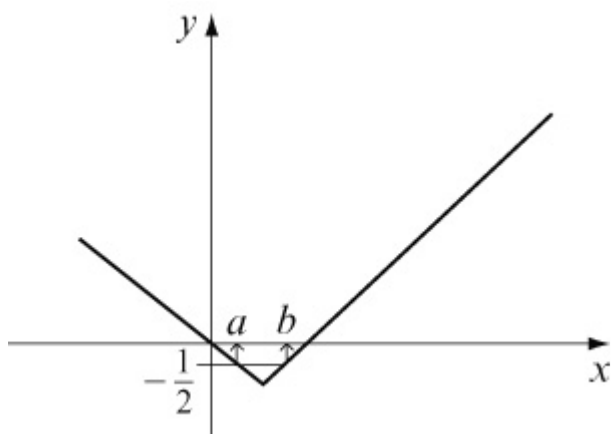

Point  $a$  is where

$$-x = -\frac{1}{2} \Rightarrow x = \frac{1}{2}$$

Point  $b$  is where

$$x - 2 = -\frac{1}{2} \Rightarrow x = 1\frac{1}{2}$$

The values of  $x$  for which  $f(x) = -\frac{1}{2}$  are  $\frac{1}{2}$  and  $1\frac{1}{2}$ .

# Solutionbank

## Edexcel AS and A Level Modular Mathematics

### Exercise F, Question 7

#### Question:

The function  $f$  is defined by

$$f : x \rightarrow \frac{2x+3}{x-1} \quad \left\{ \begin{array}{l} x \in \mathbb{R}, \\ x > 1 \end{array} \right\}$$

(a) Find  $f^{-1}(x)$ .

(b) Find (i) the range of  $f^{-1}(x)$

(ii) the domain of  $f^{-1}(x)$ .

[E]

#### Solution:

(a) To find  $f^{-1}(x)$  change the subject of the formula.

$$\text{Let } y = \frac{2x+3}{x-1}$$

$$y(x-1) = 2x+3$$

$$yx - y = 2x + 3$$

$$yx - 2x = y + 3$$

$$x(y-2) = y+3$$

$$x = \frac{y+3}{y-2}$$

$$\text{Therefore } f^{-1} : x \rightarrow \frac{x+3}{x-2}$$

(b)  $f(x)$  has domain  $\{x \in \mathbb{R}, x > 1\}$  and range  $\{f(x) \in \mathbb{R}, f(x) > 2\}$

$$\text{As } x \rightarrow \infty, y \rightarrow \frac{2x}{x} = 2$$

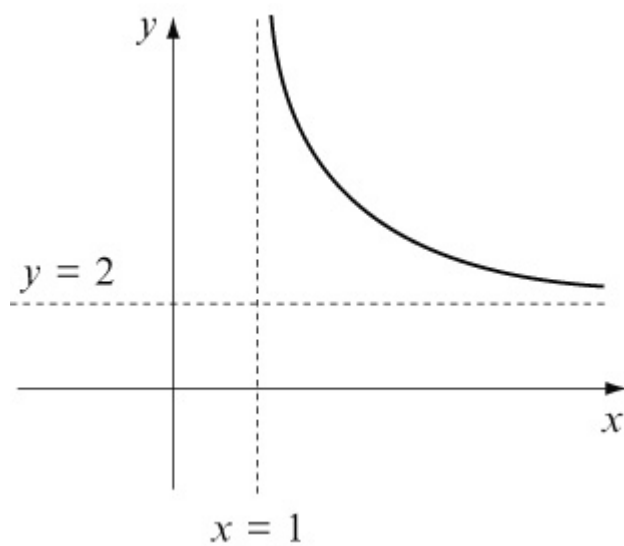

So  $f^{-1}(x)$  has domain  $\{x \in \mathbb{R}, x > 2\}$  and range  $\{f^{-1}(x) \in \mathbb{R}, f^{-1}(x) > 1\}$

# Solutionbank

## Edexcel AS and A Level Modular Mathematics

### Exercise F, Question 8

#### Question:

The functions  $f$  and  $g$  are defined by

$$f : x \rightarrow \frac{x}{x-2} \quad \left\{ \begin{array}{l} x \in \mathbb{R}, \\ x \neq 2 \end{array} \right\}$$

$$g : x \rightarrow \frac{3}{x} \quad \left\{ \begin{array}{l} x \in \mathbb{R}, \\ x \neq 0 \end{array} \right\}$$

- (a) Find an expression for  $f^{-1}(x)$ .
- (b) Write down the range of  $f^{-1}(x)$ .
- (c) Calculate  $gf(1.5)$ .
- (d) Use algebra to find the values of  $x$  for which  $g(x) = f(x) + 4$ .

[E]

#### Solution:

- (a) To find  $f^{-1}(x)$  change the subject of the formula.

$$\text{Let } y = \frac{x}{x-2}$$

$$y(x-2) = x$$

$$yx - 2y = x \quad (\text{rearrange})$$

$$yx - x = 2y$$

$$x(y-1) = 2y$$

$$x = \frac{2y}{y-1}$$

It must always be rewritten as a function in  $x$ :

$$f^{-1}\left(x\right) = \frac{2x}{x-1}$$

- (b) The range of  $f^{-1}(x)$  is the domain of  $f(x)$ .
- Hence range is  $\{f^{-1}(x) \in \mathbb{R}, f^{-1}(x) \neq 2\}$ .

$$(c) \quad g\left(\frac{1.5}{1.5-2}\right) = g\left(\frac{1.5}{-0.5}\right) = g(-3) = \frac{3}{-3} = -1$$

$$(d) \quad \text{If } g(x) = f(x) + 4$$

$$\frac{3}{x} = \frac{x}{x-2} + 4 \quad \left[ \times x(x-2) \right]$$

$$3(x-2) = x \times x + 4x(x-2)$$

$$3x - 6 = x^2 + 4x^2 - 8x$$

$$0 = 5x^2 - 11x + 6$$

$$0 = (5x - 6)(x - 1)$$

$$\Rightarrow x = \frac{6}{5}, 1$$

The values of  $x$  for which  $g(x) = f(x) + 4$  are  $\frac{6}{5}$  and 1.



# Solutionbank

## Edexcel AS and A Level Modular Mathematics

### Exercise F, Question 9

#### Question:

The functions  $f$  and  $g$  are given by

$$f : x \rightarrow \frac{x}{x^2 - 1} - \frac{1}{x + 1} \quad \left\{ x \in \mathbb{R}, x > 1 \right\}$$

$$g : x \rightarrow \frac{2}{x} \quad \left\{ x \in \mathbb{R}, x > 0 \right\}$$

(a) Show that  $f(x) = \frac{1}{(x-1)(x+1)}$ .

(b) Find the range of  $f(x)$ .

(c) Solve  $gf(x) = 70$ .

[E]

#### Solution:

$$\begin{aligned} \text{(a) } f(x) &= \frac{x}{x^2 - 1} - \frac{1}{x + 1} \\ &= \frac{x}{(x + 1)(x - 1)} - \frac{1}{(x + 1)} \\ &= \frac{x}{(x + 1)(x - 1)} - \frac{x - 1}{(x + 1)(x - 1)} \\ &= \frac{x - (x - 1)}{(x + 1)(x - 1)} \\ &= \frac{1}{(x + 1)(x - 1)} \end{aligned}$$

(b) The range of  $f(x)$  is the set of values that  $y$  take.

By using a graphical calculator we can see that  $y = f(x)$  is

$x \in \mathbb{R}, x \neq -1, x \neq 1$  is a symmetrical graph about the  $y$  axis.

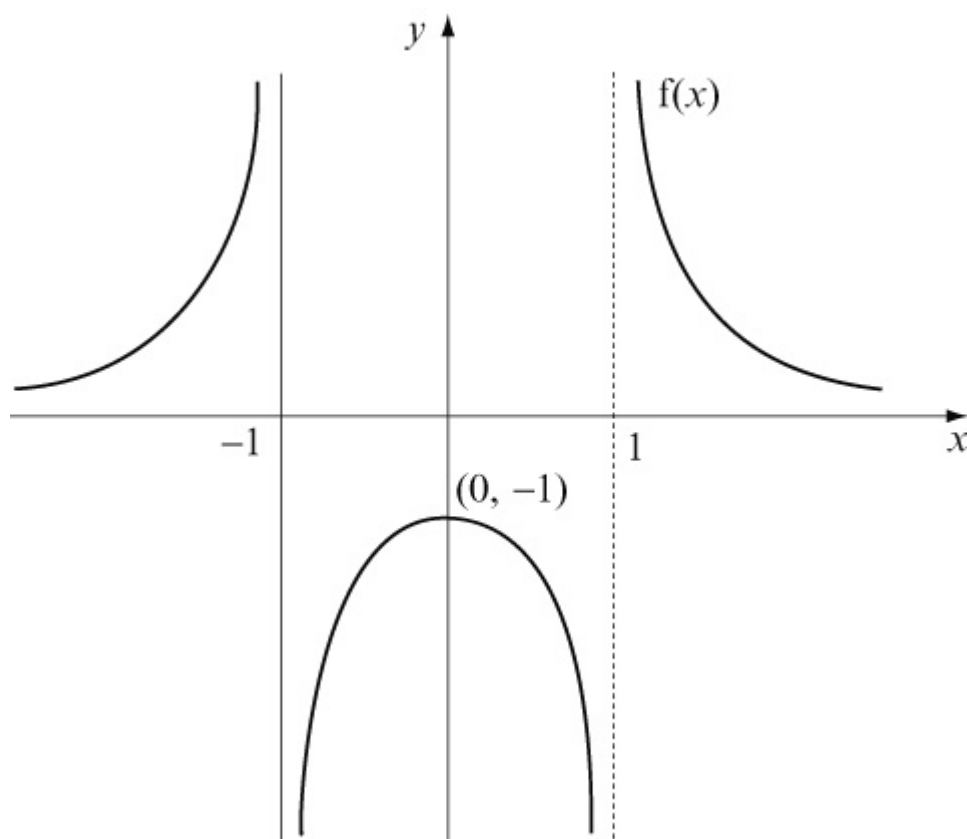

For  $x > 1$ ,  $f(x) > 0$

$$(c) \quad gf(x) = g \left[ \frac{1}{(x-1)(x+1)} \right] = \frac{2}{\frac{1}{(x-1)(x+1)}} = 2 \times$$

$$\frac{(x-1)(x+1)}{1} = 2 \left( \begin{array}{c} \\ x-1 \\ \end{array} \right) \left( \begin{array}{c} \\ x+1 \\ \end{array} \right)$$

$$\text{If } gf(x) = 70$$

$$2(x-1)(x+1) = 70$$

$$(x-1)(x+1) = 35$$

$$x^2 - 1 = 35$$

$$x^2 = 36$$

$$x = \pm 6$$

# Solutionbank

## Edexcel AS and A Level Modular Mathematics

### Exercise A, Question 1

#### Question:

Sketch the graphs of

(a)  $y = e^x + 1$

(b)  $y = 4e^{-2x}$

(c)  $y = 2e^x - 3$

(d)  $y = 4 - e^x$

(e)  $y = 6 + 10e^{\frac{1}{2}x}$

(f)  $y = 100e^{-x} + 10$

#### Solution:

(a)  $y = e^x + 1$

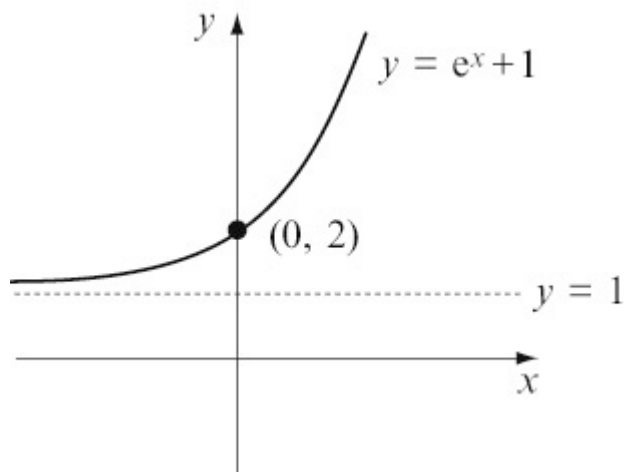

This is the normal  $y = e^x$  'moved up' (translated) 1 unit.

(b)  $y = 4e^{-2x}$

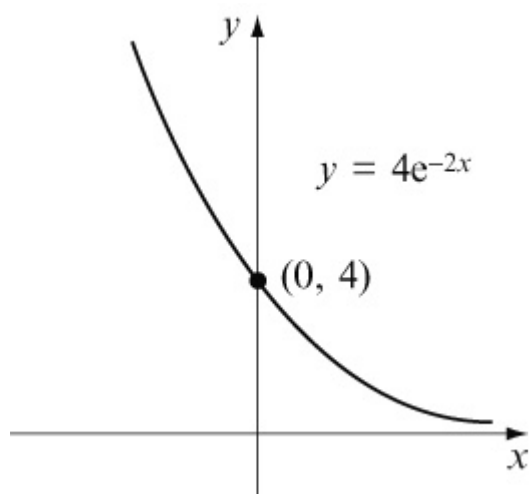

$$x = 0 \Rightarrow y = 4$$

$$\text{As } x \rightarrow -\infty, y \rightarrow \infty$$

$$\text{As } x \rightarrow \infty, y \rightarrow 0$$

This is an exponential decay type graph.

$$(c) y = 2e^x - 3$$

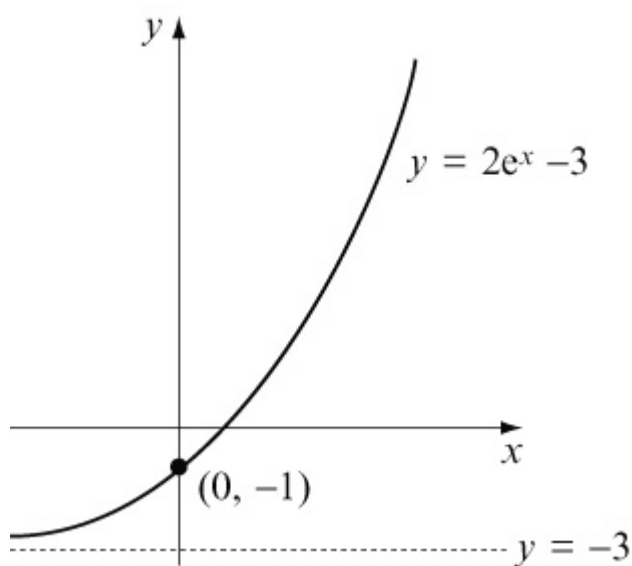

$$x = 0 \Rightarrow y = 2 \times 1 - 3 = -1$$

$$\text{As } x \rightarrow \infty, y \rightarrow \infty$$

$$\text{As } x \rightarrow -\infty, y \rightarrow 2 \times 0 - 3 = -3$$

$$(d) y = 4 - e^x$$

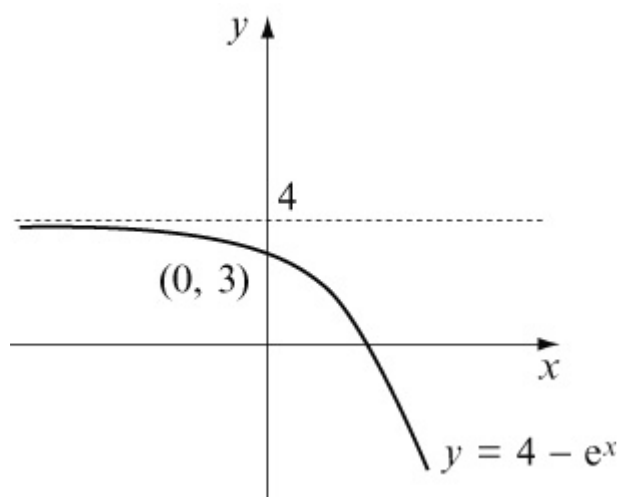

$$x = 0 \Rightarrow y = 4 - 1 = 3$$

As  $x \rightarrow \infty$ ,  $y \rightarrow 4 - \infty$ , i.e.  $y \rightarrow -\infty$

As  $x \rightarrow -\infty$ ,  $y \rightarrow 4 - 0 = 4$

(e)  $y = 6 + 10 \frac{1}{2}^x$

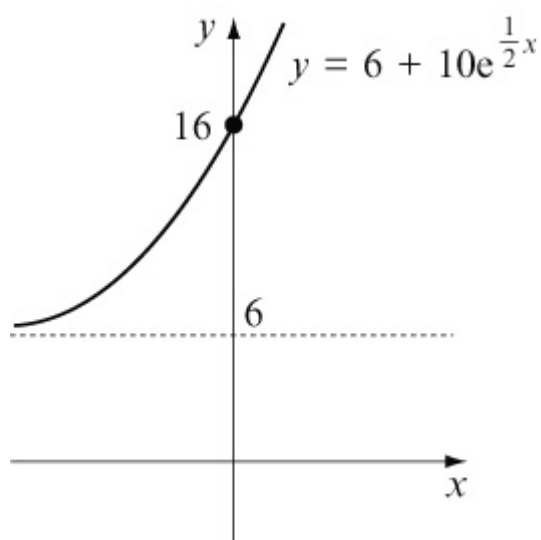

$$x = 0 \Rightarrow y = 6 + 10 \times 1 = 16$$

As  $x \rightarrow \infty$ ,  $y \rightarrow \infty$

As  $x \rightarrow -\infty$ ,  $y \rightarrow 6 + 10 \times 0 = 6$

(f)  $y = 100e^{-x} + 10$

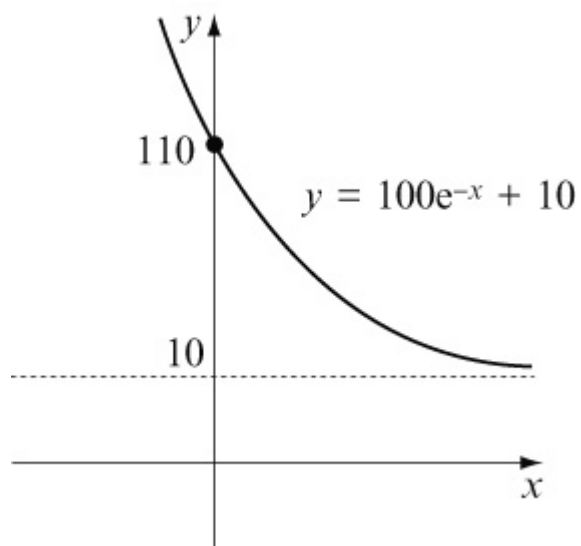

$$x = 0 \Rightarrow y = 100 \times 1 + 10 = 110$$

$$\text{As } x \rightarrow \infty, y \rightarrow 100 \times 0 + 10 = 10$$

$$\text{As } x \rightarrow -\infty, y \rightarrow \infty$$

© Pearson Education Ltd 2008

# Solutionbank

## Edexcel AS and A Level Modular Mathematics

### Exercise A, Question 2

#### Question:

The value of a car varies according to the formula

$$V = 20\,000e^{-\frac{t}{12}}$$

where  $V$  is the value in £'s and  $t$  is its age in years from new.

- State its value when new.
- Find its value (to the nearest £) after 4 years.
- Sketch the graph of  $V$  against  $t$ .

#### Solution:

$$V = 20\,000e^{-\frac{t}{12}}$$

- (a) The new value is when  $t = 0$ .

$$\Rightarrow V = 20\,000 \times e^{-\frac{0}{12}} = 20\,000 \times 1 = 20\,000$$

New value = £20 000

- (b) Value after 4 years is given when  $t = 4$ .

$$\Rightarrow V = 20\,000 \times e^{-\frac{4}{12}} = 20\,000 \times e^{-\frac{1}{3}} = 14\,330.63$$

Value after 4 years is £14 331 (to nearest £)

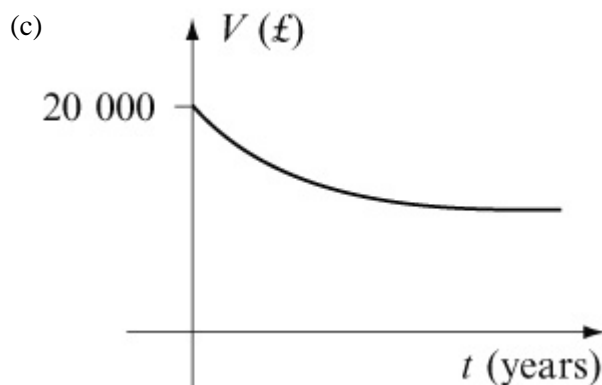

# Solutionbank

## Edexcel AS and A Level Modular Mathematics

### Exercise A, Question 3

#### Question:

The population of a country is increasing according to the formula

$$P = 20 + 10e^{\frac{t}{50}}$$

where  $P$  is the population in thousands and  $t$  is the time in years after the year 2000.

- (a) State the population in the year 2000.
- (b) Use the model to predict the population in the year 2020.
- (c) Sketch the graph of  $P$  against  $t$  for the years 2000 to 2100.

#### Solution:

$$P = 20 + 10e^{\frac{t}{50}}$$

- (a) The year 2000 corresponds to  $t = 0$ .

Substitute  $t = 0$  into  $P = 20 + 10e^{\frac{t}{50}}$

$$P = 20 + 10 \times e^0 = 20 + 10 \times 1 = 30$$

Population = 30 thousand

- (b) The year 2020 corresponds to  $t = 20$ .

Substitute  $t = 20$  into  $P = 20 + 10e^{\frac{t}{50}}$

$$P = 20 + 10e^{\frac{20}{50}} = 20 + 14.918 = 34.918 \text{ thousand}$$

Population in 2020 will be 34 918



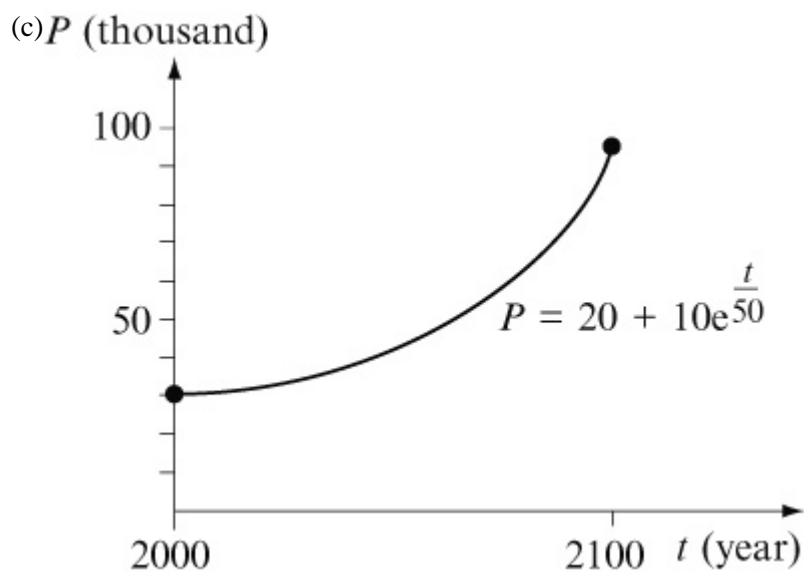

Year 2100 is  $t = 100$

$$P = 20 + 10e^{\frac{100}{50}} = 20 + 10e^2 = 93.891 \text{ thousand}$$

© Pearson Education Ltd 2008

# Solutionbank

## Edexcel AS and A Level Modular Mathematics

### Exercise A, Question 4

#### Question:

The number of people infected with a disease varies according to the formula

$$N = 300 - 100e^{-0.5t}$$

where  $N$  is the number of people infected with the disease and  $t$  is the time in years after detection.

- How many people were first diagnosed with the disease?
- What is the long term prediction of how this disease will spread?
- Graph  $N$  against  $t$ .

#### Solution:

$$N = 300 - 100e^{-0.5t}$$

(a) The number *first* diagnosed means when  $t = 0$ .

Substitute  $t = 0$  in  $N = 300 - 100e^{-0.5t}$

$$N = 300 - 100 \times e^{-0.5 \times 0} = 300 - 100 \times 1 = 200$$

(b) The long term prediction suggests  $t \rightarrow \infty$ .

As  $t \rightarrow \infty$ ,  $e^{-0.5t} \rightarrow 0$

$$\text{So } N \rightarrow 300 - 100 \times 0 = 300$$

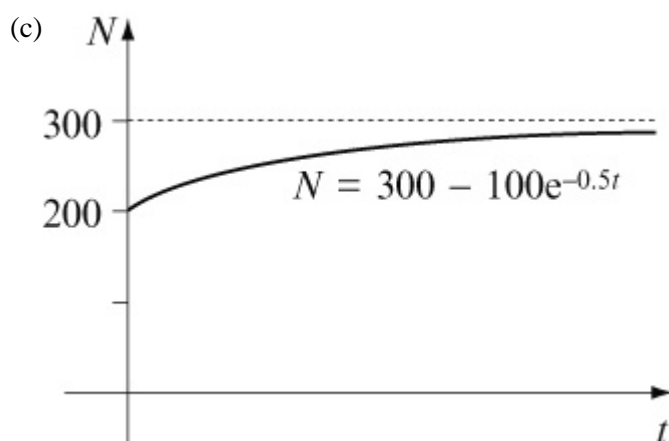

# Solutionbank

## Edexcel AS and A Level Modular Mathematics

### Exercise A, Question 5

#### Question:

The value of an investment varies according to the formula

$$V = A e^{\frac{t}{12}}$$

where  $V$  is the value of the investment in £'s,  $A$  is a constant to be found and  $t$  is the time in years after the investment was made.

- If the investment was worth £8000 after 3 years find  $A$  to the nearest £.
- Find the value of the investment after 10 years.
- By what factor will the original investment have increased by after 20 years?

#### Solution:

$$V = A e^{\frac{t}{12}}$$

- (a) We are given that  $V = 8000$  when  $t = 3$ .

Substituting gives

$$8000 = A e^{\frac{3}{12}}$$

$$8000 = A e^{\frac{1}{4}} \quad \left( \div e^{\frac{1}{4}} \right)$$

$$A = \frac{8000}{e^{\frac{1}{4}}}$$

$$A = 8000 e^{-\frac{1}{4}}$$

$$A = 6230.41$$

$$A = \text{£}6230 \text{ (to the nearest £)}$$

- (b) Hence  $V = \left( 8000 \times e^{-\frac{1}{4}} \right) e^{\frac{t}{12}}$  (use real value)

After 10 years

$$V = 8000 \times e^{-\frac{1}{4}} \times e^{\frac{10}{12}} \quad \text{(use laws of indices)}$$

$$= 8000 \times e^{\frac{10}{12} - \frac{3}{12}}$$

$$= 8000 e^{\frac{7}{12}}$$

$$= £14\,336.01$$

Investment is worth £14 336 (to nearest £) after 10 years.

(c) After 20 years  $V = Ae^{\frac{20}{12}}$

This is  $e^{\frac{20}{12}}$  times the original amount  $A$   
= 5.29 times.

© Pearson Education Ltd 2008

# Solutionbank

## Edexcel AS and A Level Modular Mathematics

### Exercise B, Question 1

#### Question:

Solve the following equations giving exact solutions:

(a)  $e^x = 5$

(b)  $\ln x = 4$

(c)  $e^{2x} = 7$

(d)  $\ln \frac{x}{2} = 4$

(e)  $e^{x-1} = 8$

(f)  $\ln (2x + 1) = 5$

(g)  $e^{-x} = 10$

(h)  $\ln (2 - x) = 4$

(i)  $2e^{4x} - 3 = 8$

#### Solution:

(a)  $e^x = 5 \Rightarrow x = \ln 5$

(b)  $\ln x = 4 \Rightarrow x = e^4$

(c)  $e^{2x} = 7 \Rightarrow 2x = \ln 7 \Rightarrow x = \frac{\ln 7}{2}$

(d)  $\ln \left( \frac{x}{2} \right) = 4 \Rightarrow \frac{x}{2} = e^4 \Rightarrow x = 2e^4$

(e)  $e^{x-1} = 8 \Rightarrow x - 1 = \ln 8 \Rightarrow x = \ln 8 + 1$

(f)  $\ln (2x + 1) = 5$   
 $\Rightarrow 2x + 1 = e^5$

$$\Rightarrow 2x = e^5 - 1$$

$$\Rightarrow x = \frac{e^5 - 1}{2}$$

$$(g) e^{-x} = 10$$

$$\Rightarrow -x = \ln 10$$

$$\Rightarrow x = -\ln 10$$

$$\Rightarrow x = \ln 10^{-1}$$

$$\Rightarrow x = \ln (0.1)$$

$$(h) \ln (2 - x) = 4$$

$$\Rightarrow 2 - x = e^4$$

$$\Rightarrow 2 = e^4 + x$$

$$\Rightarrow x = 2 - e^4$$

$$(i) 2e^{4x} - 3 = 8$$

$$\Rightarrow 2e^{4x} = 11$$

$$\Rightarrow e^{4x} = \frac{11}{2}$$

$$\Rightarrow 4x = \ln \left( \frac{11}{2} \right)$$

$$\Rightarrow x = \frac{1}{4} \ln \left( \frac{11}{2} \right)$$

# Solutionbank

## Edexcel AS and A Level Modular Mathematics

### Exercise B, Question 2

#### Question:

Solve the following giving your solution in terms of  $\ln 2$ :

(a)  $e^{3x} = 8$

(b)  $e^{-2x} = 4$

(c)  $e^{2x+1} = 0.5$

#### Solution:

(a)  $e^{3x} = 8$

$$\Rightarrow 3x = \ln 8$$

$$\Rightarrow 3x = \ln 2^3$$

$$\Rightarrow 3x = 3 \ln 2$$

$$\Rightarrow x = \ln 2$$

(b)  $e^{-2x} = 4$

$$\Rightarrow -2x = \ln 4$$

$$\Rightarrow -2x = \ln 2^2$$

$$\Rightarrow -2x = 2 \ln 2$$

$$\Rightarrow x = \frac{2 \ln 2}{-2}$$

$$\Rightarrow x = -1 \ln 2$$

(c)  $e^{2x+1} = 0.5$

$$\Rightarrow 2x + 1 = \ln (0.5)$$

$$\Rightarrow 2x + 1 = \ln 2^{-1}$$

$$\Rightarrow 2x + 1 = -\ln 2$$

$$\Rightarrow 2x = -\ln 2 - 1$$

$$\Rightarrow x = \frac{-\ln 2 - 1}{2}$$





# Solutionbank

## Edexcel AS and A Level Modular Mathematics

### Exercise B, Question 3

#### Question:

Sketch the following graphs stating any asymptotes and intersections with axes:

(a)  $y = \ln(x + 1)$

(b)  $y = 2 \ln x$

(c)  $y = \ln(2x)$

(d)  $y = (\ln x)^2$

(e)  $y = \ln(4 - x)$

(f)  $y = 3 + \ln(x + 2)$

#### Solution:

(a)  $y = \ln(x + 1)$

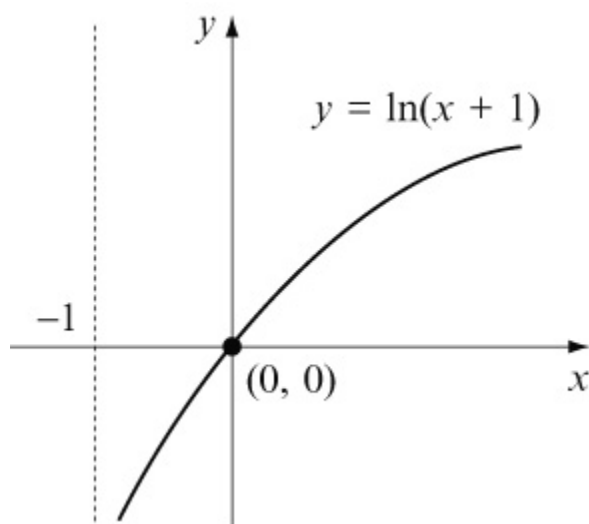

When  $x = 0$ ,  $y = \ln(1) = 0$

When  $x \rightarrow -1$ ,  $y \rightarrow -\infty$

$y$  wouldn't exist for values of  $x < -1$

When  $x \rightarrow \infty$ ,  $y \rightarrow \infty$  (slowly)

(b)  $y = 2 \ln x$

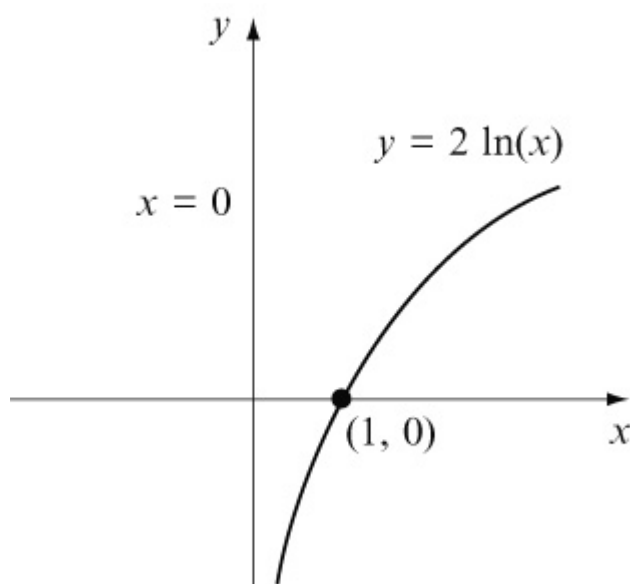

When  $x = 1$ ,  $y = 2 \ln(1) = 0$

When  $x \rightarrow 0$ ,  $y \rightarrow -\infty$

$y$  wouldn't exist for values of  $x < 0$

When  $x \rightarrow \infty$ ,  $y \rightarrow \infty$  (slowly)

(c)  $y = \ln(2x)$

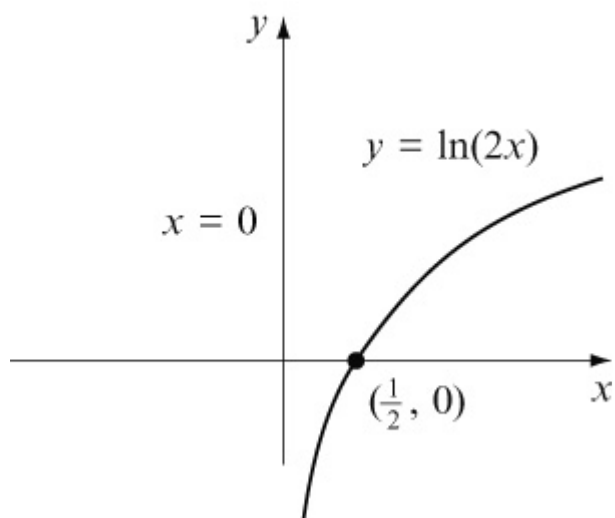

When  $x = \frac{1}{2}$ ,  $y = \ln(1) = 0$

When  $x \rightarrow 0$ ,  $y \rightarrow -\infty$

$y$  wouldn't exist for values of  $x < 0$

When  $x \rightarrow \infty$ ,  $y \rightarrow \infty$  (slowly)

(d)  $y = (\ln x)^2$

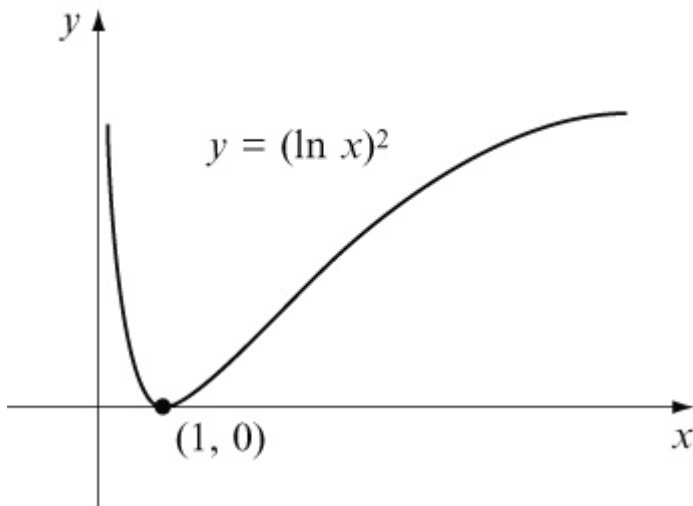

When  $x = 1$ ,  $y = (\ln 1)^2 = 0$

For  $0 < x < 1$ ,  $\ln x$  is negative, but  $(\ln x)^2$  is positive.

When  $x \rightarrow 0$ ,  $y \rightarrow \infty$

When  $x \rightarrow \infty$ ,  $y \rightarrow \infty$

(e)  $y = \ln(4 - x)$

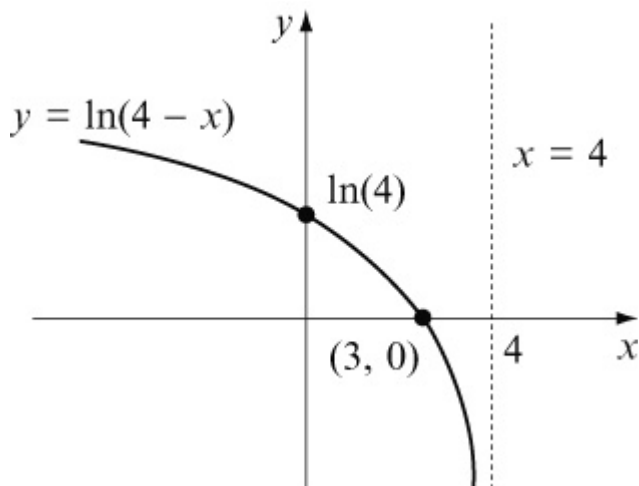

When  $x = 3$ ,  $y = \ln 1 = 0$

When  $x \rightarrow 4$ ,  $y \rightarrow -\infty$

$y$  doesn't exist for values of  $x > 4$

When  $x \rightarrow -\infty$ ,  $y \rightarrow \infty$  (slowly)

When  $x = 0$ ,  $y = \ln 4$

(f)  $y = 3 + \ln(x + 2)$

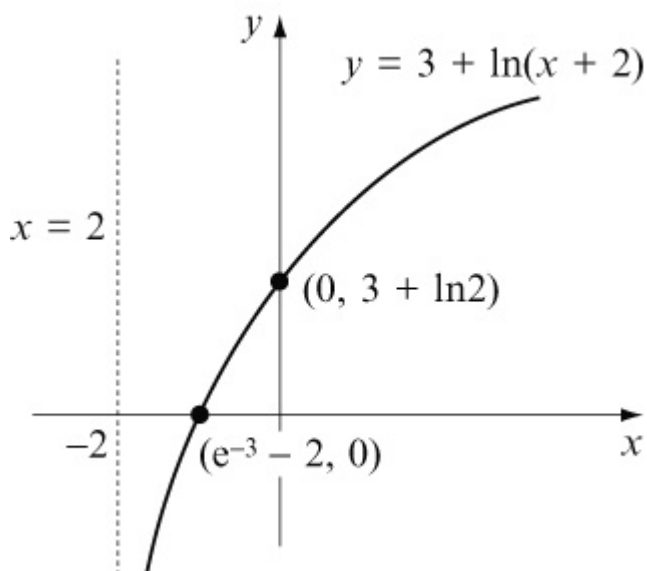

When  $x = -1$ ,  $y = 3 + \ln 1 = 3 + 0 = 3$

When  $x \rightarrow -2$ ,  $y \rightarrow -\infty$

$y$  doesn't exist for values of  $x < -2$

When  $x \rightarrow \infty$ ,  $y \rightarrow \infty$  slowly

When  $x = 0$ ,  $y = 3 + \ln(0 + 2) = 3 + \ln 2$

When  $y = 0$ ,

$$0 = 3 + \ln(x + 2)$$

$$-3 = \ln(x + 2)$$

$$e^{-3} = x + 2$$

$$x = e^{-3} - 2$$

# Solutionbank

## Edexcel AS and A Level Modular Mathematics

### Exercise B, Question 4

#### Question:

The price of a new car varies according to the formula

$$P = 15\,000e^{-\frac{t}{10}}$$

where  $P$  is the price in £'s and  $t$  is the age in years from new.

- State its new value.
- Calculate its value after 5 years (to the nearest £).
- Find its age when its price falls below £5 000.
- Sketch the graph showing how the price varies over time. Is this a good model?

#### Solution:

$$P = 15\,000e^{-\frac{t}{10}}$$

$$(a) \text{ New value is when } t = 0 \Rightarrow P = 15\,000 \times e^0 = 15\,000$$

The new value is £15 000

$$(b) \text{ Value after 5 years is when } t = 5$$

$$\Rightarrow P = 15\,000 \times e^{-\frac{5}{10}} = 15\,000e^{-0.5} = 9097.96$$

Value after 5 years is £9 098 (to nearest £)

$$(c) \text{ Find when price is } £5\,000$$

Substitute  $P = 5\,000$ :

$$5\,000 = 15\,000e^{-\frac{t}{10}} \quad (\div 15\,000)$$

$$\frac{5\,000}{15\,000} = e^{-\frac{t}{10}}$$

$$\frac{1}{3} = e^{-\frac{t}{10}}$$

$$\ln \left( \frac{1}{3} \right) = -\frac{t}{10}$$

$$t = -10 \ln \left( \frac{1}{3} \right)$$

$$t = 10 \ln \left( \frac{1}{3} \right) - 1$$

$$t = 10 \ln 3$$

$$t = 10.99 \text{ years}$$

The price falls below £5 000 after 11 years.

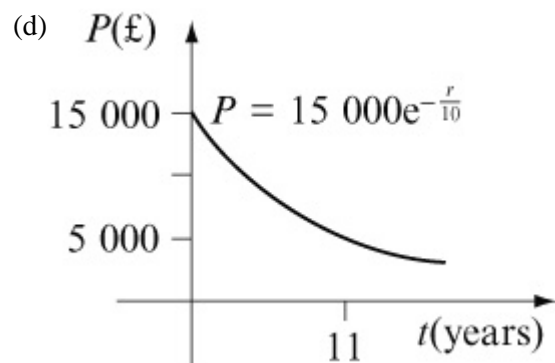

A fair model! Perhaps the price should be lower after 11 years.

© Pearson Education Ltd 2008

# Solutionbank

## Edexcel AS and A Level Modular Mathematics

### Exercise B, Question 5

#### Question:

The graph below is of the function

$$f(x) = \ln(2 + 3x) \quad \{x \in \mathbb{R}, x > a\}.$$

- (a) State the value of  $a$ .
- (b) Find the value of  $s$  for which  $f(s) = 20$ .
- (c) Find the function  $f^{-1}(x)$  stating its domain.
- (d) Sketch the graphs  $f(x)$  and  $f^{-1}(x)$  on the same axes stating the relationship between them.

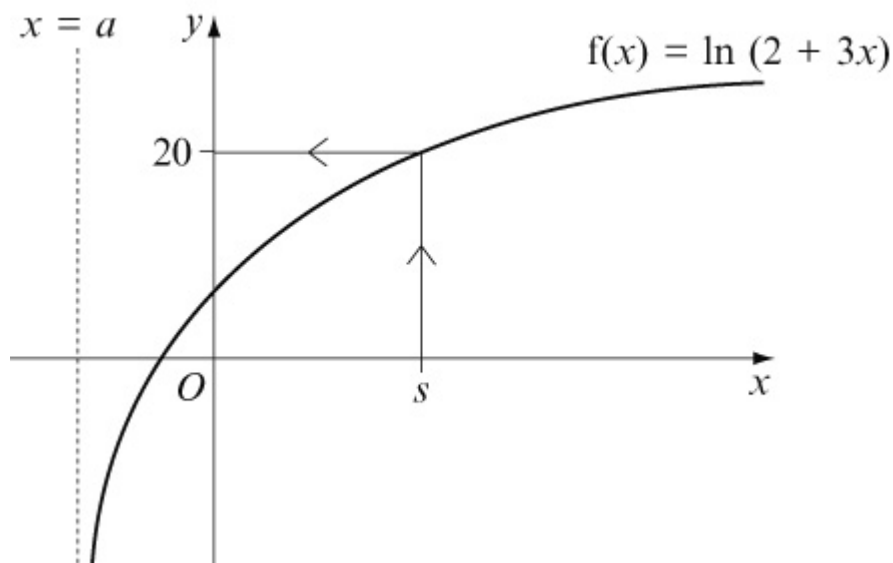

#### Solution:

(a)  $x = a$  is the asymptote to the curve. It will be where

$$2 + 3x = 0$$

$$3x = -2$$

$$x = -\frac{2}{3}$$

$$\text{Hence } a = -\frac{2}{3}$$

(b) If  $f(s) = 20$  then

$$\ln(2 + 3s) = 20$$

$$2 + 3s = e^{20}$$

$$3s = e^{20} - 2$$

$$s = \frac{e^{20} - 2}{3}$$

(c) To find  $f^{-1}(x)$ , change the subject of the formula.

$$y = \ln(2 + 3x)$$

$$e^y = 2 + 3x$$

$$e^y - 2 = 3x$$

$$x = \frac{e^y - 2}{3}$$

$$\text{Therefore } f^{-1}(x) = \frac{e^x - 2}{3}$$

domain of  $f^{-1}(x) = \text{range of } f(x)$ , so  $x \in \mathbb{R}$

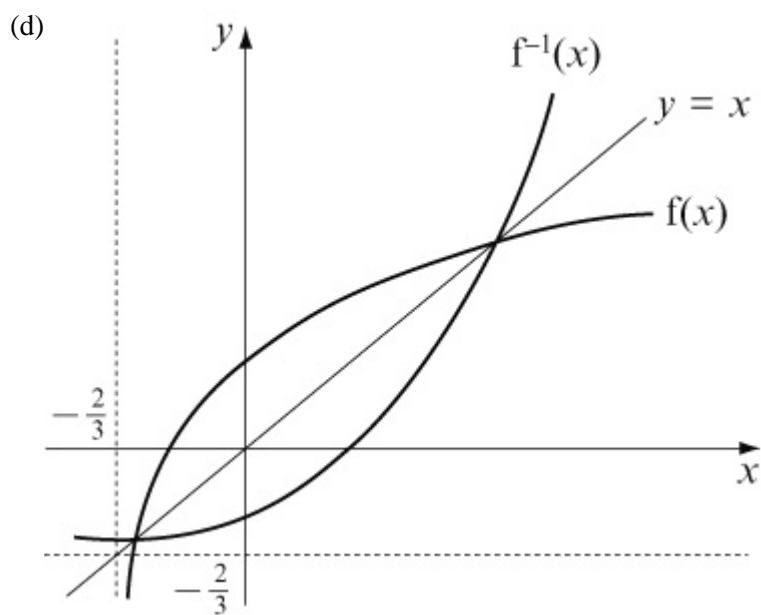

$f^{-1}(x)$  is a reflection of  $f(x)$  in the line  $y = x$ .



# Solutionbank

## Edexcel AS and A Level Modular Mathematics

### Exercise B, Question 6

#### Question:

The graph below is of the function

$$g(x) = 2e^{2x} + 4 \quad \{ x \in \mathbb{R} \} .$$

- (a) Find the range of the function.
- (b) Find the value of  $p$  to 2 significant figures.
- (c) Find  $g^{-1}(x)$  stating its domain.
- (d) Sketch  $g(x)$  and  $g^{-1}(x)$  on the same set of axes stating the relationship between them.

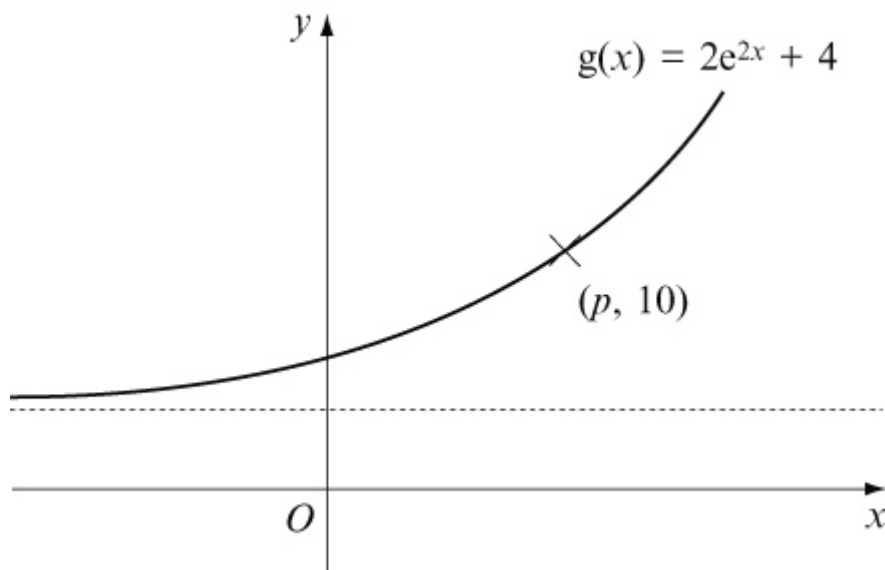

#### Solution:

(a)  $g(x) = 2e^{2x} + 4$

As  $x \rightarrow -\infty$ ,  $g(x) \rightarrow 2 \times 0 + 4 = 4$

Therefore the range of  $g(x)$  is  $g(x) > 4$

(b) If  $(p, 10)$  lies on  $g(x) = 2e^{2x} + 4$

$$2e^{2p} + 4 = 10$$

$$2e^{2p} = 6$$

$$e^{2p} = 3$$

$$2p = \ln 3$$

$$p = \frac{1}{2} \ln 3$$

$$p = 0.55 \text{ (2 s.f.)}$$

(c)  $g^{-1}(x)$  is found by changing the subject of the formula.

$$\text{Let } y = 2e^{2x} + 4$$

$$y - 4 = 2e^{2x}$$

$$\frac{y-4}{2} = e^{2x}$$

$$\ln \left( \frac{y-4}{2} \right) = 2x$$

$$x = \frac{1}{2} \ln \left( \frac{y-4}{2} \right)$$

$$\text{Hence } g^{-1}(x) = \frac{1}{2} \ln \left( \frac{x-4}{2} \right)$$

Its domain is the same as the range of  $g(x)$ .

$g^{-1}(x)$  has a domain of  $x > 4$

(d)

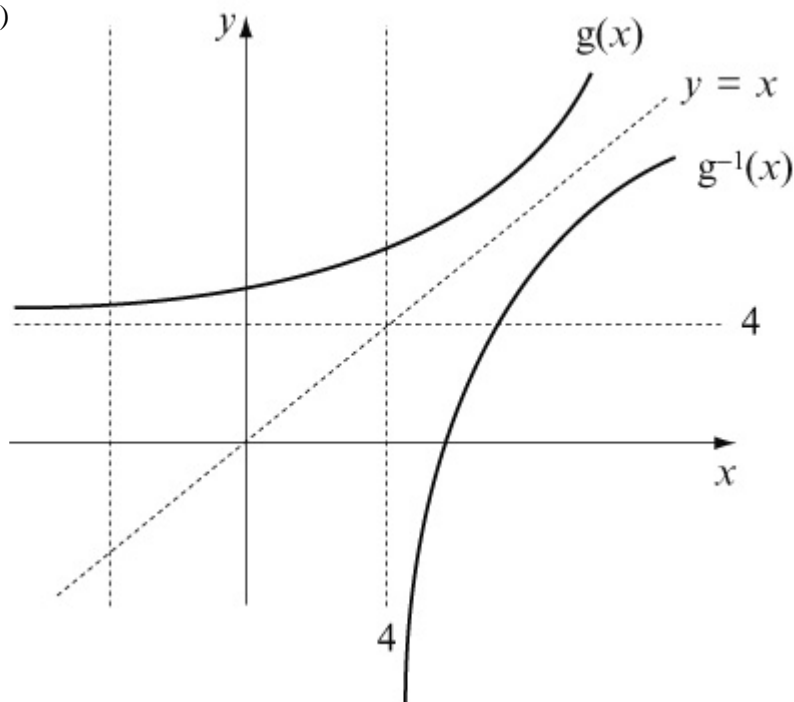

$g^{-1}(x)$  is a reflection of  $g(x)$  in the line  $y = x$ .

# Solutionbank

## Edexcel AS and A Level Modular Mathematics

### Exercise B, Question 7

#### Question:

The number of bacteria in a culture grows according to the following equation:

$$N = 100 + 50e^{\frac{t}{30}}$$

where  $N$  is the number of bacteria present and  $t$  is the time in days from the start of the experiment.

- State the number of bacteria present at the start of the experiment.
- State the number after 10 days.
- State the day on which the number first reaches 1 000 000.
- Sketch the graph showing how  $N$  varies with  $t$ .

#### Solution:

$$N = 100 + 50e^{\frac{t}{30}}$$

- (a) At the start  $t = 0$

$$\Rightarrow N = 100 + 50e^{\frac{0}{30}} = 100 + 50 \times 1 = 150$$

There are 150 bacteria present at the start.

- (b) After 10 days  $t = 10$

$$\Rightarrow N = 100 + 50e^{\frac{10}{30}} = 100 + 50e^{\frac{1}{3}} = 170$$

There are 170 bacteria present after 10 days.

- (c) When  $N = 1\,000\,000$

$$1\,000\,000 = 100 + 50e^{\frac{t}{30}} \quad ( - 100 )$$

$$999\,900 = 50e^{\frac{t}{30}} \quad ( \div 50 )$$

$$19\,998 = e^{\frac{t}{30}}$$

$$\ln ( 19\,998 ) = \frac{t}{30}$$

$$t = 30 \ln ( 19\,998 )$$

$$t = 297.10$$

The number of bacteria reaches 1 000 000 on the 298th day (to the nearest day).

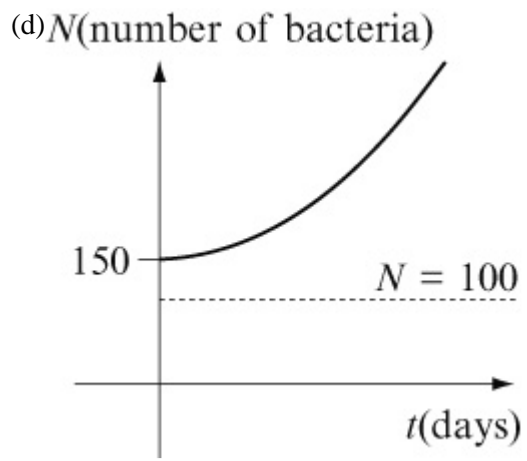

© Pearson Education Ltd 2008

# Solutionbank

## Edexcel AS and A Level Modular Mathematics

### Exercise B, Question 8

#### Question:

The graph below shows the function

$$h(x) = 40 - 10e^{3x} \quad \{ x > 0, x \in \mathbb{R} \} .$$

- State the range of the function.
- Find the exact coordinates of A in terms of  $\ln 2$ .
- Find  $h^{-1}(x)$  stating its domain.

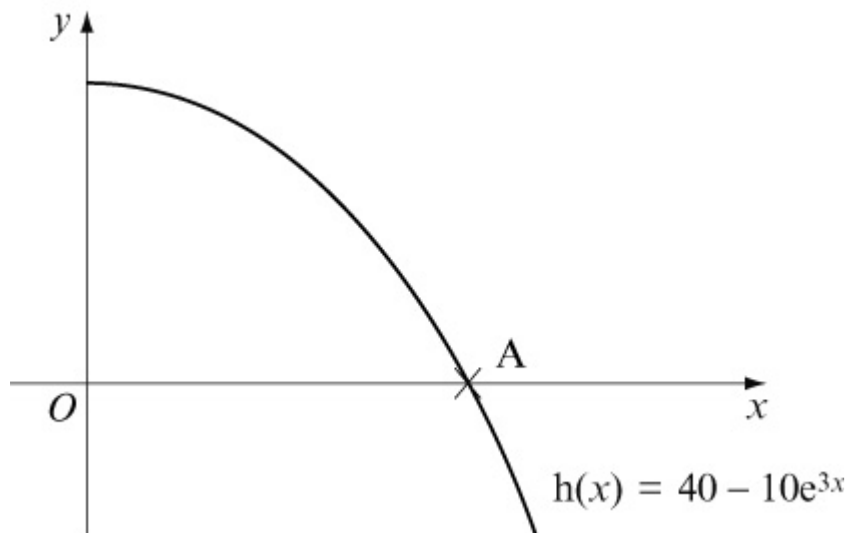

#### Solution:

$$(a) h(x) = 40 - 10e^{3x}$$

The range is the set of values that  $y$  can take.

$$h(0) = 40 - 10e^0 = 40 - 10 = 30$$

Hence range is  $h(x) < 30$

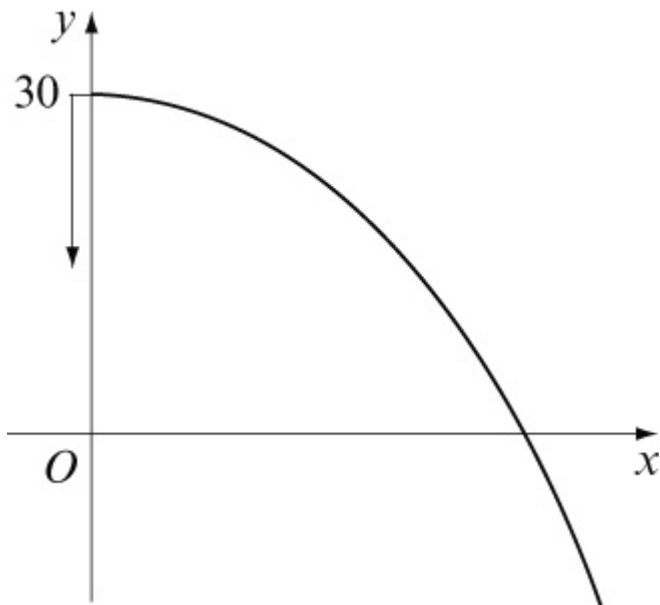

(b) A is where  $y = 0$

$$\text{Solve } 40 - 10e^{3x} = 0$$

$$40 = 10e^{3x} \quad (\div 10)$$

$$4 = e^{3x}$$

$$\ln 4 = 3x$$

$$x = \frac{1}{3} \ln 4$$

$$x = \frac{1}{3} \ln 2^2$$

$$x = \frac{2}{3} \ln 2$$

$$\text{A is } \left( \frac{2}{3} \ln 2, 0 \right)$$

(c) To find  $h^{-1}(x)$  change the subject of the formula.

$$\text{Let } y = 40 - 10e^{3x}$$

$$10e^{3x} = 40 - y$$

$$e^{3x} = \frac{40 - y}{10}$$

$$3x = \ln \left( \frac{40 - y}{10} \right)$$

$$x = \frac{1}{3} \ln \left( \frac{40 - y}{10} \right)$$

The domain of the inverse function is the same as the range of the function.

$$\text{Hence } h^{-1}(x) = \frac{1}{3} \ln \left( \frac{40 - x}{10} \right) \quad \{ x \in \mathbb{R}, x < 30 \}$$

© Pearson Education Ltd 2008

# Solutionbank

## Edexcel AS and A Level Modular Mathematics

### Exercise C, Question 1

#### Question:

Sketch the following functions stating any asymptotes and intersections with axes:

(a)  $y = e^x + 3$

(b)  $y = \ln(-x)$

(c)  $y = \ln(x + 2)$

(d)  $y = 3e^{-2x} + 4$

(e)  $y = e^{x+2}$

(f)  $y = 4 - \ln x$

#### Solution:

(a)  $y = e^x + 3$

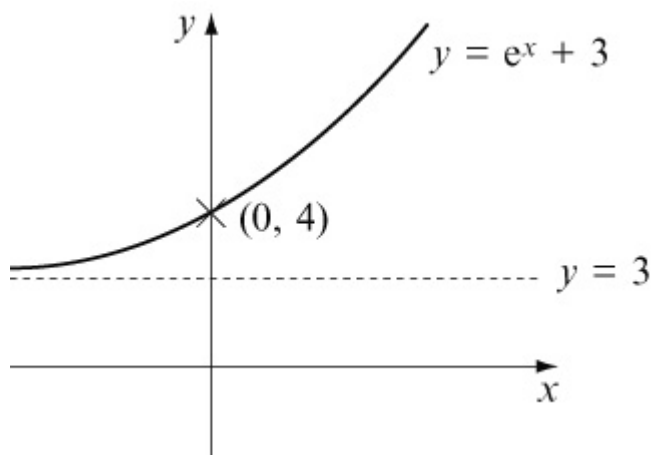

This is the graph of  $y = e^x$  'moved up' 3 units.

$$x = 0, \quad y = e^0 + 3 = 1 + 3 = 4$$

(b)  $y = \ln(-x)$



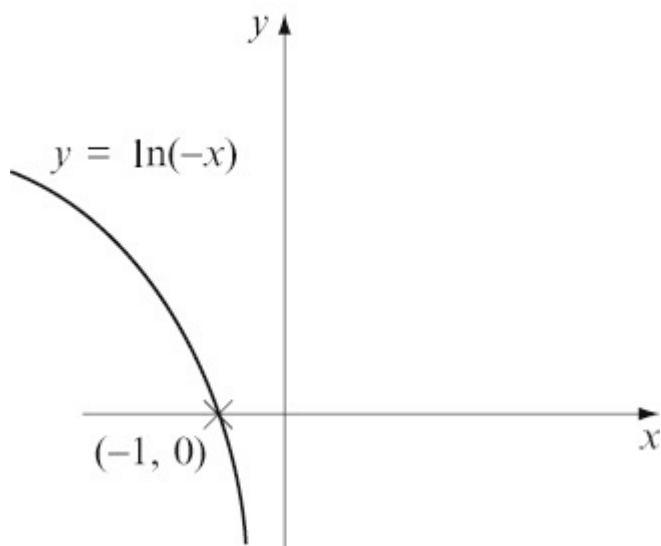

$$x = -1, \quad y = \ln(-(-1)) = \ln(1) = 0$$

$y$  will not exist for values of  $x > 0$

$x \rightarrow -\infty, \quad y \rightarrow \infty$  (slowly)

The graph will be a reflection of  $y = \ln(x)$  in the  $y$  axis.

(c)  $y = \ln(x + 2)$

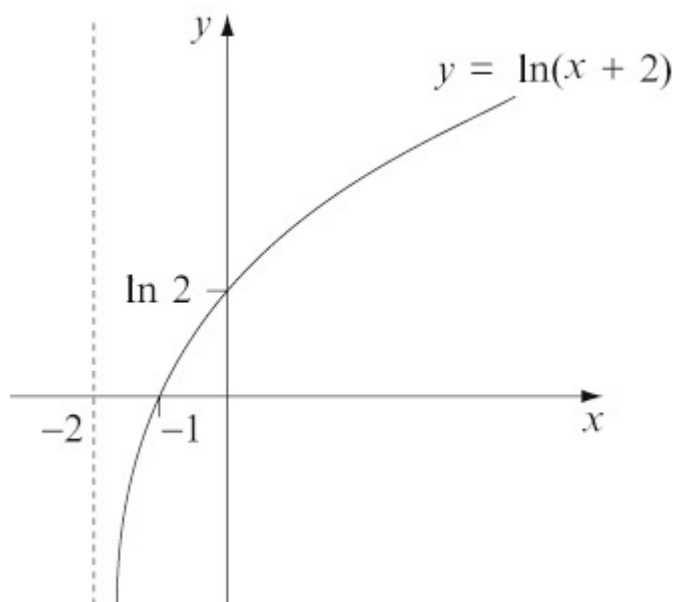

$$x = -1, \quad y = \ln(-1 + 2) = \ln(1) = 0$$

$y$  will not exist for values of  $x < -2$

$x \rightarrow -2, \quad y \rightarrow -\infty$

$x \rightarrow \infty, \quad y \rightarrow \infty$  (slowly)

$$x = 0, \quad y = \ln(0 + 2) = \ln 2$$

(d)  $y = 3e^{-2x} + 4$

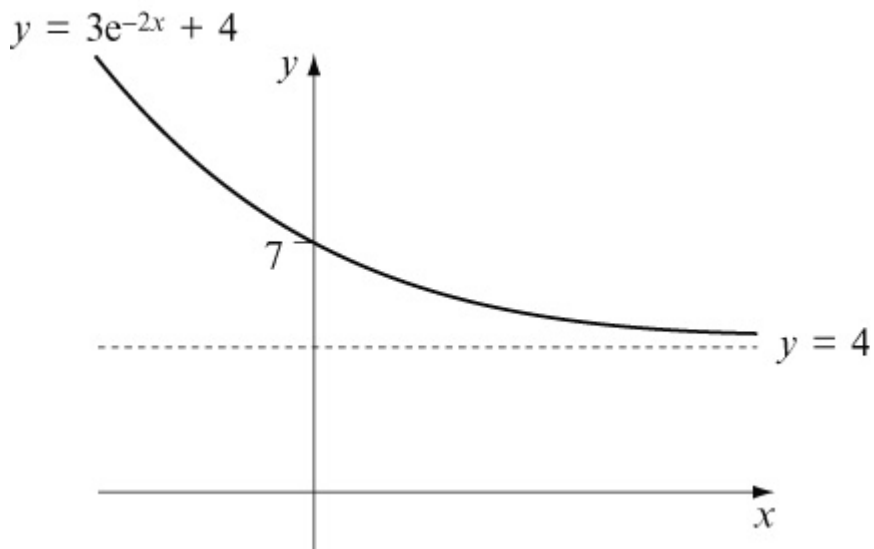

$$x = 0, \quad y = 3e^0 + 4 = 3 + 4 = 7$$

$$x \rightarrow \infty, \quad y \rightarrow 3 \times 0 + 4 = 4$$

$$x \rightarrow -\infty, \quad y \rightarrow \infty$$

(e)  $y = e^{x+2}$

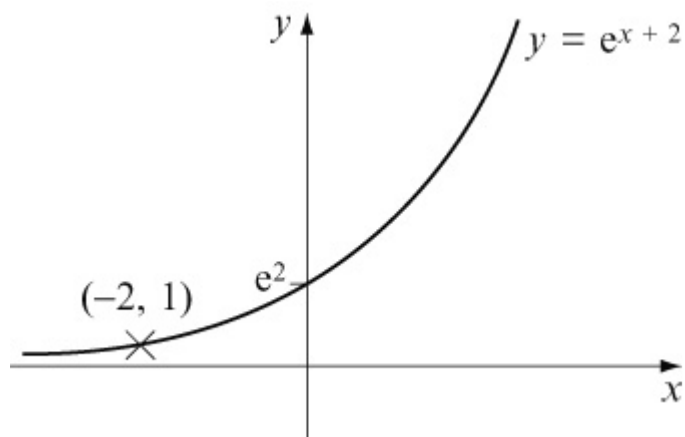

$$x = -2, \quad y = e^{-2+2} = e^0 = 1$$

$$x \rightarrow -\infty, \quad y \rightarrow 0$$

$$x \rightarrow \infty, \quad y \rightarrow \infty$$

$$x = 0, \quad y = e^2$$

(f)  $y = 4 - \ln x$

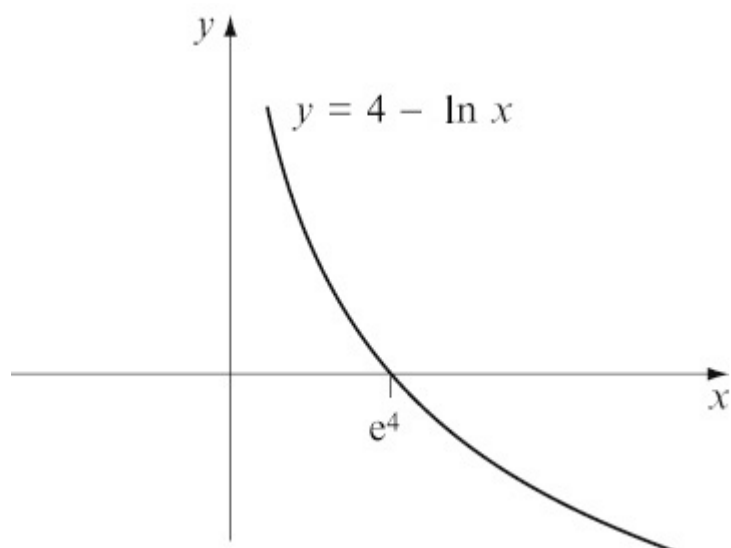

$$x = 1, \quad y = 4 - \ln(1) = 4$$

$$x \rightarrow 0, \quad y \rightarrow 4 - (-\infty), \text{ so } y \rightarrow +\infty$$

$y$  will not exist for values of  $x < 0$

$$y = 0 \Rightarrow 4 - \ln x = 0 \Rightarrow \ln x = 4 \Rightarrow x = e^4$$

# Solutionbank

## Edexcel AS and A Level Modular Mathematics

### Exercise C, Question 2

#### Question:

Solve the following equations, giving exact solutions:

(a)  $\ln ( 2x - 5 ) = 8$

(b)  $e^{4x} = 5$

(c)  $24 - e^{-2x} = 10$

(d)  $\ln x + \ln ( x - 3 ) = 0$

(e)  $e^x + e^{-x} = 2$

(f)  $\ln 2 + \ln x = 4$

#### Solution:

(a)  $\ln ( 2x - 5 ) = 8$  (inverse of  $\ln$ )

$$2x - 5 = e^8 \quad ( + 5 )$$

$$2x = e^8 + 5 \quad ( \div 2 )$$

$$x = \frac{e^8 + 5}{2}$$

(b)  $e^{4x} = 5$  (inverse of  $e$ )

$$4x = \ln 5 \quad ( \div 4 )$$

$$x = \frac{\ln 5}{4}$$

(c)  $24 - e^{-2x} = 10$  (  $+ e^{-2x}$  )

$$24 = 10 + e^{-2x} \quad ( - 10 )$$

$$14 = e^{-2x} \quad (\text{inverse of } e)$$

$$\ln ( 14 ) = - 2x \quad ( \div - 2 )$$

$$- \frac{1}{2} \ln ( 14 ) = x$$

$$x = - \frac{1}{2} \ln ( 14 )$$

$$(d) \ln(x) + \ln(x - 3) = 0$$

$$\ln[x(x - 3)] = 0$$

$$x(x - 3) = e^0$$

$$x(x - 3) = 1$$

$$x^2 - 3x - 1 = 0$$

$$x = \frac{3 \pm \sqrt{9 + 4}}{2}$$

$$x = \frac{3 \pm \sqrt{13}}{2}$$

$$x = \frac{3 + \sqrt{13}}{2}$$

(x cannot be negative because of initial equation)

$$(e) e^x + e^{-x} = 2$$

$$e^x + \frac{1}{e^x} = 2 \quad (\times e^x)$$

$$(e^x)^2 + 1 = 2e^x$$

$$(e^x)^2 - 2e^x + 1 = 0$$

$$(e^x - 1)^2 = 0$$

$$e^x = 1$$

$$x = \ln 1 = 0$$

$$(f) \ln 2 + \ln x = 4$$

$$\ln 2x = 4$$

$$2x = e^{\text{hairsp};4}$$

$$x = \frac{e^{\text{hairsp};4}}{2}$$

# Solutionbank

## Edexcel AS and A Level Modular Mathematics

### Exercise C, Question 3

#### Question:

The function  $c(x) = 3 + \ln(4 - x)$  is shown below.

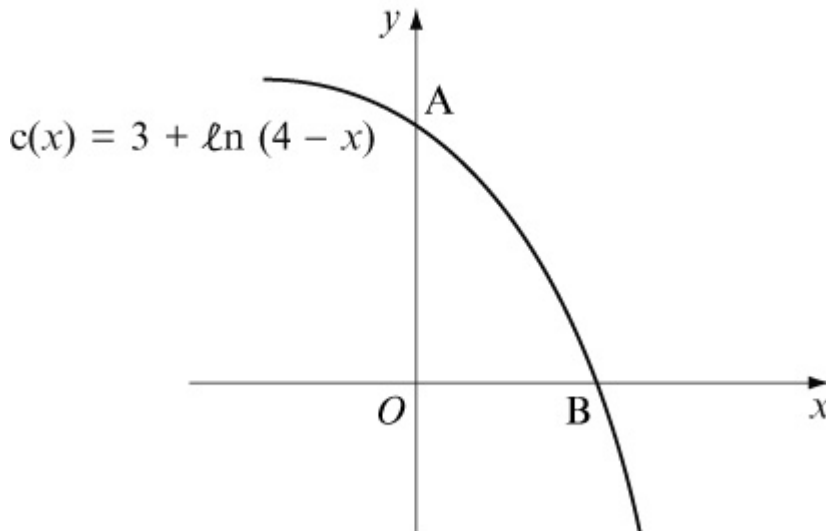

- State the exact coordinates of point A.
- Calculate the exact coordinates of point B.
- Find the inverse function  $c^{-1}(x)$  stating its domain.
- Sketch  $c(x)$  and  $c^{-1}(x)$  on the same set of axes stating the relationship between them.

#### Solution:

(a) A is where  $x = 0$

Substitute  $x = 0$  into  $y = 3 + \ln(4 - x)$  to give

$$y = 3 + \ln 4$$

$$A = (0, 3 + \ln 4)$$

(b) B is where  $y = 0$

Substitute  $y = 0$  into  $y = 3 + \ln(4 - x)$  to give

$$0 = 3 + \ln(4 - x)$$

$$-3 = \ln(4 - x)$$

$$e^{-3} = 4 - x$$

$$x = 4 - e^{-3}$$

$$B = (4 - e^{-3}, 0)$$

(c) To find  $c^{-1}(x)$  change the subject of the formula.

$$y = 3 + \ln(4 - x)$$

$$y - 3 = \ln(4 - x)$$

$$e^{y-3} = 4 - x$$

$$x = 4 - e^{y-3}$$

The domain of the inverse function is the range of the function. Looking at graph this is all the real numbers. So

$$c^{-1}(x) = 4 - e^{x-3} \quad \{x \in \mathbb{R}\}$$

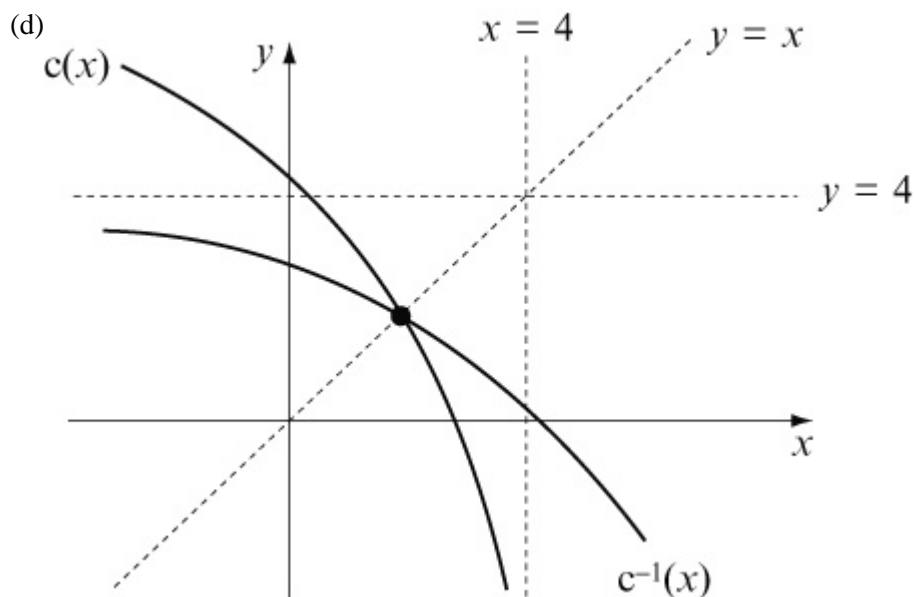

© Pearson Education Ltd 2008

# Solutionbank

## Edexcel AS and A Level Modular Mathematics

### Exercise C, Question 4

#### Question:

The price of a computer system can be modelled by the formula

$$P = 100 + 850e^{-\frac{t}{2}}$$

where  $P$  is the price of the system in £s and  $t$  is the age of the computer in years after being purchased.

- Calculate the new price of the system.
- Calculate its price after 3 years.
- When will it be worth less than £200?
- Find its price as  $t \rightarrow \infty$ .
- Sketch the graph showing  $P$  against  $t$ .  
Comment on the appropriateness of this model.

#### Solution:

$$P = 100 + 850e^{-\frac{t}{2}}$$

- New price is when  $t = 0$ .

Substitute  $t = 0$  into  $P = 100 + 850e^{-\frac{t}{2}}$  to give

$$\begin{aligned} P &= 100 + 850e^{-\frac{0}{2}} \quad (e^0 = 1) \\ &= 100 + 850 = 950 \end{aligned}$$

The new price is £950

- After 3 years  $t = 3$ .

Substitute  $t = 3$  into  $P = 100 + 850e^{-\frac{t}{2}}$  to give

$$P = 100 + 850e^{-\frac{3}{2}} = 289.66$$

Price after 3 years is £290 (to nearest £)

- It is worth less than £200 when  $P < 200$

Substitute  $P = 200$  into  $P = 100 + 850e^{-\frac{t}{2}}$  to give



$$200 = 100 + 850e^{-\frac{t}{2}}$$

$$100 = 850e^{-\frac{t}{2}}$$

$$\frac{100}{850} = e^{-\frac{t}{2}}$$

$$\ln\left(\frac{100}{850}\right) = -\frac{t}{2}$$

$$t = -2\ln\left(\frac{100}{850}\right)$$

$$t = 4.28$$

It is worth less than £200 after 4.28 years.

(d) As  $t \rightarrow \infty$ ,  $e^{-\frac{t}{2}} \rightarrow 0$

Hence  $P \rightarrow 100 + 850 \times 0 = 100$

The computer will be worth £100 eventually.

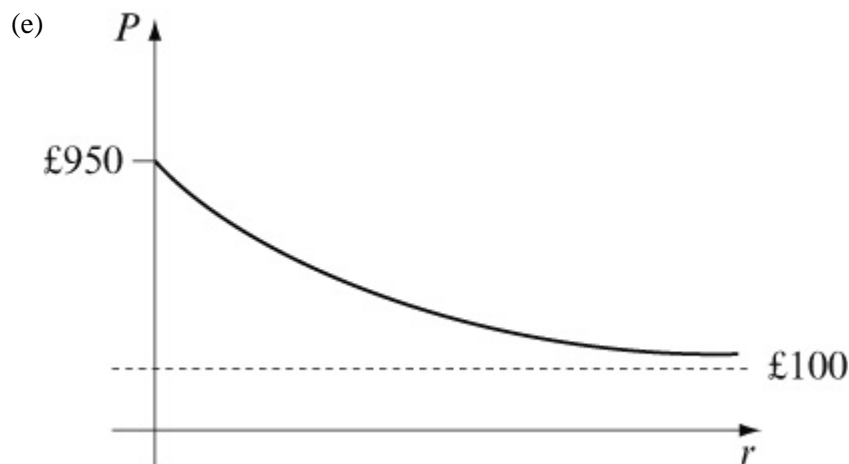

© Pearson Education Ltd 2008

# Solutionbank

## Edexcel AS and A Level Modular Mathematics

Exercise C, Question 5

### Question:

The function  $f$  is defined by

$$f : x \rightarrow \ln ( 5x - 2 ) \quad \left\{ x \in \mathbb{R}, x > \frac{2}{5} \right\} .$$

- (a) Find an expression for  $f^{-1} ( x )$  .
- (b) Write down the domain of  $f^{-1} ( x )$  .
- (c) Solve, giving your answer to 3 decimal places,  
 $\ln ( 5x - 2 ) = 2$  .

[E]

### Solution:

(a) Let  $y = \ln ( 5x - 2 )$

$$e^y = 5x - 2$$

$$e^y + 2 = 5x$$

$$\frac{e^y + 2}{5} = x$$

The range of  $y = \ln ( 5x - 2 )$  is  $y \in \mathbb{R}$

$$\text{So } f^{-1} ( x ) = \frac{e^x + 2}{5} \quad \{ x \in \mathbb{R} \}$$

(b) Domain is  $x \in \mathbb{R}$

(c)  $\ln ( 5x - 2 ) = 2$

$$5x - 2 = e^2$$

$$5x = e^2 + 2$$

$$x = \frac{e^2 + 2}{5} = 1.8778 \quad \dots$$

$$x = 1.878 \text{ (to 3d.p.)}$$

# Solutionbank

## Edexcel AS and A Level Modular Mathematics

### Exercise C, Question 6

#### Question:

The functions  $f$  and  $g$  are given by

$$f : x \rightarrow 3x - 1 \quad \{ x \in \mathbb{R} \}$$

$$g : x \rightarrow e^{\frac{x}{2}} \quad \{ x \in \mathbb{R} \}$$

- (a) Find the value of  $fg(4)$ , giving your answer to 2 decimal places.
- (b) Express the inverse function  $f^{-1}(x)$  in the form  $f^{-1} : x \rightarrow \dots$ .
- (c) Using the same axes, sketch the graphs of the functions  $f$  and  $gf$ . Write on your sketch the value of each function at  $x = 0$ .
- (d) Find the values of  $x$  for which  $f^{-1}(x) = \frac{5}{f(x)}$ .

[E]

#### Solution:

$$\begin{aligned} \text{(a) } fg(4) &= f\left(e^{\frac{4}{2}}\right) = f(e^2) = 3e^2 - 1 \\ &= 21.17 \text{ (2d.p.)} \end{aligned}$$

$$\begin{aligned} \text{(b) If } f : x &\rightarrow 3x - 1 \quad \{ x \in \mathbb{R} \} \\ \text{then } f^{-1} : x &\rightarrow \frac{x+1}{3} \quad \left\{ x \in \mathbb{R} \right\} \end{aligned}$$

by using flow diagram method:

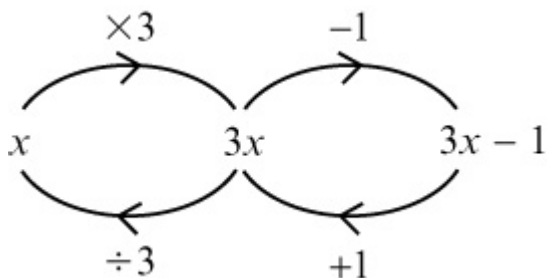

$$\text{(c) } gf(x) = g(3x - 1) = e^{\frac{3x-1}{2}} \quad f(x) = 3x - 1$$

At  $x = 0$ ,  $gf(x) = e^{\frac{0-1}{2}} = e^{-\frac{1}{2}}$  and  $f(x) = 3 \times 0 - 1 = -1$

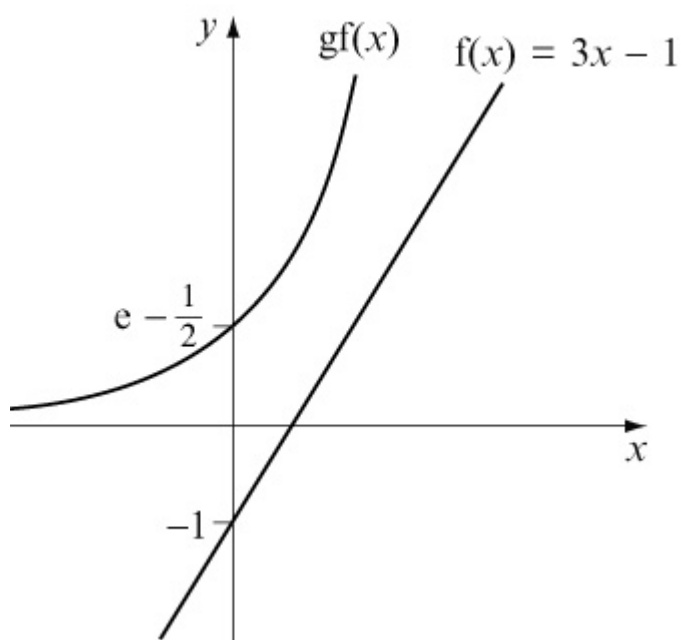

$$(d) f^{-1}(x) = \frac{5}{f(x)}$$

$$\frac{x+1}{3} = \frac{5}{3x-1} \quad (\text{cross multiply})$$

$$(x+1)(3x-1) = 5 \times 3$$

$$3x^2 + 2x - 1 = 15$$

$$3x^2 + 2x - 16 = 0$$

$$(3x+8)(x-2) = 0$$

$$x = 2, -\frac{8}{3}$$

# Solutionbank

## Edexcel AS and A Level Modular Mathematics

Exercise C, Question 7

### Question:

The points P and Q lie on the curve with equation  $y = e^{\frac{1}{2}x}$ .  
The  $x$ -coordinates of P and Q are  $\ln 4$  and  $\ln 16$  respectively.

- Find an equation for the line PQ.
- Show that this line passes through the origin O.
- Calculate the length, to 3 significant figures, of the line segment PQ.

[E]

### Solution:

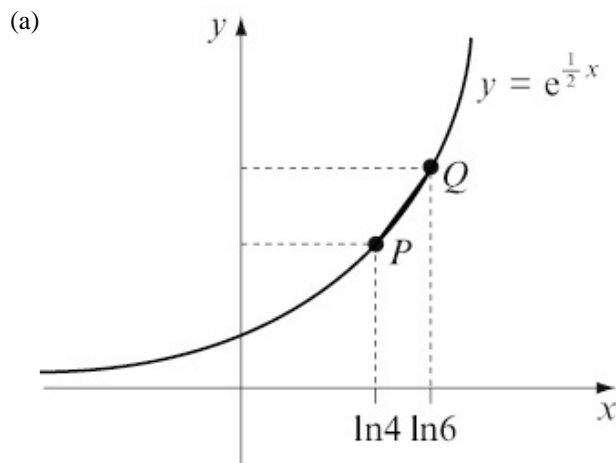

Q has  $y$  coordinate  $e^{\frac{1}{2}\ln 16} = e^{\ln 16 \frac{1}{2}} = 16^{\frac{1}{2}} = 4$

P has  $y$  coordinate  $e^{\frac{1}{2}\ln 4} = e^{\ln 4 \frac{1}{2}} = 4^{\frac{1}{2}} = 2$

Gradient of the line PQ =  $\frac{\text{change in } y}{\text{change in } x} = \frac{4 - 2}{\ln 16 - \ln 4} = \frac{2}{\ln \frac{16}{4}} = \frac{2}{\ln 4}$

Using  $y = mx + c$  the equation of the line PQ is

$$y = \frac{2}{\ln 4}x + c$$

$(\ln 4, 2)$  lies on line so

$$2 = \frac{2}{\ln 4} \times \ln 4 + c$$

$$2 = 2 + c$$

$$c = 0$$

$$\text{Equation of PQ is } y = \frac{2x}{\ln 4}$$

(b) The line passes through the origin as  $c = 0$ .

(c) Length from  $(\ln 4, 2)$  to  $(\ln 16, 4)$  is

$$\sqrt{(\ln 16 - \ln 4)^2 + 4 - 2)^2} = \sqrt{\left(\ln \frac{16}{4}\right)^2 + 2^2} = \sqrt{(\ln 4) + 4} = 2.43$$

# Solutionbank

## Edexcel AS and A Level Modular Mathematics

### Exercise C, Question 8

#### Question:

The functions  $f$  and  $g$  are defined over the set of real numbers by

$$f : x \rightarrow 3x - 5$$

$$g : x \rightarrow e^{-2x}$$

(a) State the range of  $g(x)$ .

(b) Sketch the graphs of the inverse functions  $f^{-1}$  and  $g^{-1}$  and write on your sketches the coordinates of any points at which a graph meets the coordinate axes.

(c) State, giving a reason, the number of roots of the equation

$$f^{-1}(x) = g^{-1}(x).$$

(d) Evaluate  $fg\left(-\frac{1}{3}\right)$ , giving your answer to 2 decimal places.

#### Solution:

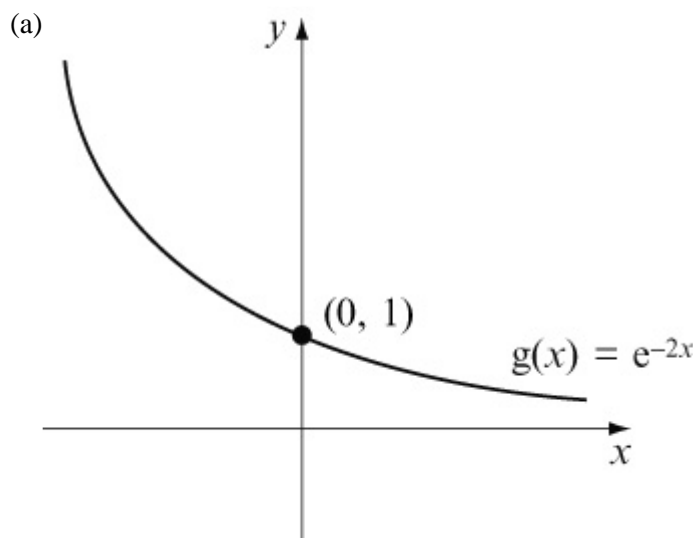

$$g(x) > 0$$

$$(b) f^{-1}(x) = \frac{x+5}{3}$$

$$g^{-1}(x) = -\frac{1}{2} \ln x$$

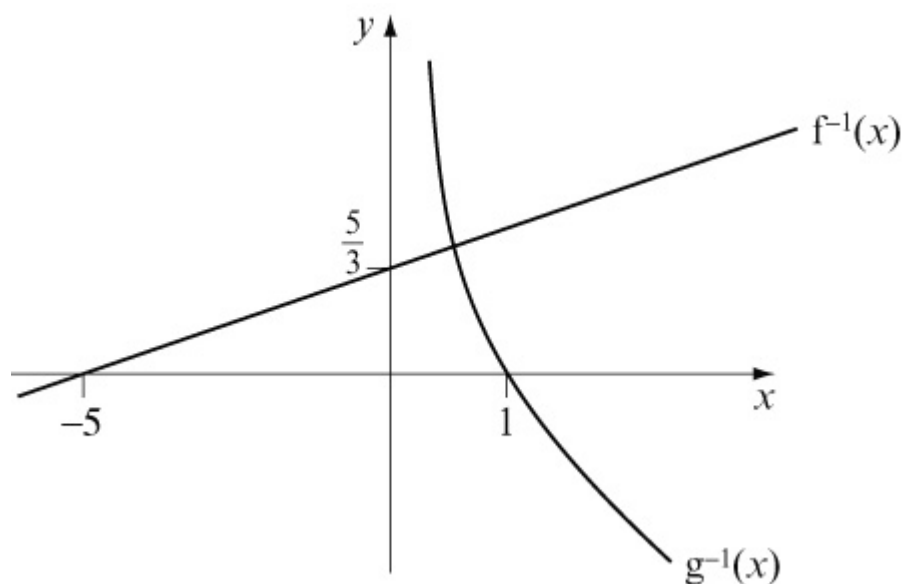

(c)  $f^{-1}(x) = g^{-1}(x)$  would have 1 root because there is 1 point of intersection.

$$(d) fg\left(-\frac{1}{3}\right) = f\left(e^{-2 \times -\frac{1}{3}}\right) = f\left(e^{\frac{2}{3}}\right) = 3 \times e^{\frac{2}{3}} - 5 = 0.84$$



# Solutionbank

## Edexcel AS and A Level Modular Mathematics

### Exercise C, Question 9

#### Question:

The function  $f$  is defined by  $f : x \rightarrow e^x + k$ ,  $x \in \mathbb{R}$  and  $k$  is a positive constant.

(a) State the range of  $f(x)$ .

(b) Find  $f(\ln k)$ , simplifying your answer.

(c) Find  $f^{-1}$ , the inverse function of  $f$ , in the form  $f^{-1} : x \rightarrow \dots$ , stating its domain.

(d) On the same axes, sketch the curves with equations  $y = f(x)$  and  $y = f^{-1}(x)$ , giving the coordinates of all points where the graphs cut the axes.

[E]

#### Solution:

(a)  $f : x \rightarrow e^x + k$

As  $x \rightarrow -\infty$ ,  $f(x) \rightarrow 0 + k = k$

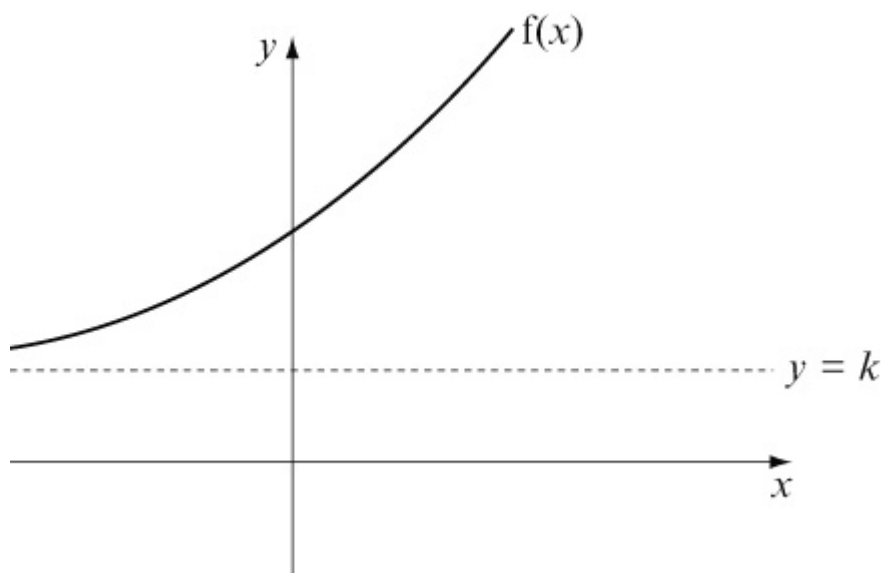

Range of  $f(x)$  is  $f(x) > k$

(b)  $f(\ln k) = e^{\ln k} + k = k + k = 2k$

(c) Let  $y = e^x + k$

$$y - k = e^x$$

$$\ln (y - k) = x$$

Hence  $f^{-1} : x \rightarrow \ln (x - k) , x > k$

(d)

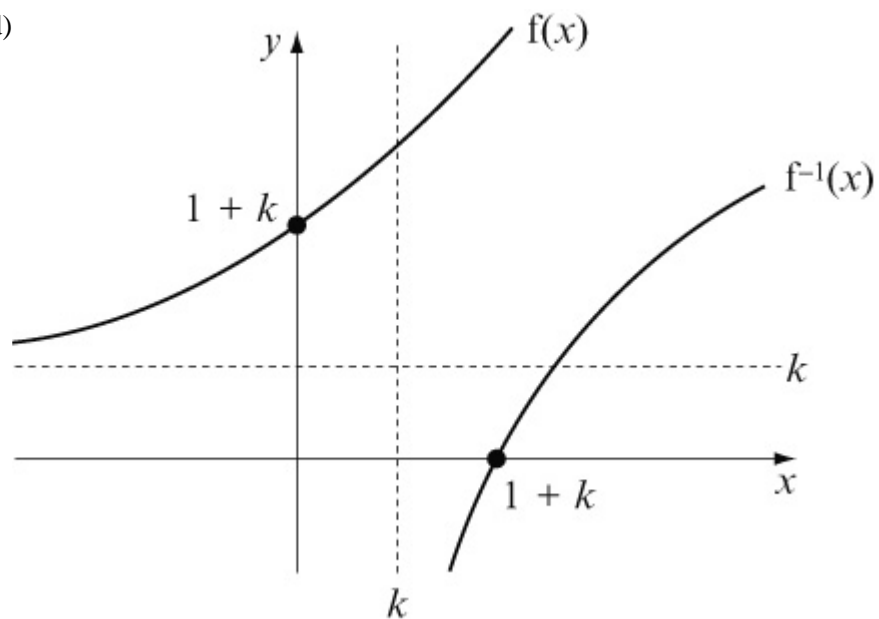

© Pearson Education Ltd 2008

# Solutionbank

## Edexcel AS and A Level Modular Mathematics

Exercise C, Question 10

### Question:

The function  $f$  is given by

$$f : x \rightarrow \ln(4 - 2x) \quad \{ x \in \mathbb{R}, x < 2 \}$$

(a) Find an expression for  $f^{-1}(x)$ .

(b) Sketch the curve with equation  $y = f^{-1}(x)$ , showing the coordinates of the points where the curve meets the axes.

(c) State the range of  $f^{-1}(x)$ .

The function  $g$  is given by

$$g : x \rightarrow e^x \quad \{ x \in \mathbb{R} \}$$

(d) Find the value of  $gf(0.5)$ .

[E]

### Solution:

$$f(x) = \ln(4 - 2x) \quad \{ x \in \mathbb{R}, x < 2 \}$$

(a) Let  $y = \ln(4 - 2x)$  and change the subject of the formula.

$$e^y = 4 - 2x$$

$$2x = 4 - e^y$$

$$x = \frac{4 - e^y}{2}$$

$$f^{-1} : x \rightarrow \frac{4 - e^x}{2} \quad \{ x \in \mathbb{R} \}$$

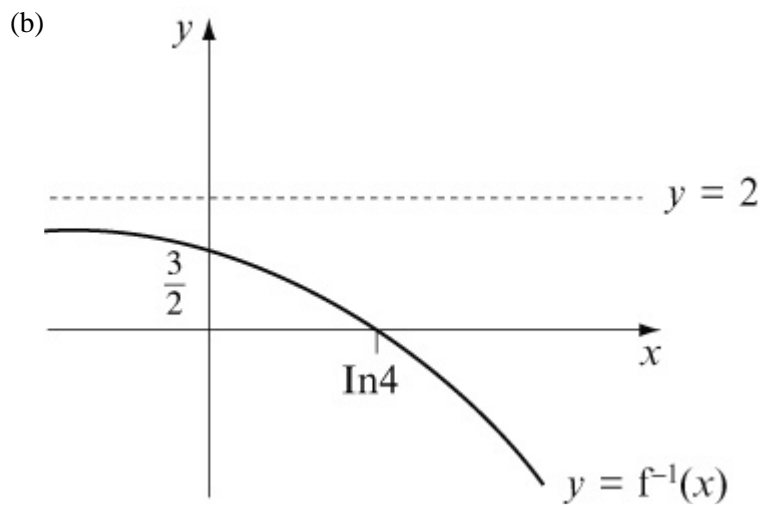

$$x = 0 \Rightarrow f^{-1}(x) = \frac{4-1}{2} = \frac{3}{2}$$

$$y = 0 \Rightarrow \frac{4-e^x}{2} = 0 \Rightarrow e^x = 4 \Rightarrow x = \ln 4$$

$$x \rightarrow \infty, y \rightarrow -\infty$$

$$x \rightarrow -\infty, y \rightarrow \frac{4-0}{2} = 2$$

(c) Range of  $f^{-1}(x)$  is  $f^{-1}(x) < 2$

$$(d) gf(0.5) = g[\ln(4 - 2 \times 0.5)] = g(\ln 3) = e^{\ln 3} = 3$$

# Solutionbank

## Edexcel AS and A Level Modular Mathematics

### Exercise C, Question 11

#### Question:

The function  $f(x)$  is defined by

$$f(x) = 3x^3 - 4x^2 - 5x + 2$$

(a) Show that  $(x + 1)$  is a factor of  $f(x)$ .

(b) Factorise  $f(x)$  completely.

(c) Solve, giving your answers to 2 decimal places, the equation

$$3[\ln(2x)]^3 - 4[\ln(2x)]^2 - 5\ln(2x) + 2 = 0 \quad x > 0$$

[E]

#### Solution:

$$f(x) = 3x^3 - 4x^2 - 5x + 2$$

$$\begin{aligned} \text{(a) } f(-1) &= 3 \times (-1)^3 - 4 \times (-1)^2 - 5 \times (-1) \\ &+ 2 = -3 - 4 + 5 + 2 = 0 \end{aligned}$$

As  $f(-1) = 0$  then  $(x + 1)$  is a factor.

$$\text{(b) } f(x) = 3x^3 - 4x^2 - 5x + 2$$

$$f(x) = (x + 1)(3x^2 - 7x + 2) \quad (\text{by inspection})$$

$$f(x) = (x + 1)(3x - 1)(x - 2)$$

$$\text{(c) If } 3[\ln(2x)]^3 - 4[\ln(2x)]^2 - 5[\ln(2x)] + 2 = 0$$

$$\Rightarrow [\ln(2x) + 1][3\ln(2x) - 1][\ln(2x) - 2] = 0$$

$$\Rightarrow \ln(2x) = -1, \frac{1}{3}, 2$$

$$\Rightarrow 2x = e^{-1}, e^{\frac{1}{3}}, e^2$$

$$\Rightarrow x = \frac{1}{2}e^{-1}, \frac{1}{2}e^{\frac{1}{3}}, \frac{1}{2}e^2$$

$$\Rightarrow x = 0.18, 0.70, 3.69$$

# Solutionbank

## Edexcel AS and A Level Modular Mathematics

### Exercise A, Question 1

#### Question:

Show that each of these equations  $f(x) = 0$  has a root in the given interval(s):

(a)  $x^3 - x + 5 = 0$      $-2 < x < -1$ .

(b)  $3 + x^2 - x^3 = 0$      $1 < x < 2$ .

(c)  $x^2 - \sqrt{x} - 10 = 0$      $3 < x < 4$ .

(d)  $x^3 - \frac{1}{x} - 2 = 0$      $-0.5 < x < -0.2$  and  $1 < x < 2$ .

(e)  $x^5 - 5x^3 - 10 = 0$      $-2 < x < -1.8$ ,  $-1.8 < x < -1$  and  $2 < x < 3$ .

(f)  $\sin x - \ln x = 0$      $2.2 < x < 2.3$

(g)  $e^x - \ln x - 5 = 0$      $1.65 < x < 1.75$ .

(h)  $\sqrt[3]{x} - \cos x = 0$      $0.5 < x < 0.6$ .

#### Solution:

(a) Let  $f(x) = x^3 - x + 5$

$$f(-2) = (-2)^3 - (-2) + 5 = -8 + 2 + 5 = -1$$

$$f(-1) = (-1)^3 - (-1) + 5 = -1 + 1 + 5 = 5$$

$f(-2) < 0$  and  $f(-1) > 0$  so there is a change of sign.

$\Rightarrow$  There is a root between  $x = -2$  and  $x = -1$ .

(b) Let  $f(x) = 3 + x^2 - x^3$

$$f(1) = 3 + (1)^2 - (1)^3 = 3 + 1 - 1 = 3$$

$$f(2) = 3 + (2)^2 - (2)^3 = 3 + 4 - 8 = -1$$

$f(1) > 0$  and  $f(2) < 0$  so there is a change of sign.

$\Rightarrow$  There is a root between  $x = 1$  and  $x = 2$ .

(c) Let  $f(x) = x^2 - \sqrt{x} - 10$

$$f(3) = 3^2 - \sqrt{3} - 10 = -2.73$$

$$f(4) = 4^2 - \sqrt{4} - 10 = 4$$

$f(3) < 0$  and  $f(4) > 0$  so there is a change of sign.

$\Rightarrow$  There is a root between  $x = 3$  and  $x = 4$ .

(d) Let  $f(x) = x^3 - \frac{1}{x} - 2$

$$\text{[1]} \quad f(-0.5) = (-0.5)^3 - \frac{1}{-0.5} - 2 = -0.125$$

$$f(-0.2) = (-0.2)^3 - \frac{1}{-0.2} - 2 = 2.992$$

$f(-0.5) < 0$  and  $f(-0.2) > 0$  so there is a change of sign.

$\Rightarrow$  There is a root between  $x = -0.5$  and  $x = -0.2$ .

$$\text{[2]} \quad f(1) = (1)^3 - \frac{1}{1} - 2 = -2$$

$$f(2) = (2)^3 - \frac{1}{2} - 2 = 5\frac{1}{2}$$

$f(1) < 0$  and  $f(2) > 0$  so there is a change of sign.

$\Rightarrow$  There is a root between  $x = 1$  and  $x = 2$ .

(e) Let  $f(x) = x^5 - 5x^3 - 10$

$$\text{[1]} \quad f(-2) = (-2)^5 - 5(-2)^3 - 10 = -2$$

$$f(-1.8) = (-1.8)^5 - 5(-1.8)^3 - 10 = 0.26432$$

$f(-2) < 0$  and  $f(-1.8) > 0$  so there is a change of sign.

$\Rightarrow$  There is a root between  $x = -2$  and  $x = -1.8$ .

$$\text{[2]} \quad f(-1.8) = 0.26432$$

$$f(-1) = (-1)^5 - 5(-1)^3 - 10 = -6$$

$f(-1.8) > 0$  and  $f(-1) < 0$  so there is a change of sign.

$\Rightarrow$  There is a root between  $x = -1.8$  and  $x = -1$ .

$$\text{[3]} \quad f(2) = (2)^5 - 5(2)^3 - 10 = -18$$

$$f(3) = (3)^5 - 5(3)^3 - 10 = 98$$

$f(2) < 0$  and  $f(3) > 0$  so there is a change of sign.

$\Rightarrow$  There is a root between  $x = 2$  and  $x = 3$ .

(f) Let  $f(x) = \sin x - \ln x$

$$f(2.2) = \sin 2.2 - \ln 2.2 = 0.0200$$

$$f(2.3) = -0.0872$$

$f(2.2) > 0$  and  $f(2.3) < 0$  so there is a change of sign.

⇒ There is a root between  $x = 2.2$  and  $x = 2.3$ .

(g) Let  $f(x) = e^x - \ln x - 5$

$$f(1.65) = e^{1.65} - \ln 1.65 - 5 = -0.294$$

$$f(1.75) = e^{1.75} - \ln 1.75 - 5 = 0.195$$

$f(1.65) < 0$  and  $f(1.75) > 0$  so there is a change of sign.

⇒ There is a root between  $x = 1.65$  and  $x = 1.75$ .

(h) Let  $f(x) = \sqrt[3]{x} - \cos x$

$$f(0.5) = \sqrt[3]{0.5} - \cos 0.5 = -0.0839$$

$$f(0.6) = \sqrt[3]{0.6} - \cos 0.6 = 0.0181$$

$f(0.5) < 0$  and  $f(0.6) > 0$  so there is a change of sign.

⇒ There is a root between  $x = 0.5$  and  $x = 0.6$ .



# Solutionbank

## Edexcel AS and A Level Modular Mathematics

Exercise A, Question 2

### Question:

Given that  $f(x) = x^3 - 5x^2 + 2$ , show that the equation  $f(x) = 0$  has a root near to  $x = 5$ .

### Solution:

$$\text{Let } f(x) = x^3 - 5x^2 + 2$$

$$f(4.9) = (4.9)^3 - 5(4.9)^2 + 2 = -0.401$$

$$f(5.0) = 2$$

$f(4.9) < 0$  and  $f(5) > 0$  so there is a change of sign.

$\Rightarrow$  There is a root between  $x = 4.9$  and  $x = 5$ .

© Pearson Education Ltd 2008

# Solutionbank

## Edexcel AS and A Level Modular Mathematics

Exercise A, Question 3

### Question:

Given that  $f(x) \equiv 3 - 5x + x^3$ , show that the equation  $f(x) = 0$  has a root  $x = a$ , where  $a$  lies in the interval  $1 < a < 2$ .

### Solution:

$$\text{Let } f(x) = 3 - 5x + x^3$$

$$f(1) = 3 - 5(1) + (1)^3 = -1$$

$$f(2) = 3 - 5(2) + (2)^3 = 1$$

$f(1) < 0$  and  $f(2) > 0$  so there is a change of sign.

$\Rightarrow$  There is a root between  $x = 1$  and  $x = 2$ .

So if the root is  $x = a$ , then  $1 < a < 2$ .

© Pearson Education Ltd 2008

# Solutionbank

## Edexcel AS and A Level Modular Mathematics

Exercise A, Question 4

### Question:

Given that  $f(x) \equiv e^x \sin x - 1$ , show that the equation  $f(x) = 0$  has a root  $x = r$ , where  $r$  lies in the interval  $0.5 < r < 0.6$ .

### Solution:

$$f(x) = e^x \sin x - 1$$

$$f(0.5) = e^{0.5} \sin 0.5 - 1 = -0.210$$

$$f(0.6) = e^{0.6} \sin 0.6 - 1 = 0.0288$$

$f(0.5) < 0$  and  $f(0.6) > 0$  so there is a change of sign.

$\Rightarrow$  There is a root between  $x = 0.5$  and  $x = 0.6$ .

So if the root is  $x = r$ , then  $0.5 < r < 0.6$ .

© Pearson Education Ltd 2008

# Solutionbank

## Edexcel AS and A Level Modular Mathematics

Exercise A, Question 5

### Question:

It is given that  $f(x) \equiv x^3 - 7x + 5$ .

(a) Copy and complete the table below.

$x$	-3	-2	-1	0	1	2	3
$f(x)$							

(b) Given that the negative root of the equation  $x^3 - 7x + 5 = 0$  lies between  $\alpha$  and  $\alpha + 1$ , where  $\alpha$  is an integer, write down the value of  $\alpha$ .

### Solution:

(a)

$x$	-3	-2	-1	0	1	2	3
$f(x)$	-1	11	11	5	-1	-1	11

(b)  $f(-3) < 0$  and  $f(-2) > 0$  so there is a change of sign.

$\Rightarrow$  There is a root between  $x = -3$  and  $x = -2$ .

So  $\alpha = -3$ . (**Note.**  $\alpha + 1 = -2$ ).

# Solutionbank

## Edexcel AS and A Level Modular Mathematics

### Exercise A, Question 6

#### Question:

Given that  $f(x) \equiv x - (\sin x + \cos x)^{\frac{1}{2}}$ ,  $0 \leq x \leq \frac{3}{4}\pi$ , show that the equation  $f(x) = 0$  has a root lying between  $\frac{\pi}{3}$  and  $\frac{\pi}{2}$ .

#### Solution:

$$f(x) = x - (\sin x + \cos x)^{\frac{1}{2}}$$

$$f\left(\frac{\pi}{3}\right) = \frac{\pi}{3} - \left(\sin \frac{\pi}{3} + \cos \frac{\pi}{3}\right)^{\frac{1}{2}} = -0.122$$

$$f\left(\frac{\pi}{2}\right) = \frac{\pi}{2} - \left(\sin \frac{\pi}{2} + \cos \frac{\pi}{2}\right)^{\frac{1}{2}} = 0.571$$

$$f\left(\frac{\pi}{3}\right) < 0 \text{ and } f\left(\frac{\pi}{2}\right) > 0 \text{ so there is a change of sign.}$$

$$\Rightarrow \text{There is a root between } x = \frac{\pi}{3} \text{ and } x = \frac{\pi}{2}.$$

# Solutionbank

## Edexcel AS and A Level Modular Mathematics

### Exercise A, Question 7

#### Question:

- (a) Using the same axes, sketch the graphs of  $y = e^{-x}$  and  $y = x^2$ .
- (b) Explain why the equation  $e^{-x} = x^2$  has only one root.
- (c) Show that the equation  $e^{-x} = x^2$  has a root between  $x = 0.70$  and  $x = 0.71$ .

#### Solution:

(a)

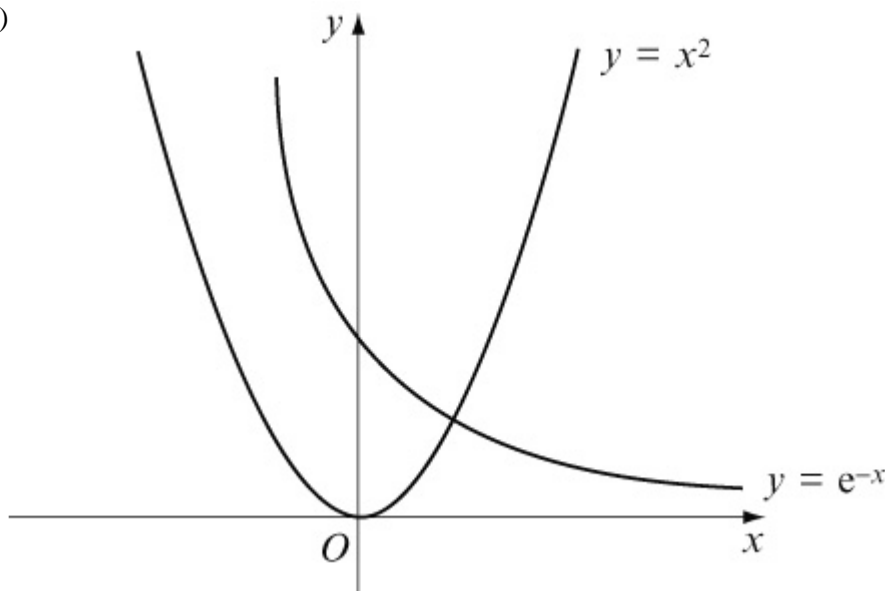

- (b) The curves meet where  $e^{-x} = x^2$   
 The curves meet at one point, so there is one value of  $x$  that satisfies the equation  $e^{-x} = x^2$ .  
 So  $e^{-x} = x^2$  has one root.

- (c) Let  $f(x) = e^{-x} - x^2$   
 $f(0.70) = e^{-0.70} - 0.70^2 = 0.00659$   
 $f(0.71) = e^{-0.71} - 0.71^2 = -0.0125$   
 $f(0.70) > 0$  and  $f(0.71) < 0$  so there is a change of sign.  
 $\Rightarrow$  There is a root between  $x = 0.70$  and  $x = 0.71$ .

# Solutionbank

## Edexcel AS and A Level Modular Mathematics

Exercise A, Question 8

### Question:

- (a) On the same axes, sketch the graphs of  $y = \ln x$  and  $y = e^x - 4$ .
- (b) Write down the number of roots of the equation  $\ln x = e^x - 4$ .
- (c) Show that the equation  $\ln x = e^x - 4$  has a root in the interval  $(1.4, 1.5)$ .

### Solution:

(a)

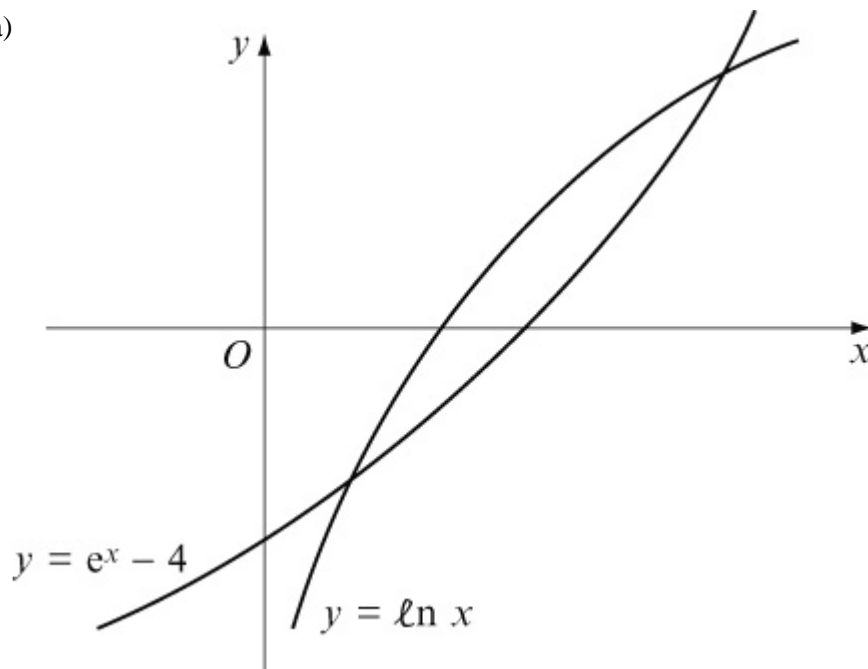

(b) The curves meet at two points, so there are two values of  $x$  that satisfy the equation  $\ln x = e^x - 4$ .

So  $\ln x = e^x - 4$  has two roots.

(c) Let  $f(x) = \ln x - e^x + 4$

$$f(1.4) = \ln 1.4 - e^{1.4} + 4 = 0.281$$

$$f(1.5) = \ln 1.5 - e^{1.5} + 4 = -0.0762$$

$f(1.4) > 0$  and  $f(1.5) < 0$  so there is a change of sign.

$\Rightarrow$  There is a root between  $x = 1.4$  and  $x = 1.5$ .

# Solutionbank

## Edexcel AS and A Level Modular Mathematics

### Exercise A, Question 9

#### Question:

- (a) On the same axes, sketch the graphs of  $y = \sqrt{x}$  and  $y = \frac{2}{x}$ .
- (b) Using your sketch, write down the number of roots of the equation  $\sqrt{x} = \frac{2}{x}$ .
- (c) Given that  $f(x) \equiv \sqrt{x} - \frac{2}{x}$ , show that  $f(x) = 0$  has a root  $r$ , where  $r$  lies between  $x = 1$  and  $x = 2$ .
- (d) Show that the equation  $\sqrt{x} = \frac{2}{x}$  may be written in the form  $x^p = q$ , where  $p$  and  $q$  are integers to be found.
- (e) Hence write down the exact value of the root of the equation  $\sqrt{x} - \frac{2}{x} = 0$ .

#### Solution:

(a)

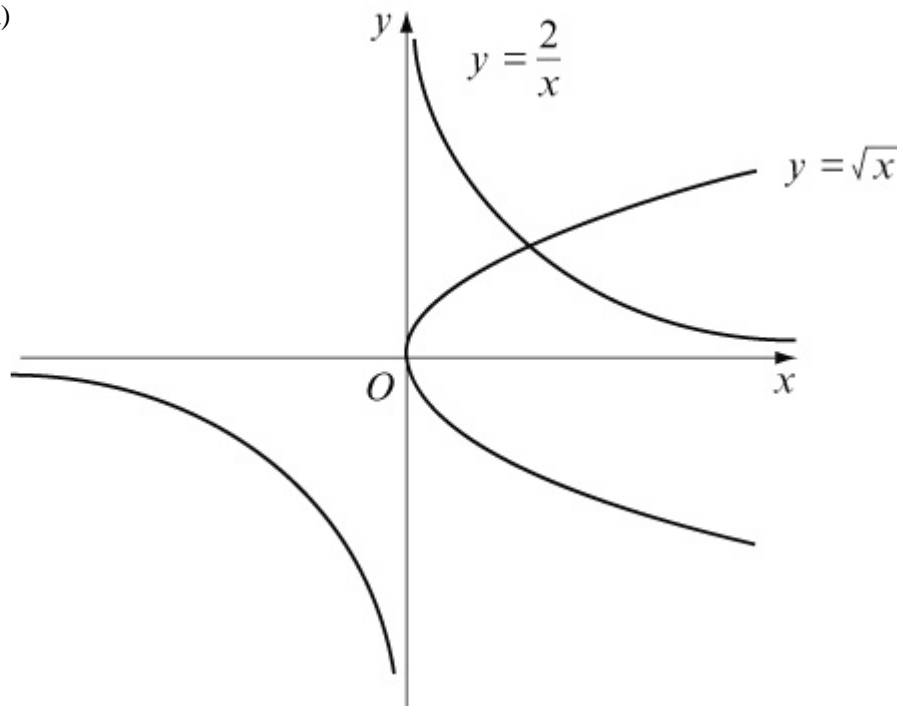

- (b) The curves meet at one point, so there is one value of  $x$  that satisfies the



equation  $\sqrt{x} = \frac{2}{x}$ .

So  $\sqrt{x} = \frac{2}{x}$  has **one** root.

(c)  $f(x) = \sqrt{x} - \frac{2}{x}$

$$f(1) = \sqrt{1} - \frac{2}{1} = -1$$

$$f(2) = \sqrt{2} - \frac{2}{2} = 0.414$$

$f(1) < 0$  and  $f(2) > 0$  so there is a change of sign.

$\Rightarrow$  There is a root between  $x = 1$  and  $x = 2$ .

(d)  $\sqrt{x} = \frac{2}{x}$

$$x^{\frac{1}{2}} = \frac{2}{x}$$

$$x^{\frac{1}{2}} \times x = 2$$

$$x^{\frac{1}{2} + 1} = 2$$

$$x^{\frac{3}{2}} = 2$$

$$\left(x^{\frac{3}{2}}\right)^2 = 2^2$$

$$x^3 = 4$$

So  $p = 3$  and  $q = 4$

(e)  $x^{\frac{3}{2}} = 2$

$$\Rightarrow x = 2^{\frac{2}{3}} \quad \left[ = \left(2^2\right)^{\frac{1}{3}} = 4^{\frac{1}{3}} \right]$$

# Solutionbank

## Edexcel AS and A Level Modular Mathematics

Exercise A, Question 10

### Question:

- (a) On the same axes, sketch the graphs of  $y = \frac{1}{x}$  and  $y = x + 3$ .
- (b) Write down the number of roots of the equation  $\frac{1}{x} = x + 3$ .
- (c) Show that the positive root of the equation  $\frac{1}{x} = x + 3$  lies in the interval (0.30, 0.31).
- (d) Show that the equation  $\frac{1}{x} = x + 3$  may be written in the form  $x^2 + 3x - 1 = 0$ .
- (e) Use the quadratic formula to find the positive root of the equation  $x^2 + 3x - 1 = 0$  to 3 decimal places.

### Solution:

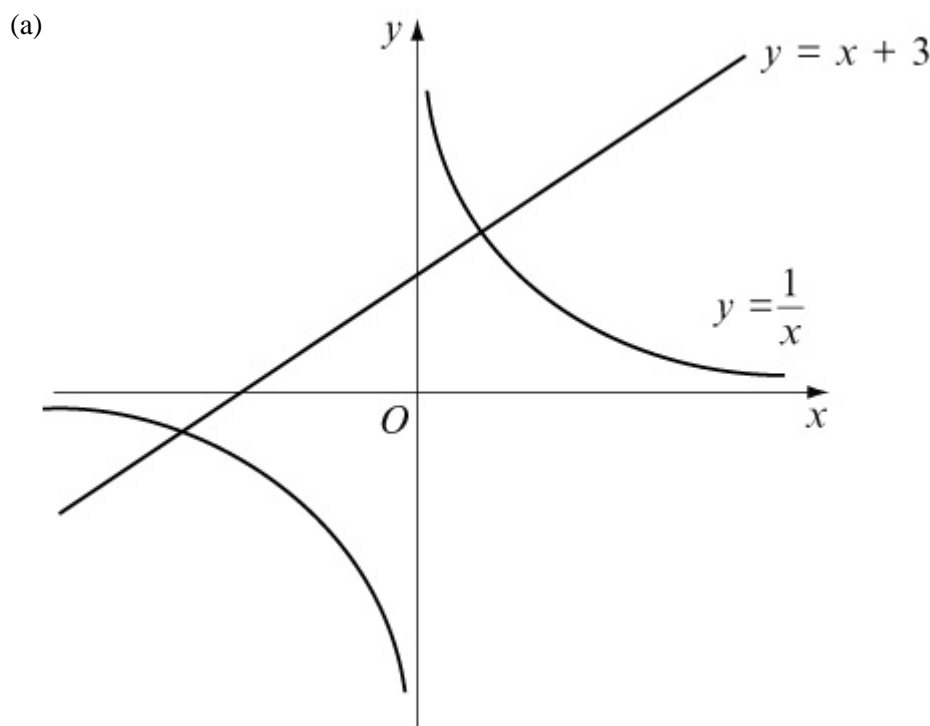

- (b) The line meets the curve at two points, so there are two values of  $x$  that satisfy the equation  $\frac{1}{x} = x + 3$ .

So  $\frac{1}{x} = x + 3$  has **two** roots.

(c) Let  $f(x) = \frac{1}{x} - x - 3$

$$f(0.30) = \frac{1}{0.30} - (0.30) - 3 = 0.0333$$

$$f(0.31) = \frac{1}{0.31} - (0.31) - 3 = -0.0842$$

$f(0.30) > 0$  and  $f(0.31) < 0$  so there is a change of sign.

$\Rightarrow$  There is a root between  $x = 0.30$  and  $x = 0.31$ .

(d)  $\frac{1}{x} = x + 3$

$$\frac{1}{x} \times x = x \times x + 3 \times x \quad (\times x)$$

$$1 = x^2 + 3x$$

$$\text{So } x^2 + 3x - 1 = 0$$

(e) Using  $x = \frac{-b \pm \sqrt{b^2 - 4ac}}{2a}$  with  $a = 1$ ,  $b = 3$ ,  $c = -1$

$$x = \frac{-(3) \pm \sqrt{(3)^2 - 4(1)(-1)}}{2(1)} = \frac{-3 \pm \sqrt{9+4}}{2} = \frac{-3 \pm \sqrt{13}}{2}$$

$$\text{So } x = \frac{-3 + \sqrt{13}}{2} = 0.303$$

$$\text{and } x = \frac{-3 - \sqrt{13}}{2} = -3.303$$

The positive root is 0.303 to 3 decimal places.

# Solutionbank

## Edexcel AS and A Level Modular Mathematics

### Exercise B, Question 1

#### Question:

Show that  $x^2 - 6x + 2 = 0$  can be written in the form:

$$(a) x = \frac{x^2 + 2}{6}$$

$$(b) x = \sqrt{6x - 2}$$

$$(c) x = 6 - \frac{2}{x}$$

#### Solution:

$$(a) x^2 - 6x + 2 = 0$$

$$6x = x^2 + 2 \quad \text{Add } 6x \text{ to each side}$$

$$x = \frac{x^2 + 2}{6} \quad \text{Divide each side by } 6$$

$$(b) x^2 - 6x + 2 = 0$$

$$x^2 + 2 = 6x \quad \text{Add } 6x \text{ to each side}$$

$$x^2 = 6x - 2 \quad \text{Subtract } 2 \text{ from each side}$$

$$x = \sqrt{6x - 2} \quad \text{Take the square root of each side}$$

$$(c) x^2 - 6x + 2 = 0$$

$$x^2 + 2 = 6x \quad \text{Add } 6x \text{ to each side}$$

$$x^2 = 6x - 2 \quad \text{Subtract } 2 \text{ from each side}$$

$$\frac{x^2}{x} = \frac{6x}{x} - \frac{2}{x} \quad \text{Divide each term by } x$$

$$x = 6 - \frac{2}{x} \quad \text{Simplify}$$

# Solutionbank

## Edexcel AS and A Level Modular Mathematics

### Exercise B, Question 2

#### Question:

Show that  $x^3 + 5x^2 - 2 = 0$  can be written in the form:

$$(a) x = \sqrt[3]{2 - 5x^2}$$

$$(b) x = \frac{2}{x^2} - 5$$

$$(c) x = \sqrt{\frac{2 - x^3}{5}}$$

#### Solution:

$$(a) x^3 + 5x^2 - 2 = 0$$

$$x^3 + 5x^2 = 2 \quad \text{Add 2 to each side}$$

$$x^3 = 2 - 5x^2 \quad \text{Subtract } 5x^2 \text{ from each side}$$

$$x = \sqrt[3]{2 - 5x^2} \quad \text{Take the cube root of each side}$$

$$(b) x^3 + 5x^2 - 2 = 0$$

$$x^3 + 5x^2 = 2 \quad \text{Add 2 to each side}$$

$$x^3 = 2 - 5x^2 \quad \text{Subtract } 5x^2 \text{ from each side}$$

$$\frac{x^3}{x^2} = \frac{2}{x^2} - \frac{5x^2}{x^2} \quad \text{Divide each term by } x^2$$

$$x = \frac{2}{x^2} - 5 \quad \text{Simplify}$$

$$(c) x^3 + 5x^2 - 2 = 0$$

$$x^3 + 5x^2 = 2 \quad \text{Add 2 to each side}$$

$$5x^2 = 2 - x^3 \quad \text{Subtract } x^3 \text{ from each side}$$

$$x^2 = \frac{2 - x^3}{5} \quad \text{Divide each side by 5}$$

$$x = \sqrt{\frac{2 - x^3}{5}} \quad \text{Take the square root of each side}$$



# Solutionbank

## Edexcel AS and A Level Modular Mathematics

### Exercise B, Question 3

#### Question:

Rearrange  $x^3 - 3x + 4 = 0$  into the form  $x = \frac{x^3}{3} + a$ , where the value of  $a$  is to be found.

#### Solution:

$$x^3 - 3x + 4 = 0$$

$$3x = x^3 + 4 \quad \text{Add } 3x \text{ to each side}$$

$$\frac{3x}{3} = \frac{x^3}{3} + \frac{4}{3} \quad \text{Divide each term by 3}$$

$$x = \frac{x^3}{3} + \frac{4}{3} \quad \text{Simplify}$$

$$\text{So } a = \frac{4}{3}$$

# Solutionbank

## Edexcel AS and A Level Modular Mathematics

### Exercise B, Question 4

#### Question:

Rearrange  $x^4 - 3x^3 - 6 = 0$  into the form  $x = \sqrt[3]{px^4 - 2}$ , where the value of  $p$  is to be found.

#### Solution:

$$x^4 - 3x^3 - 6 = 0$$

$$3x^3 = x^4 - 6 \quad \text{Add } 3x^3 \text{ to each side}$$

$$\frac{3x^3}{3} = \frac{x^4}{3} - \frac{6}{3} \quad \text{Divide each term by 3}$$

$$x^3 = \frac{x^4}{3} - 2 \quad \text{Simplify}$$

$$x = \sqrt[3]{\frac{x^4}{3} - 2} \quad \text{Take the cube root of each side}$$

$$\text{So } p = \frac{1}{3}$$



# Solutionbank

## Edexcel AS and A Level Modular Mathematics

### Exercise B, Question 5

#### Question:

(a) Show that the equation  $x^3 - x^2 + 7 = 0$  can be written in the form  $x = \sqrt[3]{x^2 - 7}$ .

(b) Use the iteration formula  $x_{n+1} = x_n^2 - 7$ , starting with  $x_0 = 1$ , to find  $x_2$  to 1 decimal place.

#### Solution:

$$(a) x^3 - x^2 + 7 = 0$$

$$x^3 + 7 = x^2 \quad \text{Add } x^2 \text{ to each side}$$

$$x^3 = x^2 - 7 \quad \text{Subtract 7 from each side}$$

$$x = \sqrt[3]{x^2 - 7} \quad \text{Take the cube root of each side}$$

$$(b) x_0 = 1$$

$$x_1 = \sqrt[3]{(1)^2 - 7} = -1.817\dots$$

$$x_2 = \sqrt[3]{(-1.817\dots)^2 - 7} = -1.546\dots$$

$$\text{So } x_2 = -1.5 \text{ (1 d.p.)}$$

# Solutionbank

## Edexcel AS and A Level Modular Mathematics

### Exercise B, Question 6

#### Question:

(a) Show that the equation  $x^3 + 3x^2 - 5 = 0$  can be written in the form  $x = \sqrt{\frac{5}{x+3}}$ .

(b) Use the iteration formula  $x_{n+1} = \sqrt{\frac{5}{x_n+3}}$ , starting with  $x_0 = 1$ , to find  $x_4$  to 3 decimal places.

#### Solution:

$$(a) x^3 + 3x^2 - 5 = 0$$

$$x^2(x+3) - 5 = 0 \quad \text{Factorise } x^2$$

$$x^2(x+3) = 5 \quad \text{Add 5 to each side}$$

$$x^2 = \frac{5}{x+3} \quad \text{Divide each side by } (x+3)$$

$$x = \sqrt{\frac{5}{x+3}} \quad \text{Take the square root of each side}$$

$$(b) x_0 = 1$$

$$x_1 = \sqrt{\frac{5}{(1)+3}} = 1.118\dots$$

$$x_2 = \sqrt{\frac{5}{(1.118\dots)+3}} = 1.101\dots$$

$$x_3 = \sqrt{\frac{5}{(1.101\dots)+3}} = 1.104\dots$$

$$x_4 = \sqrt{\frac{5}{(1.104\dots)+3}} = 1.103768\dots$$

$$\text{So } x_4 = 1.104 \text{ (3 d.p.)}$$

# Solutionbank

## Edexcel AS and A Level Modular Mathematics

### Exercise B, Question 7

#### Question:

(a) Show that the equation  $x^6 - 5x + 3 = 0$  has a root between  $x = 1$  and  $x = 1.5$ .

(b) Use the iteration formula  $x_{n+1} = \sqrt[5]{5 - \frac{3}{x_n}}$  to find an approximation for the root of the equation  $x^6 - 5x + 3 = 0$ , giving your answer to 2 decimal places.

#### Solution:

(a) Let  $f(x) = x^6 - 5x + 3$

$$f(1) = (1)^6 - 5(1) + 3 = -1$$

$$f(1.5) = (1.5)^6 - 5(1.5) + 3 = 6.89$$

$f(1) < 0$  and  $f(1.5) > 0$  so there is a change of sign.

$\Rightarrow$  There is a root between  $x = 1$  and  $x = 1.5$ .

(b)  $x_0 = 1$

$$x_1 = \sqrt[5]{5 - \frac{3}{1}} = 1.148\dots$$

Similarly,

$$x_2 = 1.190\dots$$

$$x_3 = 1.199\dots$$

$$x_4 = 1.200\dots$$

$$x_5 = 1.201\dots$$

So the root is 1.20 (2 d.p.)

# Solutionbank

## Edexcel AS and A Level Modular Mathematics

### Exercise B, Question 8

#### Question:

(a) Rearrange the equation  $x^2 - 6x + 1 = 0$  into the form  $x = p - \frac{1}{x}$ , where  $p$  is a constant to be found.

(b) Starting with  $x_0 = 3$ , use the iteration formula  $x_{n+1} = p - \frac{1}{x_n}$  with your value of  $p$ , to find  $x_3$  to 2 decimal places.

#### Solution:

$$(a) x^2 - 6x + 1 = 0$$

$$x^2 + 1 = 6x \quad \text{Add } 6x \text{ to each side}$$

$$x^2 = 6x - 1 \quad \text{Subtract 1 from each side}$$

$$\frac{x^2}{x} = \frac{6x}{x} - \frac{1}{x} \quad \text{Divide each term by } x$$

$$x = 6 - \frac{1}{x} \quad \text{Simplify}$$

$$\text{So } p = 6$$

$$(b) x_0 = 3$$

$$x_1 = 6 - \frac{1}{3} = 5.666\dots$$

$$x_2 = 6 - \frac{1}{5.666\dots} = 5.823\dots$$

$$x_3 = 6 - \frac{1}{5.823\dots} = 5.828\dots$$

$$\text{So } x_3 = 5.83 \text{ (2 d.p.)}$$

# Solutionbank

## Edexcel AS and A Level Modular Mathematics

### Exercise B, Question 9

#### Question:

(a) Show that the equation  $x^3 - x^2 + 8 = 0$  has a root in the interval  $(-2, -1)$ .

(b) Use a suitable iteration formula to find an approximation to 2 decimal places for the negative root of the equation  $x^3 - x^2 + 8 = 0$ .

#### Solution:

(a) Let  $f(x) = x^3 - x^2 + 8$

$$f(-2) = (-2)^3 - (-2)^2 + 8 = -8 - 4 + 8 = -4$$

$$f(-1) = (-1)^3 - (-1)^2 + 8 = -1 - 1 + 8 = 6$$

$f(-2) < 0$  and  $f(-1) > 0$  so there is a change of sign.

$\Rightarrow$  There is a root between  $x = -2$  and  $x = -1$ .

(b)  $x^3 - x^2 + 8 = 0$

$$x^3 + 8 = x^2 \quad \text{Add } x^2 \text{ to each side}$$

$$x^3 = x^2 - 8 \quad \text{Subtract 8 from each side}$$

$$x = \sqrt[3]{x^2 - 8} \quad \text{Take the cube root of each side}$$

Using  $x_{n+1} = \sqrt[3]{x_n^2 - 8}$  and any value for  $x_0$ , the root is  $-1.72$  (2 d.p.).

# Solutionbank

## Edexcel AS and A Level Modular Mathematics

### Exercise B, Question 10

#### Question:

- (a) Show that  $x^7 - 5x^2 - 20 = 0$  has a root in the interval (1.6, 1.7).
- (b) Use a suitable iteration formula to find an approximation to 3 decimal places for the root of  $x^7 - 5x^2 - 20 = 0$  in the interval (1.6, 1.7).

#### Solution:

- (a) Let  $f(x) = x^7 - 5x^2 - 20$
- $$f(1.6) = (1.6)^7 - 5(1.6)^2 - 20 = -5.96$$
- $$f(1.7) = (1.7)^7 - 5(1.7)^2 - 20 = 6.58$$
- $f(1.6) < 0$  and  $f(1.7) > 0$  so there is a change of sign.
- $\Rightarrow$  There is a root between  $x = 1.6$  and  $x = 1.7$ .

- (b)  $x^7 - 5x^2 - 20 = 0$
- $$x^7 - 20 = 5x^2 \quad \text{Add } 5x^2 \text{ to each side}$$
- $$x^7 = 5x^2 + 20 \quad \text{Add } 20 \text{ to each side}$$
- $$x = \sqrt[7]{5x^2 + 20} \quad \text{Take the seventh root of each side}$$
- So let  $x_{n+1} = \sqrt[7]{5x_n^2 + 20}$  and  $x_0 = 1.6$ , then
- $$x_1 = \sqrt[7]{5(1.6)^2 + 20} = 1.6464\dots$$

Similarly,

$$x_2 = 1.6518\dots$$

$$x_3 = 1.6524\dots$$

$$x_4 = 1.6525\dots$$

$$x_5 = 1.6525\dots$$

So the root is 1.653 (3 d.p.)

# Solutionbank

## Edexcel AS and A Level Modular Mathematics

### Exercise C, Question 1

#### Question:

(a) Rearrange the cubic equation  $x^3 - 6x - 2 = 0$  into the form  $x = \pm \sqrt{a + \frac{b}{x}}$ . State the values of the constants  $a$  and  $b$ .

(b) Use the iterative formula  $x_{n+1} = \sqrt{a + \frac{b}{x_n}}$  with  $x_0 = 2$  and your values of  $a$  and  $b$  to find the approximate positive solution  $x_4$  of the equation, to an appropriate degree of accuracy. Show all your intermediate answers.

[E]

#### Solution:

$$(a) x^3 - 6x - 2 = 0$$

$$x^3 - 2 = 6x \quad \text{Add } 6x \text{ to each side}$$

$$x^3 = 6x + 2 \quad \text{Add } 2 \text{ to each side}$$

$$\frac{x^3}{x} = \frac{6x}{x} + \frac{2}{x} \quad \text{Divide each term by } x$$

$$x^2 = 6 + \frac{2}{x} \quad \text{Simplify}$$

$$x = \sqrt{6 + \frac{2}{x}} \quad \text{Take the square root of each side}$$

So  $a = 6$  and  $b = 2$

$$(b) x_0 = 2$$

$$x_1 = \sqrt{6 + \frac{2}{2}} = \sqrt{7} = 2.64575\dots$$

$$x_2 = \sqrt{6 + \frac{2}{2.64575\dots}} = 2.59921\dots$$

$$x_3 = \sqrt{6 + \frac{2}{2.59921\dots}} = 2.60181\dots$$

$$x_4 = \sqrt{6 + \frac{2}{2.60181\dots}} = 2.60167\dots$$

So  $x_4 = 2.602$  (3 d.p.)





# Solutionbank

## Edexcel AS and A Level Modular Mathematics

Exercise C, Question 2

### Question:

(a) By sketching the curves with equations  $y = 4 - x^2$  and  $y = e^x$ , show that the equation  $x^2 + e^x - 4 = 0$  has one negative root and one positive root.

(b) Use the iteration formula  $x_{n+1} = - (4 - e^{x_n})^{\frac{1}{2}}$  with  $x_0 = -2$  to find in turn  $x_1, x_2, x_3$  and  $x_4$  and hence write down an approximation to the negative root of the equation, giving your answer to 4 decimal places.  
An attempt to evaluate the positive root of the equation is made using the iteration formula

$$x_{n+1} = (4 - e^{x_n})^{\frac{1}{2}} \text{ with } x_0 = 1.3.$$

(c) Describe the result of such an attempt.

[E]

### Solution:

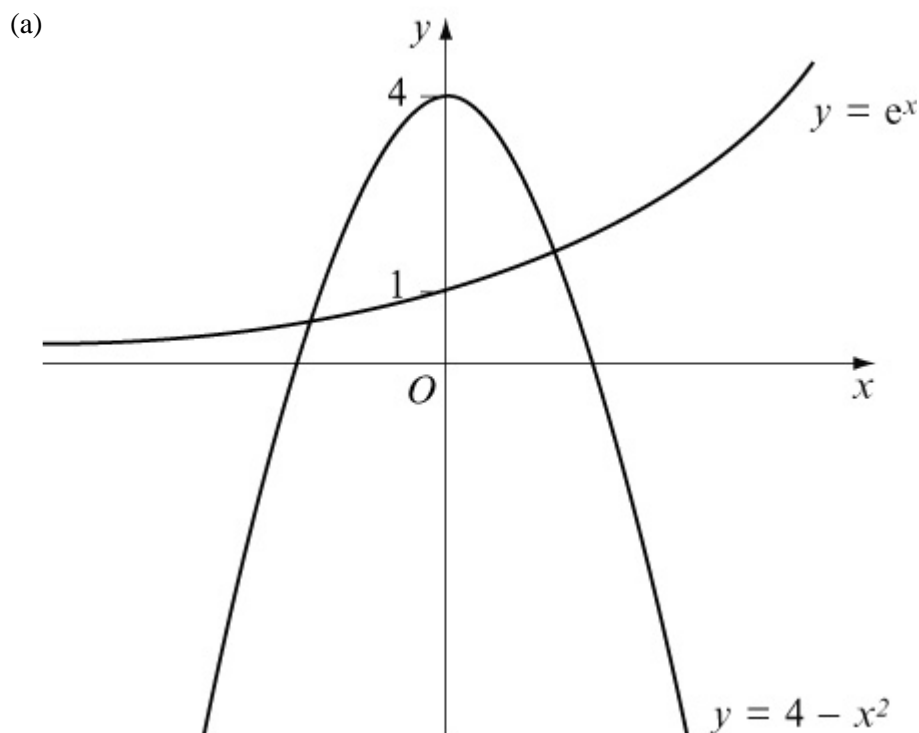

The curves meet when  $x < 0$  and  $x > 0$ , so the equation  $e^x = 4 - x^2$  has one negative and one positive root.

(Note that  $e^x = 4 - x^2$  is the same as  $x^2 + e^x - 4 = 0$ ).

$$(b) x_0 = -2$$

$$x_1 = - (4 - e^{-2})^{\frac{1}{2}} = -1.965875051$$

$$x_2 = - (4 - e^{-1.965875051})^{\frac{1}{2}} = -1.964679797$$

$$x_3 = - (4 - e^{-1.964679797})^{\frac{1}{2}} = -1.964637175$$

$$x_4 = - (4 - e^{-1.964637175})^{\frac{1}{2}} = -1.964635654$$

$$\text{So } x_4 = -1.9646 \text{ (4 d.p.)}$$

$$(c) x_0 = 1.3$$

$$x_1 = (4 - e^{1.3})^{\frac{1}{2}} = 0.575\dots$$

$$x_2 = (4 - e^{0.575\dots})^{\frac{1}{2}} = 1.490\dots$$

$$x_3 = (4 - e^{1.490\dots})^{\frac{1}{2}} \quad \text{No solution}$$

The value of  $4 - e^{1.490\dots}$  is **negative**.

**You can not take the square root of a negative number.**

# Solutionbank

## Edexcel AS and A Level Modular Mathematics

### Exercise C, Question 3

#### Question:

- (a) Show that the equation  $x^5 - 5x - 6 = 0$  has a root in the interval (1, 2).
- (b) Stating the values of the constants  $p$ ,  $q$  and  $r$ , use an iteration of the form  $x_{n+1} = (px_n + q)^{\frac{1}{r}}$  an appropriate number of times to calculate this root of the equation  $x^5 - 5x - 6 = 0$  correct to 3 decimal places. Show sufficient working to justify your final answer.

[E]

#### Solution:

- (a) Let  $f(x) = x^5 - 5x - 6$   
 $f(1) = (1)^5 - 5(1) - 6 = 1 - 5 - 6 = -10$   
 $f(2) = (2)^5 - 5(2) - 6 = 32 - 10 - 6 = 16$   
 $f(1) < 0$  and  $f(2) > 0$  so there is a change of sign.  
 $\Rightarrow$  There is a root between  $x = 1$  and  $x = 2$ .

- (b)  $x^5 - 5x - 6 = 0$   
 $x^5 - 6 = 5x$  Add  $5x$  to each side  
 $x^5 = 5x + 6$  Add 6 to each side  
 $x = (5x + 6)^{\frac{1}{5}}$  Take the fifth root of each side  
 So  $p = 5$ ,  $q = 6$  and  $r = 5$   
 Let  $x_0 = 1$  then

$$x_1 = [5(1) + 6]^{\frac{1}{5}} = 1.6153\dots$$

$$x_2 = [5(1.6153\dots) + 6]^{\frac{1}{5}} = 1.6970\dots$$

$$x_3 = 1.7068\dots$$

$$x_4 = 1.7079\dots$$

$$x_5 = 1.7080\dots$$

$$x_6 = 1.7081\dots$$

$$x_7 = 1.7081\dots$$

So the root is 1.708 (3 d.p.)

# Solutionbank

## Edexcel AS and A Level Modular Mathematics

### Exercise C, Question 4

#### Question:

$f(x) \equiv 5x - 4 \sin x - 2$ , where  $x$  is in radians.

(a) Evaluate, to 2 significant figures,  $f(1.1)$  and  $f(1.15)$ .

(b) State why the equation  $f(x) = 0$  has a root in the interval  $(1.1, 1.15)$ .  
An iteration formula of the form  $x_{n+1} = p \sin x_n + q$  is applied to find an approximation to the root of the equation  $f(x) = 0$  in the interval  $(1.1, 1.15)$ .

(c) Stating the values of  $p$  and  $q$ , use this iteration formula with  $x_0 = 1.1$  to find  $x_4$  to 3 decimal places. Show the intermediate results in your working.

[E]

#### Solution:

$$(a) f(1.1) = 5(1.1) - 4 \sin(1.1) - 2 = -0.0648\dots$$

$$f(1.15) = 5(1.15) - 4 \sin(1.15) - 2 = 0.0989\dots$$

(b)  $f(1.1) < 0$  and  $f(1.15) > 0$  so there is a change of sign.

$\Rightarrow$  There is a root between  $x = 1.1$  and  $x = 1.15$ .

$$(c) 5x - 4 \sin x - 2 = 0$$

$$5x - 2 = 4 \sin x \quad \text{Add } 4 \sin x \text{ to each side}$$

$$5x = 4 \sin x + 2 \quad \text{Add } 2 \text{ to each side}$$

$$\frac{5x}{5} = \frac{4 \sin x}{5} + \frac{2}{5} \quad \text{Divide each term by } 5$$

$$x = 0.8 \sin x + 0.4 \quad \text{Simplify}$$

$$\text{So } p = 0.8 \text{ and } q = 0.4$$

$$x_0 = 1.1$$

$$x_1 = 0.8 \sin(1.1) + 0.4 = 1.112965888$$

$$x_2 = 0.8 \sin(1.112965888) + 0.4 = 1.117610848$$

$$x_3 = 0.8 \sin(1.117610848) + 0.4 = 1.11924557$$

$$x_4 = 0.8 \sin(1.11924557) + 0.4 = 1.119817195$$

$$\text{So } x_4 = 1.120 \text{ (3 d.p.)}$$

# Solutionbank

## Edexcel AS and A Level Modular Mathematics

### Exercise C, Question 5

#### Question:

$f(x) \equiv 2 \sec x + 2x - 3$ , where  $x$  is in radians.

(a) Evaluate  $f(0.4)$  and  $f(0.5)$  and deduce the equation  $f(x) = 0$  has a solution in the interval  $0.4 < x < 0.5$ .

(b) Show that the equation  $f(x) = 0$  can be arranged in the form  $x = p + \frac{q}{\cos x}$ , where  $p$  and  $q$  are constants, and state the value of  $p$  and the value of  $q$ .

(c) Using the iteration formula  $x_{n+1} = p + \frac{q}{\cos x_n}$ ,  $x_0 = 0.4$ , with the values of  $p$  and  $q$  found in part (b), calculate  $x_1, x_2, x_3$  and  $x_4$ , giving your final answer to 4 decimal places.

[E]

#### Solution:

$$(a) f(0.4) = 2 \sec(0.4) + 2(0.4) - 3 = -0.0286$$

$$f(0.5) = 2 \sec(0.5) + 2(0.5) - 3 = 0.279$$

$f(0.4) < 0$  and  $f(0.5) > 0$  so there is a change of sign.

$\Rightarrow$  There is a root between  $x = 0.4$  and  $x = 0.5$ .

$$(b) 2 \sec x + 2x - 3 = 0$$

$$2 \sec x + 2x = 3 \quad \text{Add 3 to each side}$$

$$2x = 3 - 2 \sec x \quad \text{Subtract } 2 \sec x \text{ from each side}$$

$$\frac{2x}{2} = \frac{3}{2} - \frac{2 \sec x}{2} \quad \text{Divide each term by 2}$$

$$x = 1.5 - \sec x \quad \text{Simplify}$$

$$x = 1.5 - \frac{1}{\cos x} \quad \text{Use } \sec x = \frac{1}{\cos x}$$

So  $p = 1.5$  and  $q = -1$

$$(c) x_0 = 0.4$$

$$x_1 = 1.5 - \frac{1}{\cos(0.4)} = 0.4142955716$$

$$x_2 = 1.5 - \frac{1}{\cos(0.4142955716)} = 0.4075815187$$

$$x_3 = 1.5 - \frac{1}{\cos(0.4075815187)} = 0.4107728765$$

$$x_4 = 1.5 - \frac{1}{\cos(0.4107728765)} = 0.4092644032$$

So  $x_4 = 0.4093$  (4 d.p.)

© Pearson Education Ltd 2008

# Solutionbank

## Edexcel AS and A Level Modular Mathematics

### Exercise C, Question 6

#### Question:

$$f(x) \equiv e^{0.8x} - \frac{1}{3-2x}, x \neq \frac{3}{2}$$

(a) Show that the equation  $f(x) = 0$  can be written as  $x = 1.5 - 0.5e^{-0.8x}$ .

(b) Use the iteration formula  $x_{n+1} = 1.5 - 0.5e^{-0.8x_n}$  with  $x_0 = 1.3$  to obtain  $x_1, x_2$  and  $x_3$ . Give the value of  $x_3$ , an approximation to a root of  $f(x) = 0$ , to 3 decimal places.

(c) Show that the equation  $f(x) = 0$  can be written in the form  $x = p \ln(3 - 2x)$ , stating the value of  $p$ .

(d) Use the iteration formula  $x_{n+1} = p \ln(3 - 2x_n)$  with  $x_0 = -2.6$  and the value of  $p$  found in part (c) to obtain  $x_1, x_2$  and  $x_3$ . Give the value of  $x_3$ , an approximation to the second root of  $f(x) = 0$ , to 3 decimal places.

[E]

#### Solution:

$$(a) e^{0.8x} - \frac{1}{3-2x} = 0$$

$$e^{0.8x} = \frac{1}{3-2x} \quad \text{Add } \frac{1}{3-2x} \text{ to each side}$$

$$\left(3 - 2x\right) e^{0.8x} = \frac{1}{3-2x} \times \left(3 - 2x\right) \quad \text{Multiply each side by}$$

$$(3 - 2x)$$

$$(3 - 2x) e^{0.8x} = 1 \quad \text{Simplify}$$

$$\frac{(3 - 2x) e^{0.8x}}{e^{0.8x}} = \frac{1}{e^{0.8x}} \quad \text{Divide each side by } e^{0.8x}$$

$$3 - 2x = e^{-0.8x} \quad \text{Simplify (remember } \frac{1}{e^a} = e^{-a} \text{)}$$

$$3 = e^{-0.8x} + 2x \quad \text{Add } 2x \text{ to each side}$$

$$2x = 3 - e^{-0.8x} \quad \text{Subtract } e^{-0.8x} \text{ from each side}$$

$$\frac{2x}{2} = \frac{3}{2} - \frac{e^{-0.8x}}{2} \quad \text{Divide each term by 2}$$

$$x = 1.5 - 0.5e^{-0.8x} \quad \text{Simplify}$$

$$(b) x_0 = 1.3$$

$$x_1 = 1.5 - 0.5e^{-0.8(1.3)} = 1.323272659$$

$$x_2 = 1.5 - 0.5e^{-0.8(1.323272659)} = 1.32653255$$

$$x_3 = 1.5 - 0.5e^{-0.8(1.32653255)} = 1.326984349$$

$$\text{So } x_3 = 1.327 \text{ (3 d.p.)}$$

$$(c) e^{0.8x} - \frac{1}{3-2x} = 0$$

$$e^{0.8x} = \frac{1}{3-2x} \quad \text{Add } \frac{1}{3-2x} \text{ to each side}$$

$$0.8x = \ln \left( \frac{1}{3-2x} \right) \quad \text{Taking logs}$$

$$0.8x = -\ln(3-2x) \quad \text{Simplify using } \ln \left( \frac{1}{c} \right) = -\ln c$$

$$\frac{0.8x}{0.8} = -\frac{\ln(3-2x)}{0.8} \quad \text{Divide each side by 0.8}$$

$$x = -1.25 \ln(3-2x) \quad \text{Simplify } \left( \frac{1}{0.8} = 1.25 \right)$$

$$\text{So } p = -1.25$$

$$(d) x_0 = -2.6$$

$$x_1 = -1.25 \ln [ 3 - 2(-2.6) ] = -2.630167693$$

$$x_2 = -1.25 \ln [ 3 - 2(-2.630167693) ] = -2.639331488$$

$$x_3 = -1.25 \ln [ 3 - 2(-2.639331488) ] = -2.642101849$$

$$\text{So } x_3 = -2.642 \text{ (3 d.p.)}$$



# Solutionbank

## Edexcel AS and A Level Modular Mathematics

Exercise C, Question 7

### Question:

(a) Use the iteration  $x_{n+1} = (3x_n + 3)^{\frac{1}{3}}$  with  $x_0 = 2$  to find, to 3 significant figures,  $x_4$ .

The only real root of the equation  $x^3 - 3x - 3 = 0$  is  $\alpha$ . It is given that, to 3 significant figures,  $\alpha = x_4$ .

(b) Use the substitution  $y = 3^x$  to express  $27^x - 3^{x+1} - 3 = 0$  as a cubic equation.

(c) Hence, or otherwise, find an approximate solution to the equation  $27^x - 3^{x+1} - 3 = 0$ , giving your answer to 2 significant figures.

[E]

### Solution:

(a)  $x_0 = 2$

$$x_1 = [3(2) + 3]^{\frac{1}{3}} = 2.080083823$$

$$x_2 = [3(2.080083823) + 3]^{\frac{1}{3}} = 2.098430533$$

$$x_3 = [3(2.098430533) + 3]^{\frac{1}{3}} = 2.102588765$$

$$x_4 = [3(2.102588765) + 3]^{\frac{1}{3}} = 2.103528934$$

So  $x_4 = 2.10$  (3 s.f.)

(b)  $27^x - 3^{x+1} - 3 = 0$

$$(3^3)^x - 3(3^x) - 3 = 0$$

$$3^{3x} - 3(3^x) - 3 = 0$$

$$(3^x)^3 - 3(3^x) - 3 = 0$$

Let  $y = 3^x$

then  $y^3 - 3y - 3 = 0$

(c) The root of the equation  $y^3 - 3y - 3 = 0$  is  $x_4$

so  $y = 2.10$  (3 s.f.)

but  $y = 3^x$

so  $3^x = 2.10$

$\ln 3^x = \ln 2.10$     Take logs of each side

$x \ln 3 = \ln 2.10$     Simplify using  $\ln a^b = b \ln a$

$\frac{x \ln 3}{\ln 3} = \frac{\ln 2.10}{\ln 3}$     Divide each side by  $\ln 3$

$x = \frac{\ln 2.10}{\ln 3}$     Simplify

$x = 0.6753\dots$

So  $x = 0.68$  (2 s.f.)

# Solutionbank

## Edexcel AS and A Level Modular Mathematics

Exercise C, Question 8

### Question:

The equation  $x^x = 2$  has a solution near  $x = 1.5$ .

(a) Use the iteration formula  $x_{n+1} = 2 \frac{1}{x_n}$  with  $x_0 = 1.5$  to find the approximate solution  $x_5$  of the equation. Show the intermediate iterations and give your final answer to 4 decimal places.

(b) Use the iteration formula  $x_{n+1} = 2x_n^{(1-x_n)}$  with  $x_0 = 1.5$  to find  $x_1, x_2, x_3, x_4$ . Comment briefly on this sequence.

[E]

### Solution:

$$(a) x_0 = 1.5$$

$$x_1 = 2 \frac{1}{1.5} = 1.587401052$$

$$x_2 = 2 \frac{1}{1.587401052} = 1.54752265$$

$$x_3 = 2 \frac{1}{1.54752265} = 1.565034105$$

$$x_4 = 2 \frac{1}{1.565034105} = 1.557210213$$

$$x_5 = 2 \frac{1}{1.557210213} = 1.560679241$$

$$\text{So } x_5 = 1.5607 \text{ (4 d.p.)}$$

$$(b) x_0 = 1.5$$

$$x_1 = 2 \times (1.5)^{1-(1.5)} = 1.632993162$$

$$x_2 = 2 \times (1.632993162)^{1-(1.632993162)} = 1.466264596$$

$$x_3 = 2 \times (1.466264596)^{1-(1.466264596)} = 1.673135301$$

$$x_4 = 2 \times (1.673135301)^{1-(1.673135301)} = 1.414371012$$

The sequence  $x_0, x_1, x_2, x_3, x_4$  gets further from the root. It is a divergent sequence.

# Solutionbank

## Edexcel AS and A Level Modular Mathematics

### Exercise C, Question 9

#### Question:

(a) Show that the equation  $2^{1-x} = 4x + 1$  can be arranged in the form  $x = \frac{1}{2} \left( 2^{-x} \right) + q$ , stating the value of the constant  $q$ .

(b) Using the iteration formula  $x_{n+1} = \frac{1}{2} \left( 2^{-x_n} \right) + q$  with  $x_0 = 0.2$  and the value of  $q$  found in part (a), find  $x_1$ ,  $x_2$ ,  $x_3$  and  $x_4$ . Give the value of  $x_4$ , to 4 decimal places.

[E]

#### Solution:

$$(a) 2^{1-x} = 4x + 1$$

$$4x = 2^{1-x} - 1 \quad \text{Subtract 1 from each side}$$

$$4x = 2 \left( 2^{-x} \right) - 1 \quad \text{Use } 2^{a+b} = 2^a \times 2^b \text{ and } 2^1 = 2$$

$$\frac{4x}{4} = \frac{2}{4} \left( 2^{-x} \right) - \frac{1}{4} \quad \text{Divide each term by 4}$$

$$x = \frac{1}{2} \left( 2^{-x} \right) - \frac{1}{4} \quad \text{Simplify}$$

$$\text{So } q = -\frac{1}{4}$$

$$(b) x_0 = 0.2$$

$$x_1 = \frac{1}{2} \left( 2^{-0.2} \right) - \frac{1}{4} = 0.1852752816$$

$$x_2 = \frac{1}{2} \left( 2^{-0.1852752816} \right) - \frac{1}{4} = 0.1897406227$$

$$x_3 = \frac{1}{2} \left( 2^{-0.1897406227} \right) - \frac{1}{4} = 0.1883816687$$

$$x_4 = \frac{1}{2} \left( 2^{-0.1883816687} \right) - \frac{1}{4} = 0.1887947991$$

$$\text{So } x_4 = 0.1888 \text{ (4 d.p.)}$$

# Solutionbank

## Edexcel AS and A Level Modular Mathematics

Exercise C, Question 10

### Question:

The curve with equation  $y = \ln(3x)$  crosses the  $x$ -axis at the point P ( $p$ , 0).

(a) Sketch the graph of  $y = \ln(3x)$ , showing the exact value of  $p$ .

The normal to the curve at the point Q, with  $x$ -coordinate  $q$ , passes through the origin.

(b) Show that  $x = q$  is a solution of the equation  $x^2 + \ln 3x = 0$ .

(c) Show that the equation in part (b) can be rearranged in the form  $x = \frac{1}{3}e^{-x^2}$ .

(d) Use the iteration formula  $x_{n+1} = \frac{1}{3}e^{-x_n^2}$ , with  $x_0 = \frac{1}{3}$ , to find  $x_1$ ,  $x_2$ ,  $x_3$  and  $x_4$ . Hence write down, to 3 decimal places, an approximation for  $q$ .

[E]

### Solution:

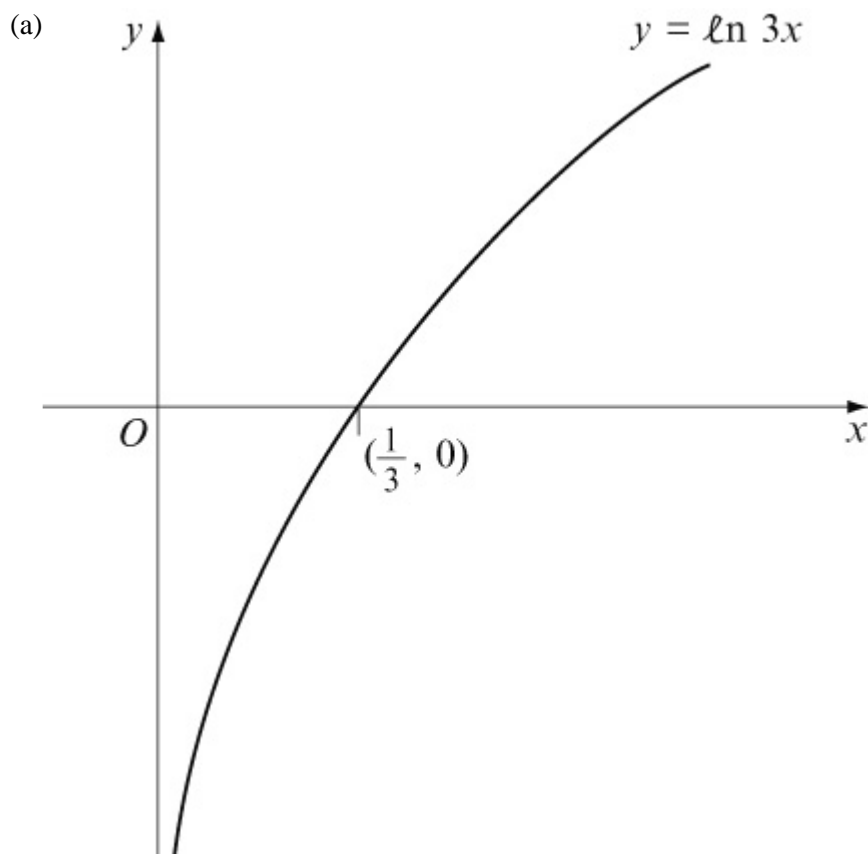

So  $p = \frac{1}{3}$

(b)①  $\frac{d}{dx} \ln 3x = \frac{1}{x}$

So the gradient of the tangent at Q is  $\frac{1}{q}$ .

The gradient of the normal is  $-q$  (because the product of the gradients of perpendicular lines is  $-1$ ).

The equation of the line with gradient  $-q$  that passes through  $(0, 0)$  is

$$y - y_1 = m (x - x_1)$$

$$y - 0 = -q (x - 0)$$

$$y = -qx$$

② The line  $y = -qx$  meets the curve  $y = \ln 3x$  when

$$\ln 3x = -qx$$

We know they meet at Q.

So, substitute  $x = q$  into  $\ln 3x = -qx$ :

$$\ln 3q = -q(q)$$

$$\ln 3q = -q^2$$

$$q^2 + \ln 3q = 0 \quad \text{Add } q^2 \text{ to each side}$$

This is  $x^2 + \ln 3x = 0$  with  $x = q$

So  $x = q$  is a solution of the equation  $x^2 + \ln 3x = 0$

$$(c) x^2 + \ln 3x = 0$$

$$\ln 3x = -x^2 \quad \text{Subtract } x^2 \text{ from each side}$$

$$3x = e^{-x^2} \quad \text{Use } \ln a = b \Rightarrow a = e^b$$

$$x = \frac{1}{3}e^{-x^2} \quad \text{Divide each term by 3}$$

$$(d) x_0 = \frac{1}{3}$$

$$x_1 = \frac{1}{3}e^{-\left(\frac{1}{3}\right)^2} = 0.2982797723$$

$$x_2 = \frac{1}{3}e^{-\left(0.2982797723\right)^2} = 0.3049574223$$

$$x_3 = \frac{1}{3}e^{-\left(0.3049574223\right)^2} = 0.3037314616$$

$$x_4 = \frac{1}{3}e^{-\left(0.3037314616\right)^2} = 0.3039581993$$

$$\text{So } x_4 = 0.304 \text{ (3 d.p.)}$$

# Solutionbank

## Edexcel AS and A Level Modular Mathematics

Exercise C, Question 11

### Question:

(a) Copy this sketch of the curve with equation  $y = e^{-x} - 1$ . On the same axes sketch the graph of  $y = \frac{1}{2} \left( x - 1 \right)$ , for  $x \geq 1$ , and  $y = -\frac{1}{2} \left( x - 1 \right)$ , for  $x < 1$ . Show the coordinates of the points where the graph meets the axes.

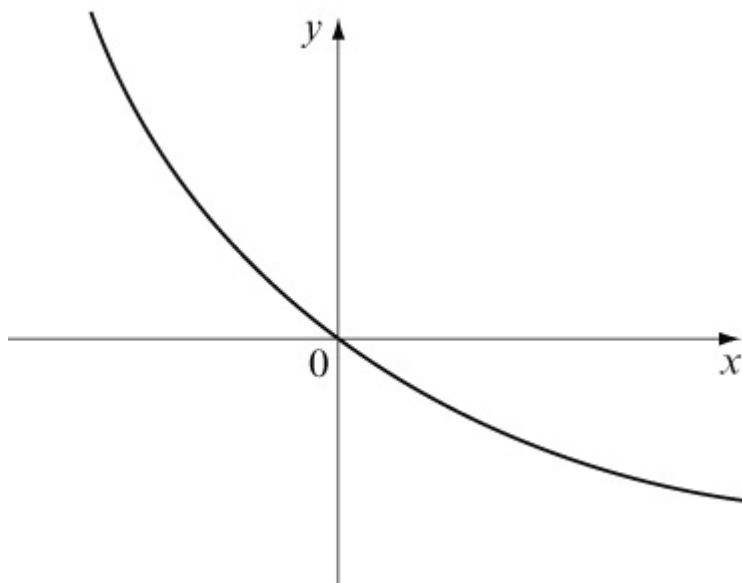

The  $x$ -coordinate of the point of intersection of the graphs is  $\alpha$ .

(b) Show that  $x = \alpha$  is a root of the equation  $x + 2e^{-x} - 3 = 0$ .

(c) Show that  $-1 < \alpha < 0$ .

The iterative formula  $x_{n+1} = -\ln \left[ \frac{1}{2} \left( 3 - x_n \right) \right]$  is used to solve the equation  $x + 2e^{-x} - 3 = 0$ .

(d) Starting with  $x_0 = -1$ , find the values of  $x_1$  and  $x_2$ .

(e) Show that, to 2 decimal places,  $\alpha = -0.58$ .

[E]

### Solution:



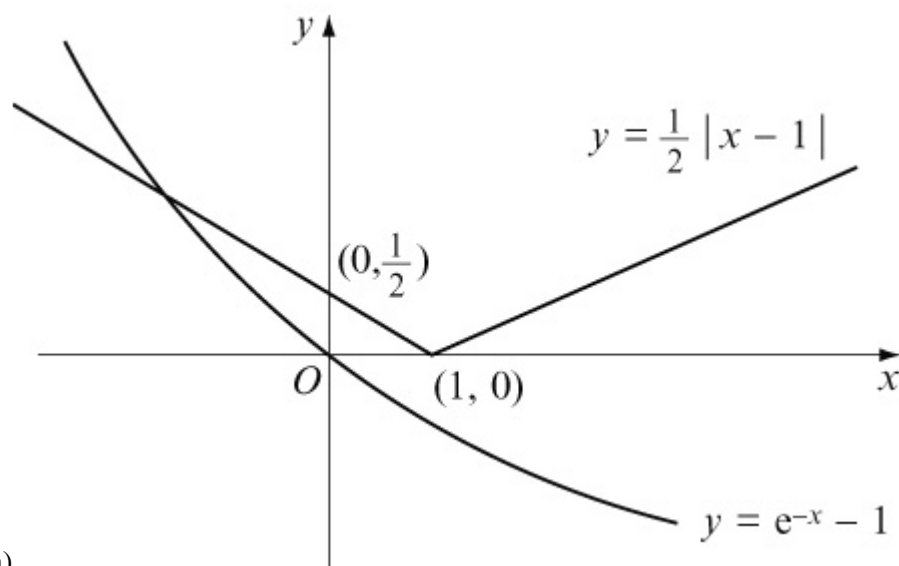

① Substitute  $x = 0$  into  $y = \frac{1}{2} |x - 1|$  :

$$y = \frac{1}{2} |-1| = \frac{1}{2}$$

So  $y = \frac{1}{2} |x - 1|$  meets the  $y$ -axis at  $(0, \frac{1}{2})$

② Substitute  $y = 0$  into  $y = \frac{1}{2} |x - 1|$  :

$$\frac{1}{2} |x - 1| = 0$$

$$x = 1$$

So  $y = \frac{1}{2} |x - 1|$  meets the  $x$ -axis at  $(1, 0)$

(b) The equation of the branch of the curve for  $x < 1$  is  $y = \frac{1}{2} (1 - x)$ .

This line meets the curve  $y = e^{-x} - 1$  when

$$\frac{1}{2} (1 - x) = e^{-x} - 1$$

$$(1 - x) = 2(e^{-x} - 1) \quad \text{Multiply each side by 2}$$

$$1 - x = 2e^{-x} - 2 \quad \text{Simplify}$$

$$-x = 2e^{-x} - 3 \quad \text{Subtract 1 from each side}$$

$$0 = x + 2e^{-x} - 3 \quad \text{Add } x \text{ to each side}$$

$$\text{or } x + 2e^{-x} - 3 = 0$$

The line meets the curve when  $x = \alpha$ , so  $x = \alpha$  is a root of the equation

$$x + 2e^{-x} - 3 = 0$$

(c) Let  $f(x) = x + 2e^{-x} - 3$

$$f(-1) = (-1) + 2e^{-(-1)} - 3 = 1.44$$

$$f(0) = (0) + 2e^{-(0)} - 3 = -1$$

$f(-1) > 0$  and  $f(0) < 0$  so there is a change of sign.

$\Rightarrow$  There is a root between  $x = -1$  and  $x = 0$ ,

i.e.  $-1 < \alpha < 0$

(d)  $x_0 = -1$

$$x_1 = -\ln \left\{ \frac{1}{2} \left[ 3 - \left( -1 \right) \right] \right\} = -0.6931471806$$

$$x_2 = -\ln \left\{ \frac{1}{2} \left[ 3 - \left( -0.6931471806 \right) \right] \right\} = -0.6133318084$$

(e)  $x_3 = -\ln \left\{ \frac{1}{2} \left[ 3 - \left( -0.6133318084 \right) \right] \right\} = -0.5914831048$

$$x_4 = -\ln \left\{ \frac{1}{2} \left[ 3 - \left( -0.5914831048 \right) \right] \right\} = -0.5854180577$$

$$x_5 = -\ln \left\{ \frac{1}{2} \left[ 3 - \left( -0.5854180577 \right) \right] \right\} = -0.5837278997$$

$$x_6 = -\ln \left\{ \frac{1}{2} \left[ 3 - \left( -0.5837278997 \right) \right] \right\} = -0.5832563908$$

So  $\alpha = -0.58$  (2 d.p.)

# Solutionbank

## Edexcel AS and A Level Modular Mathematics

### Exercise A, Question 1

#### Question:

Sketch the graph of each of the following. In each case, write down the coordinates of any points at which the graph meets the coordinate axes.

(a)  $y = |x - 1|$

(b)  $y = |2x + 3|$

(c)  $y = \left| \frac{1}{2}x - 5 \right|$

(d)  $y = |7 - x|$

(e)  $y = |x^2 - 7x - 8|$

(f)  $y = |x^2 - 9|$

(g)  $y = |x^3 + 1|$

(h)  $y = \left| \frac{12}{x} \right|$

(i)  $y = -|x|$

(j)  $y = -|3x - 1|$

#### Solution:

(a)

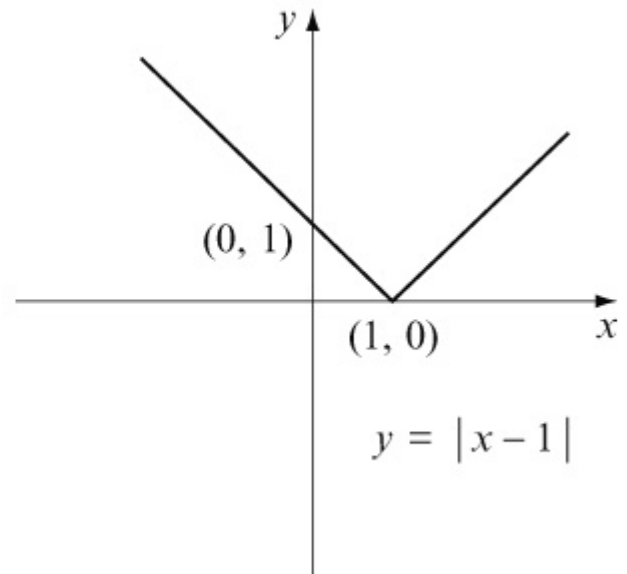
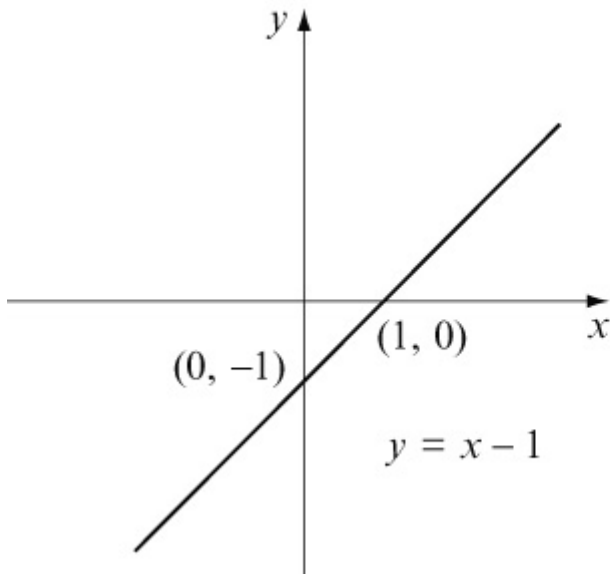

For  $y = |x - 1|$  :

When  $x = 0$ ,  $y = |-1| = 1$   $(0, 1)$

When  $y = 0$ ,  $x - 1 = 0 \Rightarrow x = 1$   $(1, 0)$

(b)

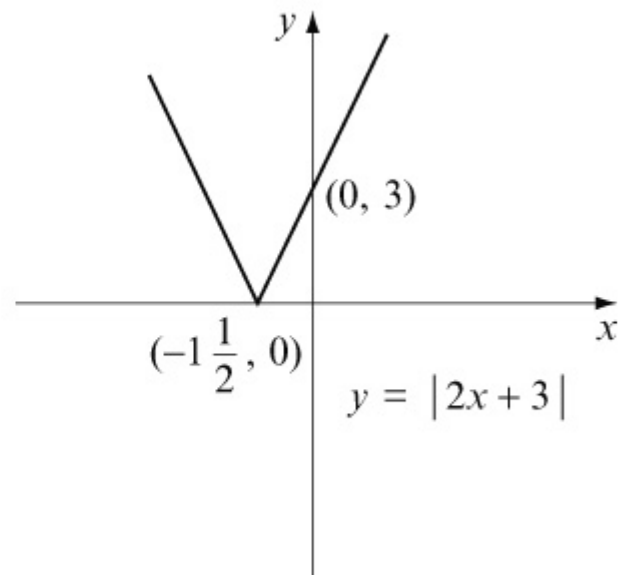
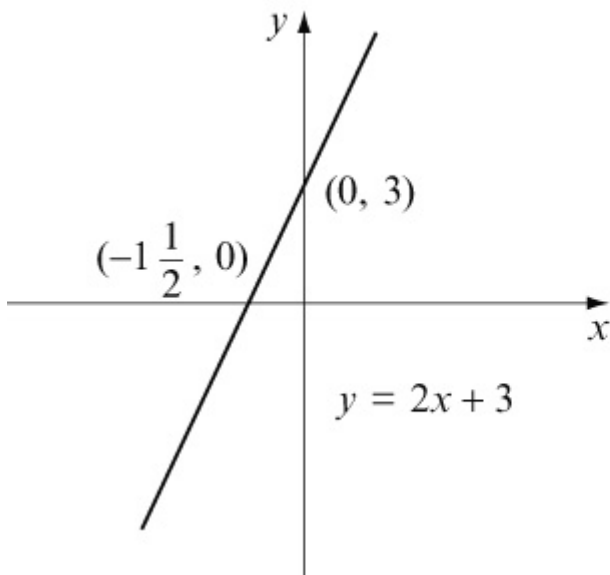

For  $y = |2x + 3|$  :

When  $x = 0$ ,  $y = |3| = 3$   $(0, 3)$

When  $y = 0$ ,  $2x + 3 = 0 \Rightarrow x = -\frac{3}{2}$   $(-1\frac{1}{2}, 0)$

(c)

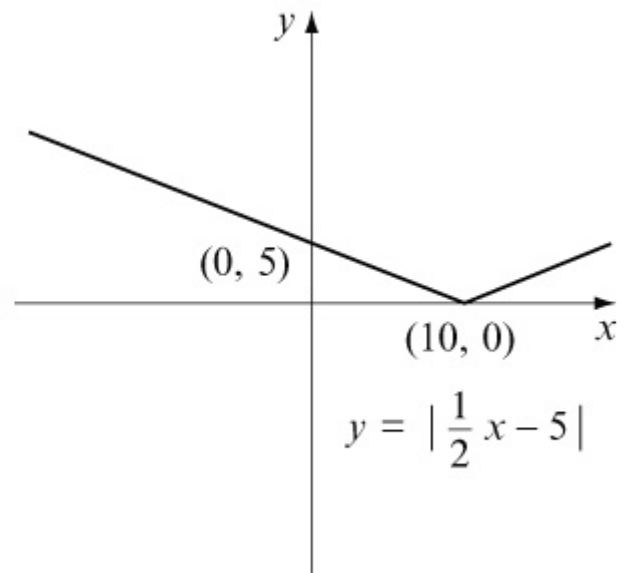
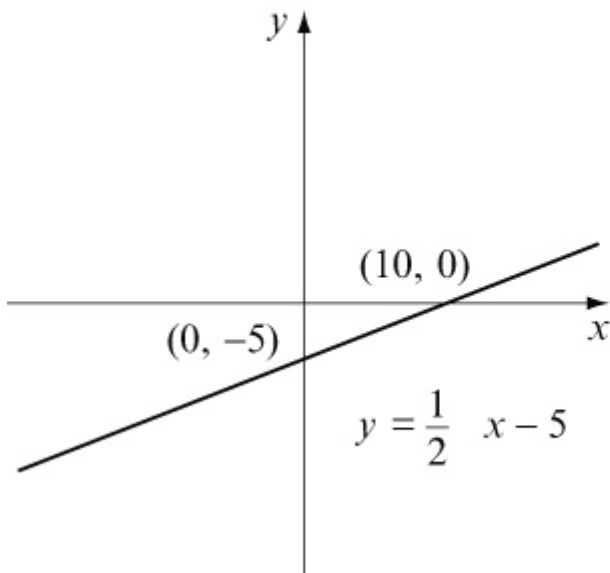

For  $y = \left| \frac{1}{2}x - 5 \right|$ :

When  $x = 0$ ,  $y = \left| -5 \right| = 5$   $(0, 5)$

When  $y = 0$ ,  $\frac{1}{2}x - 5 = 0 \Rightarrow x = 10$   $(10, 0)$

(d)

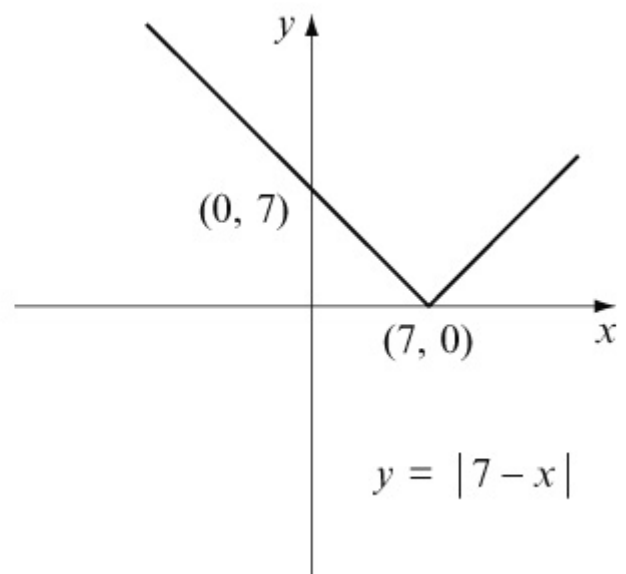
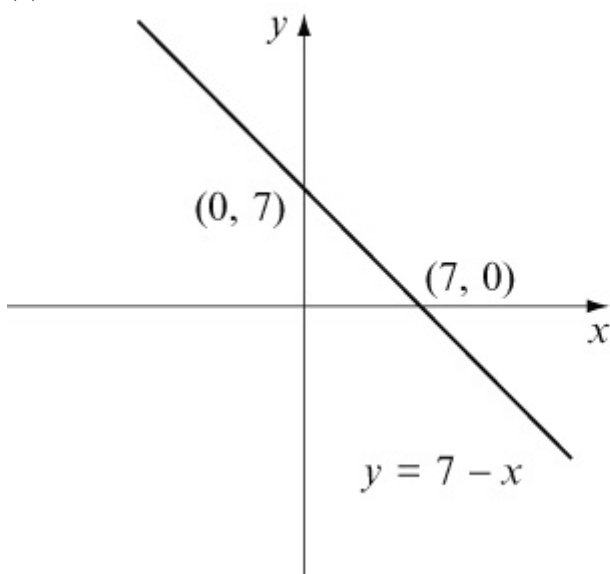

For  $y = |7 - x|$ :

When  $x = 0$ ,  $y = |7| = 7$   $(0, 7)$

When  $y = 0$ ,  $7 - x = 0 \Rightarrow x = 7$   $(7, 0)$

(e)  $x^2 - 7x - 8 = (x + 1)(x - 8)$

When  $y = 0$ ,  $(x + 1)(x - 8) = 0 \Rightarrow x = -1$  and  $x = 8$

Curve crosses x-axis at  $(-1, 0)$  and  $(8, 0)$

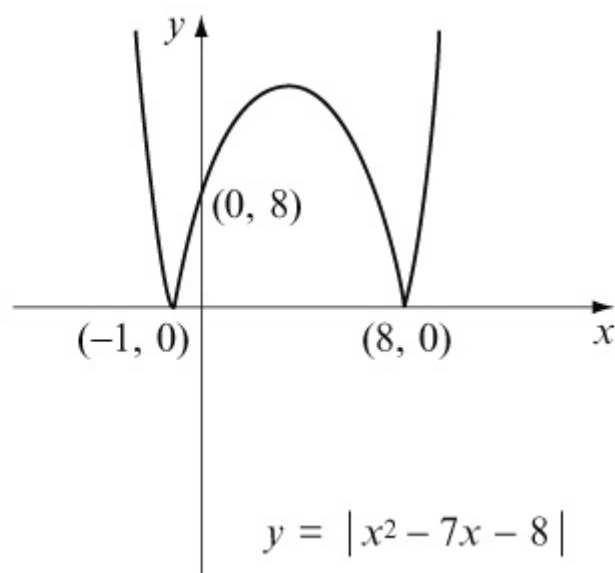
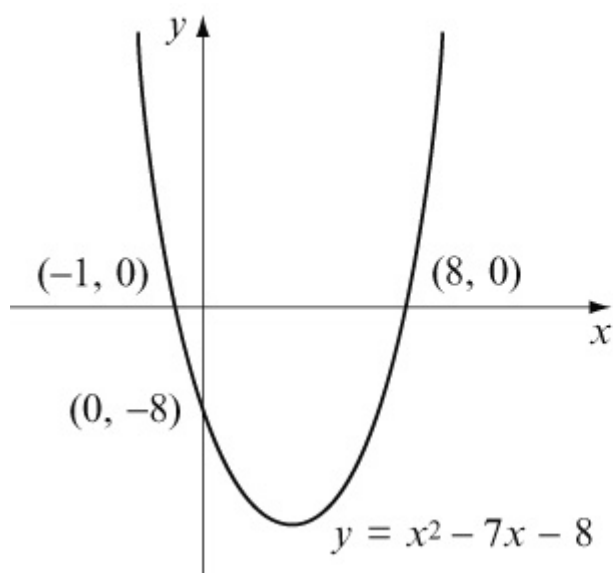

For  $y = |x^2 - 7x - 8|$  :

When  $x = 0$ ,  $y = |-8| = 8$   $(0, 8)$

(f)  $x^2 - 9 = (x + 3)(x - 3)$

When  $y = 0$ ,  $(x + 3)(x - 3) = 0 \Rightarrow x = -3$  and  $x = 3$

Curve crosses  $x$ -axis at  $(-3, 0)$  and  $(3, 0)$

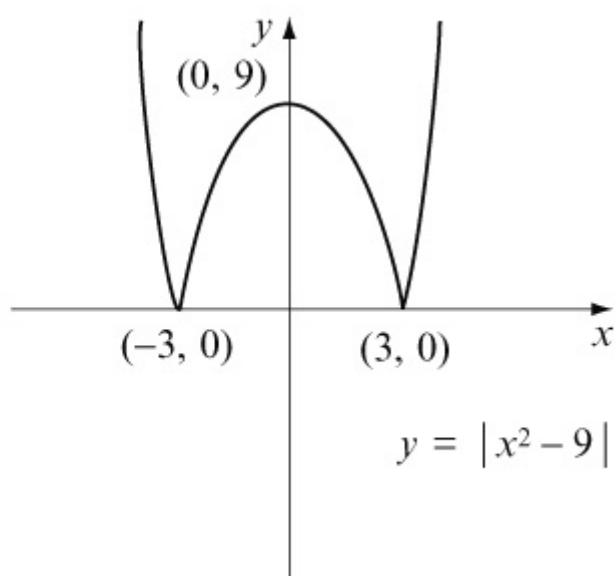
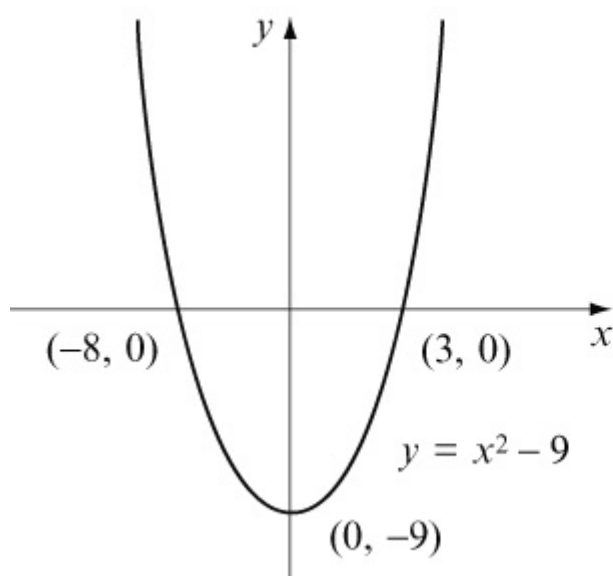

For  $y = |x^2 - 9|$  :

When  $x = 0$ ,  $y = |-9| = 9$   $(0, 9)$

(g) The graph of  $y = x^3 + 1$  is found by translating  $y = x^3$  by  $+1$  parallel to the  $y$ -axis.

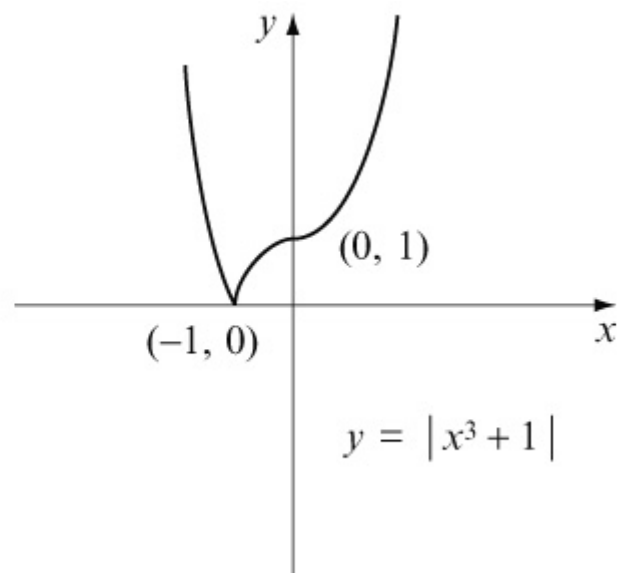
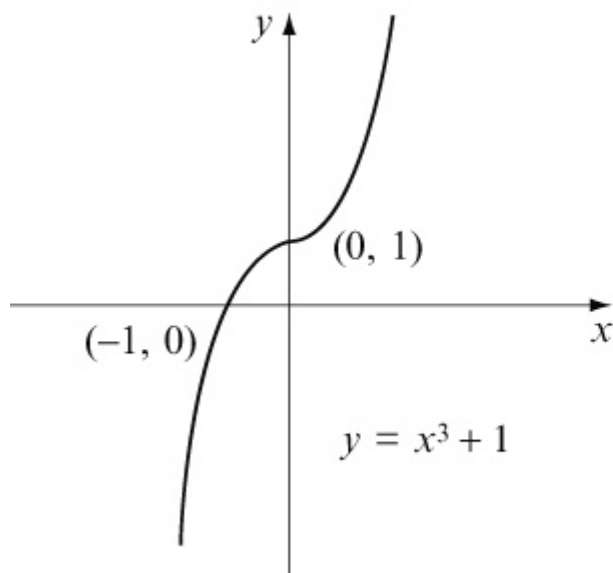

For  $y = |x^3 + 1|$  :

When  $x = 0$ ,  $y = |1| = 1$   $(0, 1)$

When  $y = 0$ ,  $x^3 + 1 = 0 \Rightarrow x^3 = -1 \Rightarrow x = -1$   $(-1, 0)$

(h)

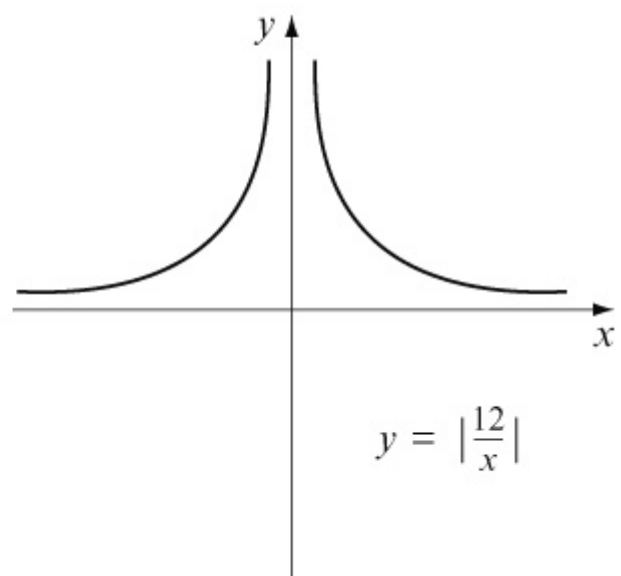
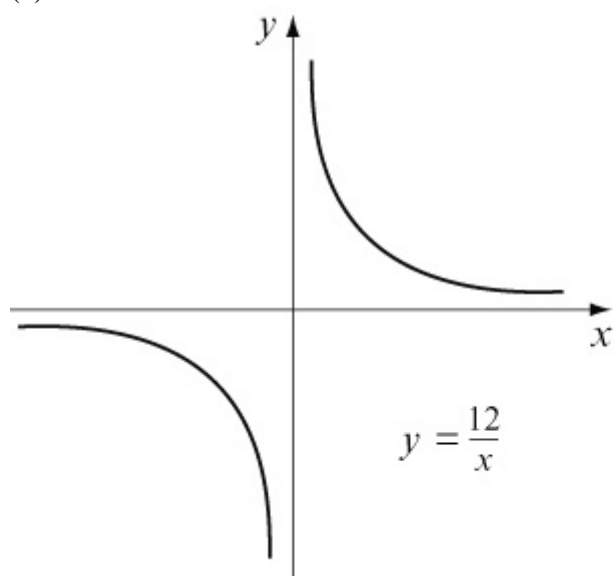

No intersections with the axes (the axes are asymptotes).

(i)

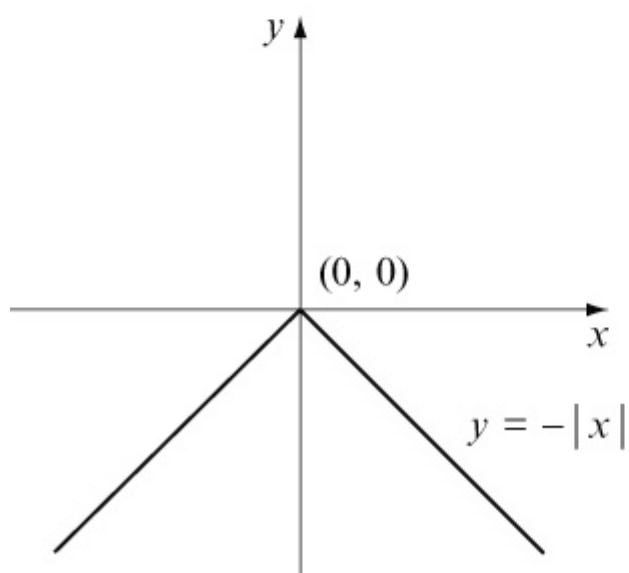
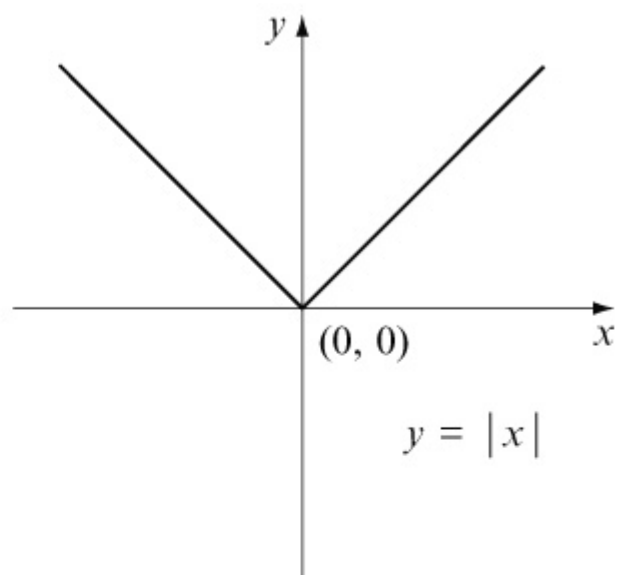
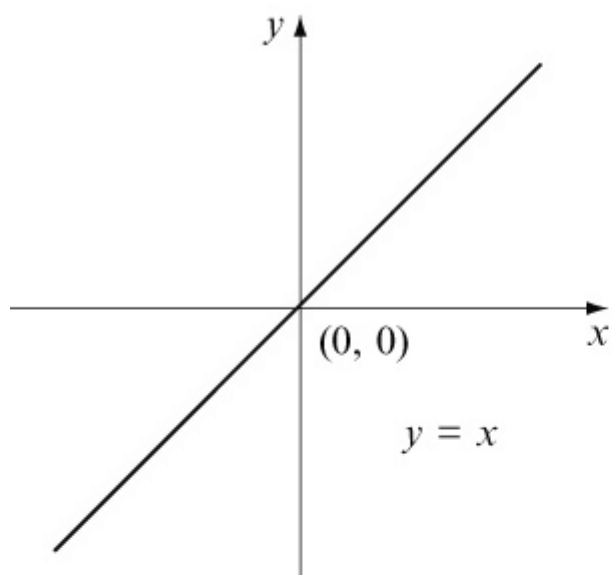

Passes through the origin  $(0, 0)$



(j)

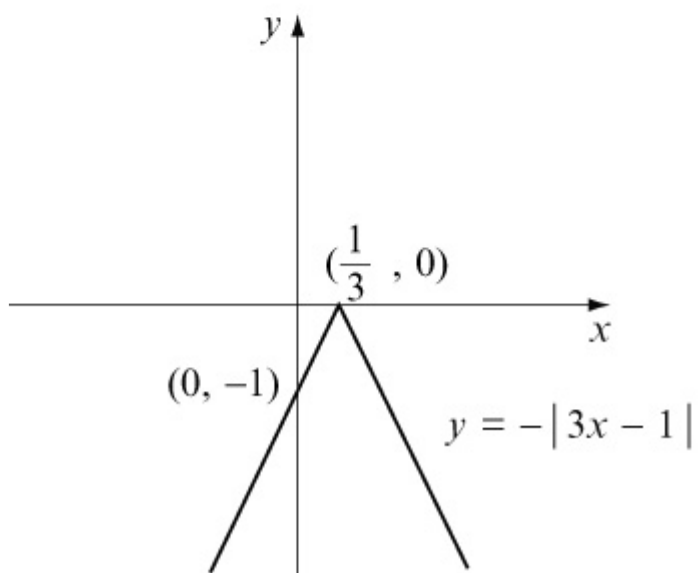
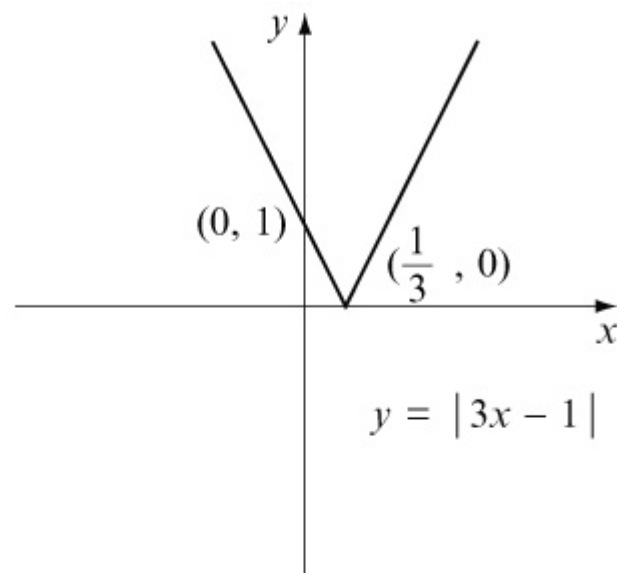
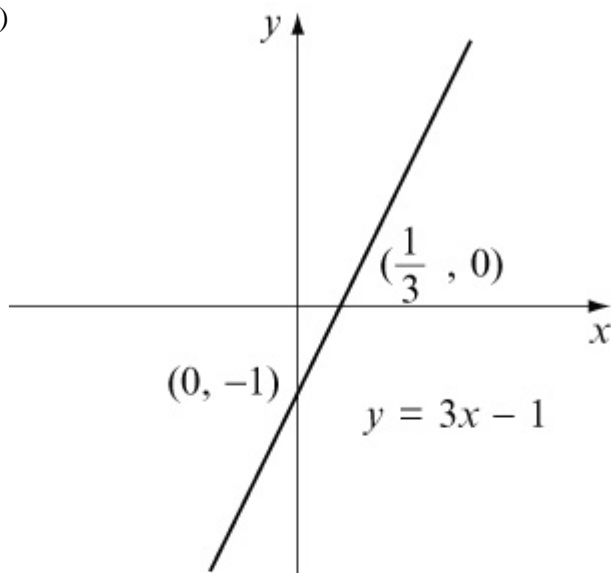

For  $y = -|3x - 1|$  :

When  $x = 0$ ,  $y = -|-1| = -1$   $(0, -1)$

When  $y = 0$ ,  $3x - 1 = 0 \Rightarrow x = \frac{1}{3}$   $(\frac{1}{3}, 0)$

# Solutionbank

## Edexcel AS and A Level Modular Mathematics

### Exercise A, Question 2

#### Question:

Sketch the graph of each of the following. In each case, write down the coordinates of any points at which the graph meets the coordinate axes.

(a)  $y = |\cos x|$ ,  $0 \leq x \leq 2\pi$

(b)  $y = |\ln x|$ ,  $x > 0$

(c)  $y = |2^x - 2|$

(d)  $y = |100 - 10^x|$

(e)  $y = |\tan 2x|$ ,  $0 < x < 2\pi$

#### Solution:

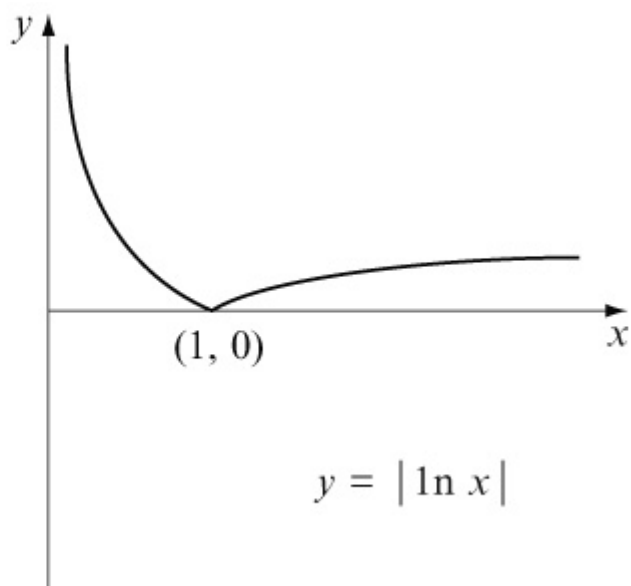
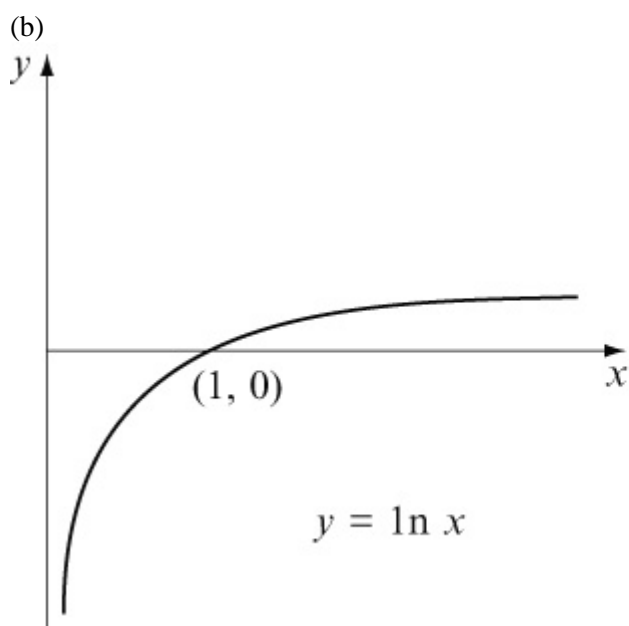
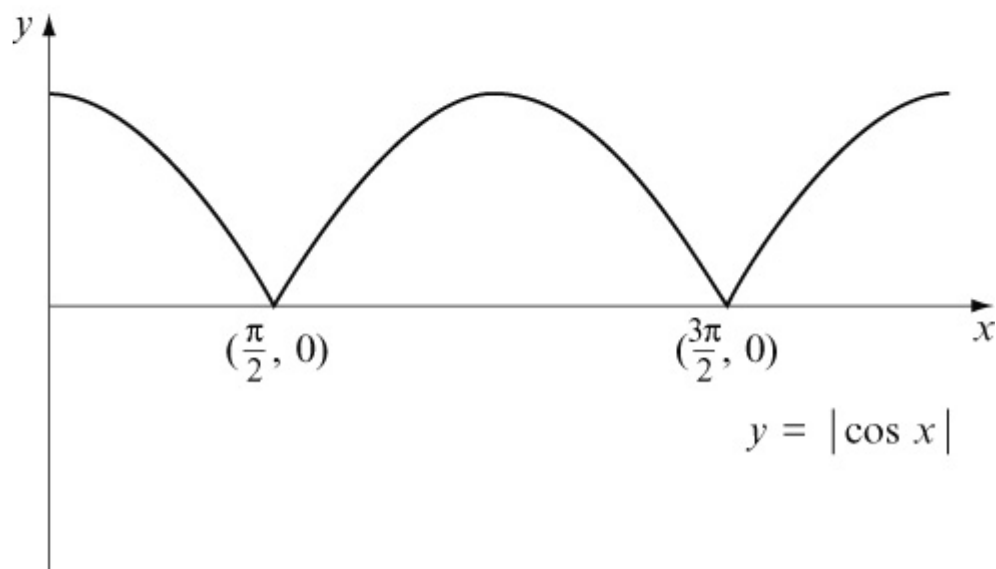
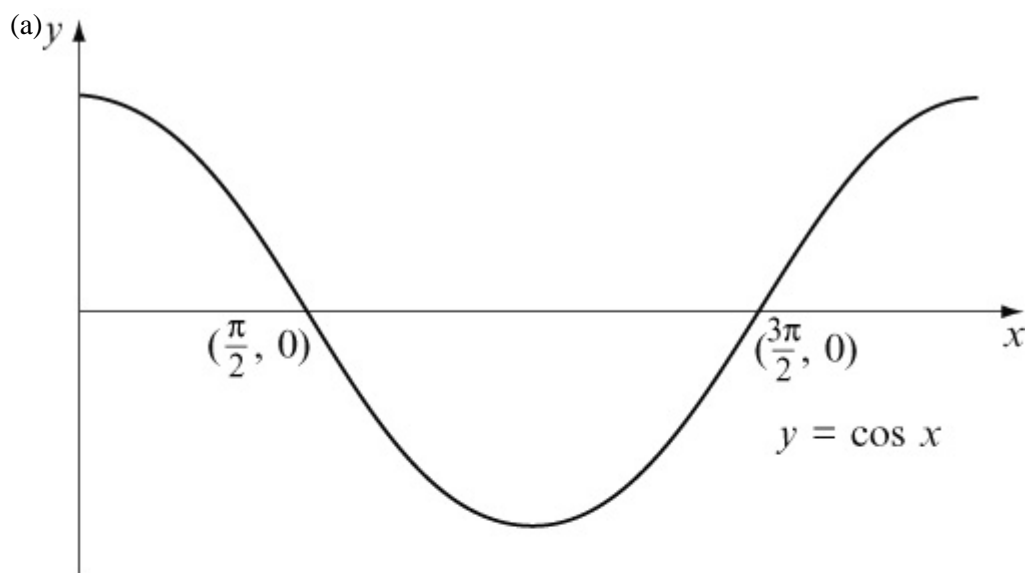

(c)

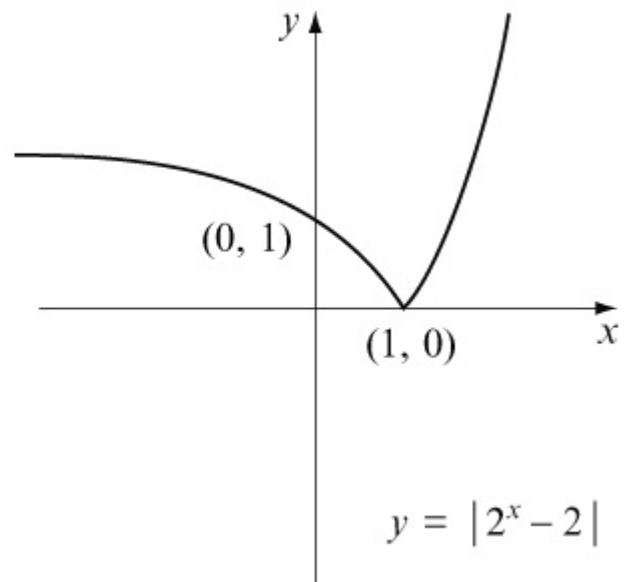
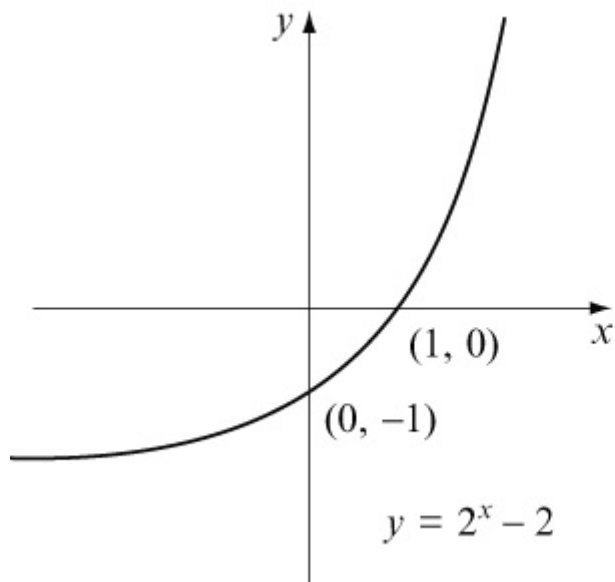

For  $y = |2^x - 2|$  :

When  $x = 0$ ,  $y = |2^0 - 2| = |-1| = 1$   $(0, 1)$

When  $y = 0$ ,  $2^x - 2 = 0 \Rightarrow 2^x = 2 \Rightarrow x = 1$   $(1, 0)$

(d)

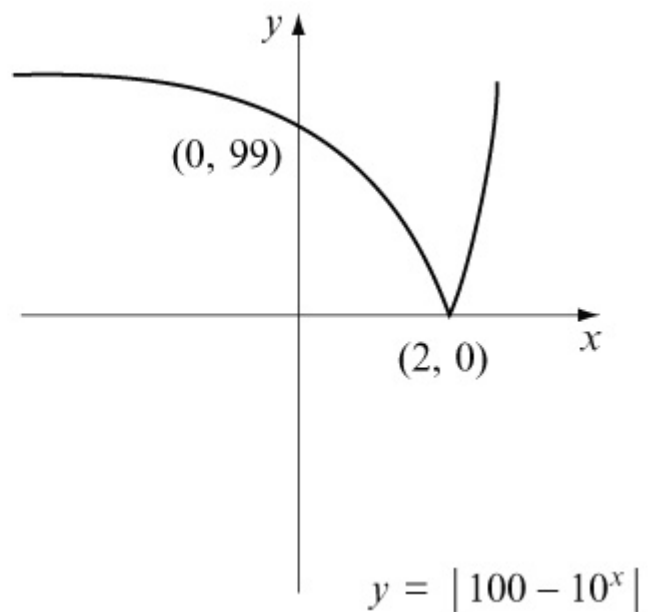
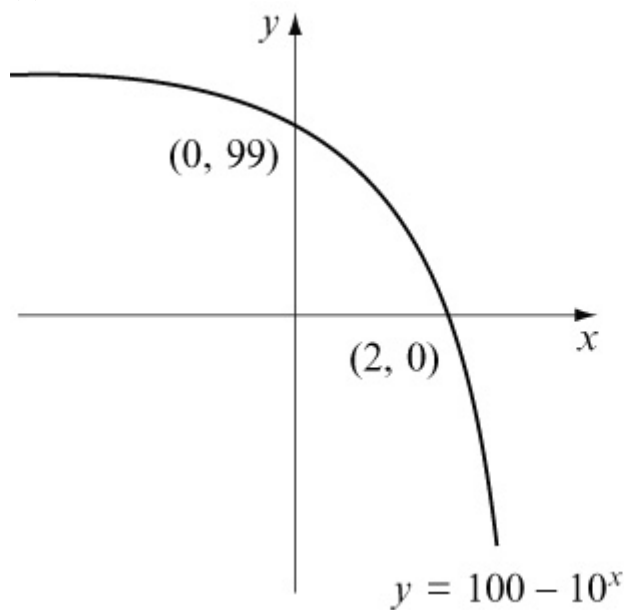

For  $y = |100 - 10^x|$  :

When  $x = 0$ ,  $y = |100 - 10^0| = |99| = 99$   $(0, 99)$

When  $y = 0$ ,  $100 - 10^x = 0 \Rightarrow 10^x = 100 \Rightarrow x = 2$   $(2, 0)$

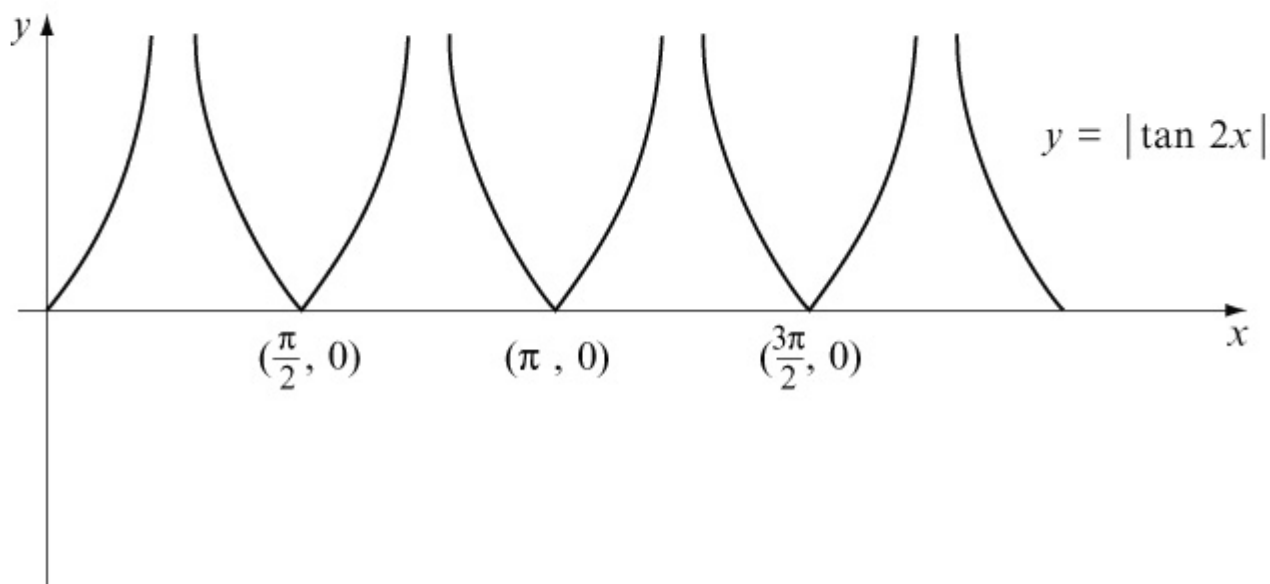
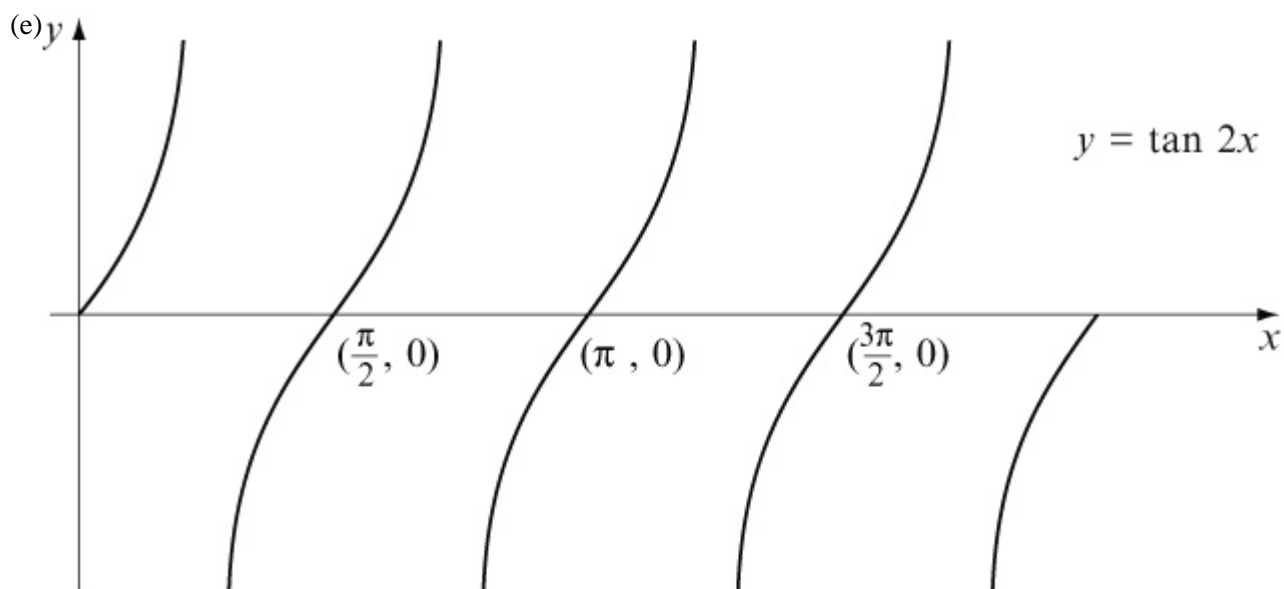

For  $y = |\tan 2x|$  :

When  $x = 0$ ,  $y = |\tan 0| = 0$

When  $y = 0$ ,  $\tan 2x = 0$

$$\Rightarrow x = 0, \frac{\pi}{2}, \pi, \frac{3\pi}{2}, 2\pi \dots \quad \left( \frac{\pi}{2}, 0 \right), (\pi, 0), \left( \frac{3\pi}{2}, 0 \right)$$

# Solutionbank

## Edexcel AS and A Level Modular Mathematics

### Exercise B, Question 1

#### Question:

Sketch the following graph and write down the coordinates of any points at which the graph meets the coordinate axes.

$$y = 2|x| + 1$$

#### Solution:

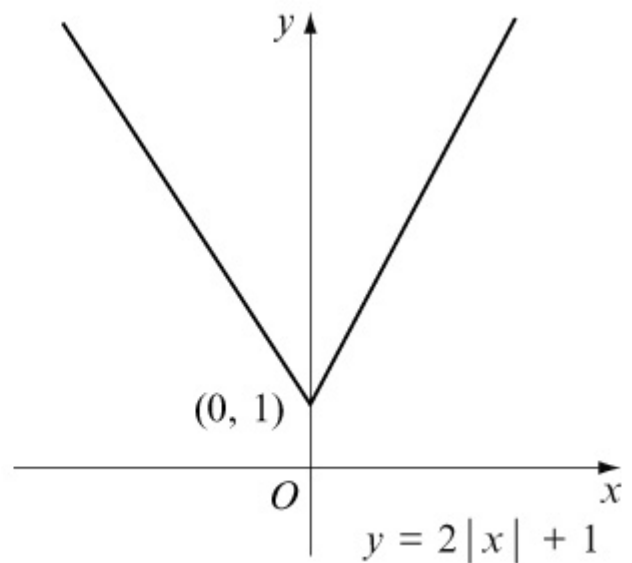
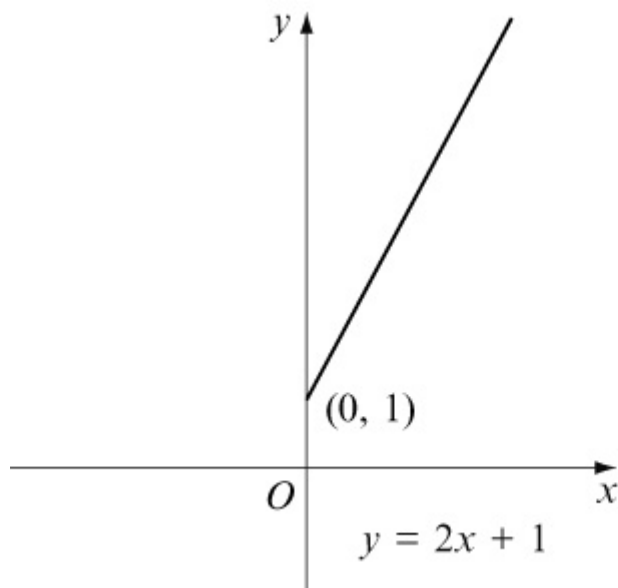

For  $y = 2|x| + 1$  :

When  $x = 0$ ,  $y = 1$       $(0, 1)$

When  $y = 0$ ,  $2|x| + 1 = 0$

$$\Rightarrow |x| = -\frac{1}{2}$$

No values ( $|x|$  cannot be negative).

# Solutionbank

## Edexcel AS and A Level Modular Mathematics

### Exercise B, Question 2

#### Question:

Sketch the following graph and write down the coordinates of any points at which the graph meets the coordinate axes.

$$y = |x|^2 - 3|x| - 4$$

#### Solution:

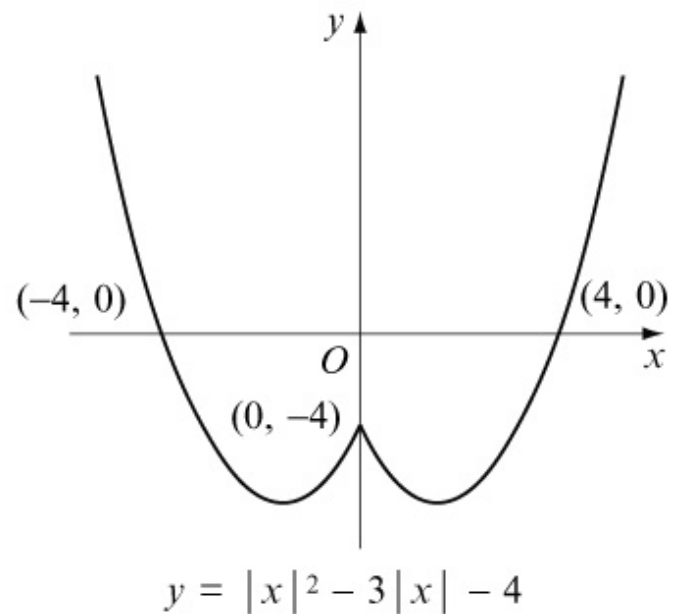
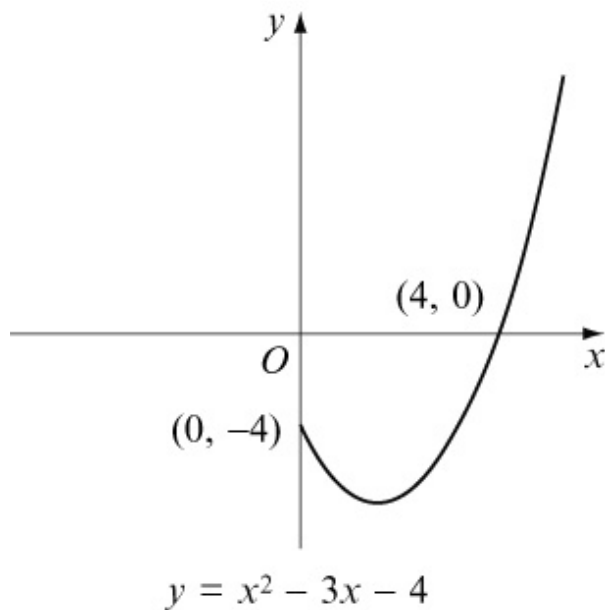

For  $y = |x|^2 - 3|x| - 4$ :

When  $x = 0$ ,  $y = -4$      $(0, -4)$

When  $y = 0$ ,  $|x|^2 - 3|x| - 4 = 0$

$$\Rightarrow (|x| + 1)(|x| - 4) = 0$$

$$\Rightarrow |x| = 4$$

$$\Rightarrow x = 4 \text{ or } -4 \quad (-4, 0) \text{ and } (4, 0)$$

# Solutionbank

## Edexcel AS and A Level Modular Mathematics

Exercise B, Question 3

### Question:

Sketch the following graph and write down the coordinates of any points at which the graph meets the coordinate axes.

$$y = \sin |x|, \quad -2\pi \leq x \leq 2\pi$$

### Solution:

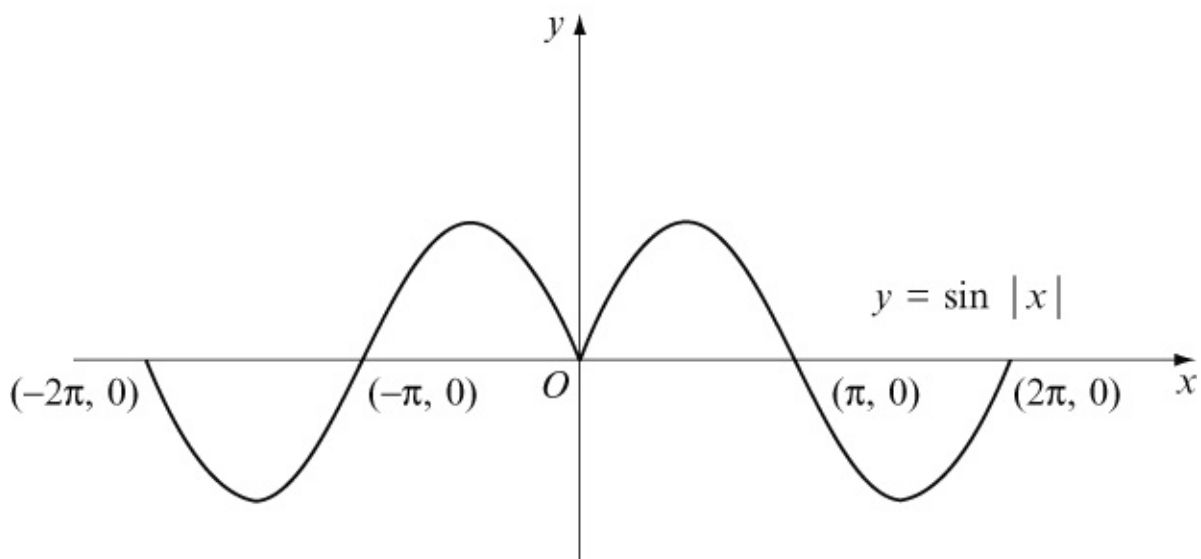
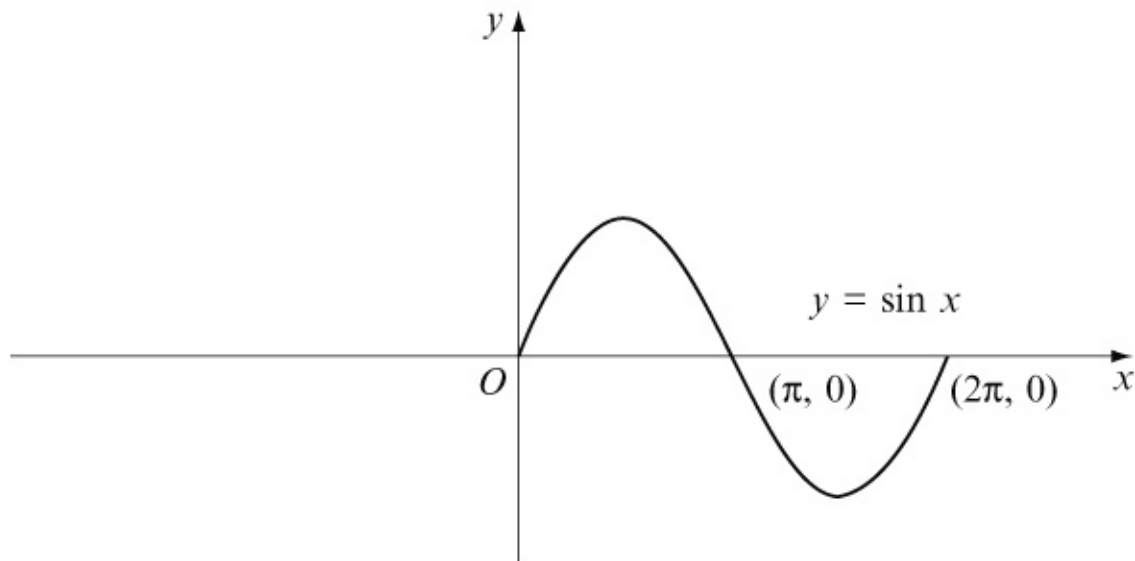

...



# Solutionbank

## Edexcel AS and A Level Modular Mathematics

Exercise B, Question 4

### Question:

Sketch the following graph and write down the coordinates of any points at which the graph meets the coordinate axes.

$$y = 2^{|x|}$$

### Solution:

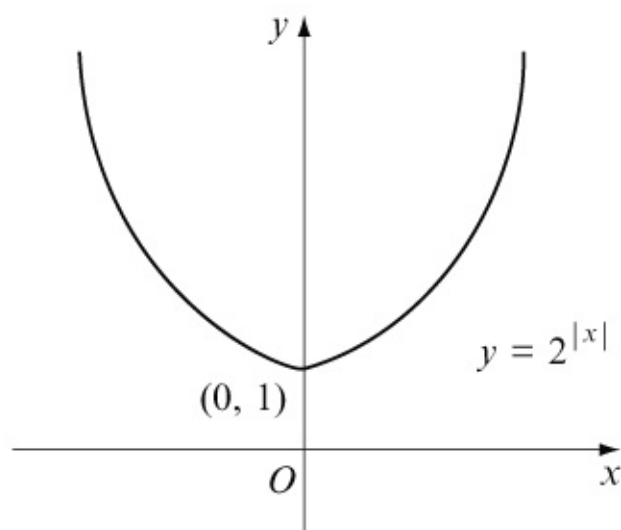
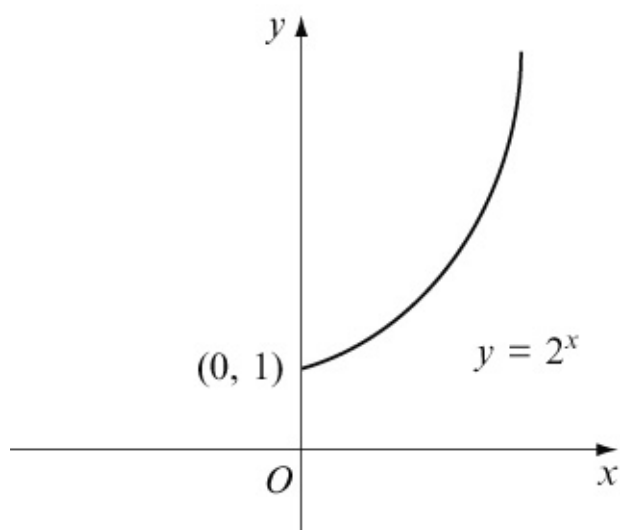

...

© Pearson Education Ltd 2008

# Solutionbank

## Edexcel AS and A Level Modular Mathematics

### Exercise C, Question 1

#### Question:

On the same diagram, sketch the graphs of  $y = -2x$  and  $y = \left| \frac{1}{2}x - 2 \right|$ .

Solve the equation  $-2x = \left| \frac{1}{2}x - 2 \right|$ .

#### Solution:

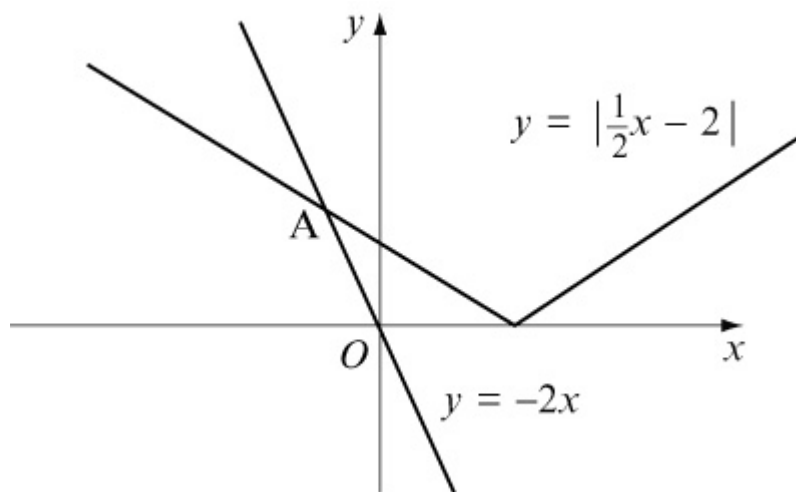

Intersection point A is on the reflected part of  $y = \frac{1}{2}x - 2$ .

$$-\left(\frac{1}{2}x - 2\right) = -2x$$

$$-\frac{1}{2}x + 2 = -2x$$

$$2x - \frac{1}{2}x = -2$$

$$\frac{3}{2}x = -2$$

$$x = -\frac{4}{3}$$

# Solutionbank

## Edexcel AS and A Level Modular Mathematics

### Exercise C, Question 2

#### Question:

On the same diagram, sketch the graphs of  $y = |x|$  and  $y = |-4x - 5|$ .  
Solve the equation  $|x| = |-4x - 5|$ .

#### Solution:

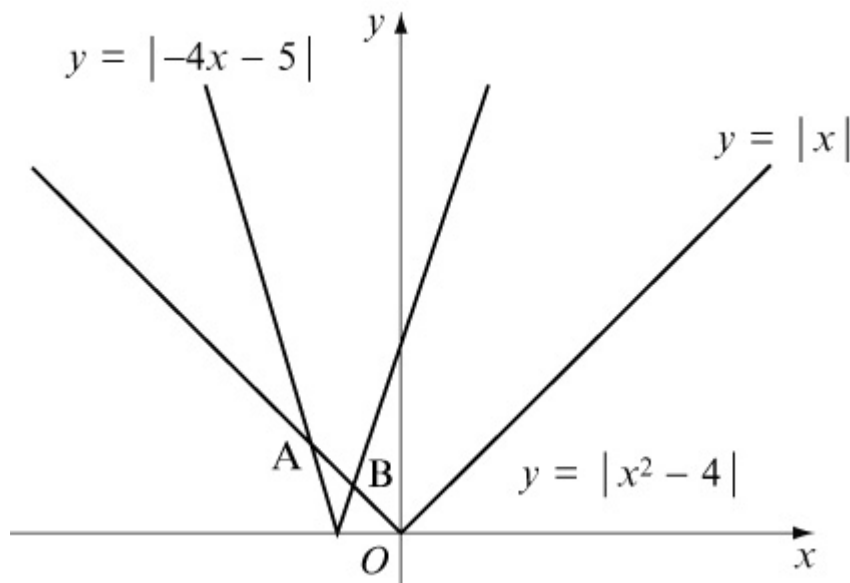

Intersection point A is on the reflected part of  $y = x$ .

$$-x = -4x - 5$$

$$4x - x = -5$$

$$3x = -5$$

$$x = -\frac{5}{3}$$

Intersection point B is on the reflected part of  $y = x$  and also on the reflected part of  $y = -4x - 5$ .

$$-x = -(-4x - 5)$$

$$-x = 4x + 5$$

$$-x - 4x = 5$$

$$-5x = 5$$

$$x = -1$$

# Solutionbank

## Edexcel AS and A Level Modular Mathematics

Exercise C, Question 3

### Question:

On the same diagram, sketch the graphs of  $y = 3x$  and  $y = |x^2 - 4|$ . Solve the equation  $3x = |x^2 - 4|$ .

### Solution:

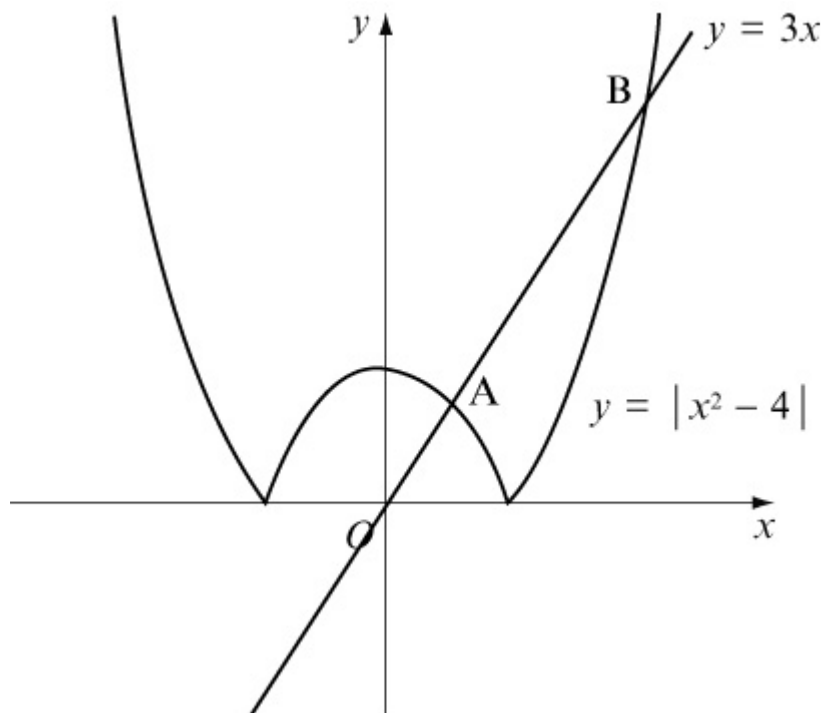

Intersection point A is on the reflected part of  $y = x^2 - 4$ .

$$3x = -(x^2 - 4)$$

$$x^2 + 3x - 4 = 0$$

$$(x + 4)(x - 1) = 0 \quad (x = -4 \text{ is not valid})$$

$$x = 1$$

Intersection point B:

$$3x = x^2 - 4$$

$$0 = x^2 - 3x - 4$$

$$0 = (x - 4)(x + 1) \quad (x = -1 \text{ is not valid})$$

$$x = 4$$

# Solutionbank

## Edexcel AS and A Level Modular Mathematics

### Exercise C, Question 4

#### Question:

On the same diagram, sketch the graphs of  $y = |x| - 1$  and  $y = -|3x|$ .  
Solve the equation  $|x| - 1 = -|3x|$ .

#### Solution:

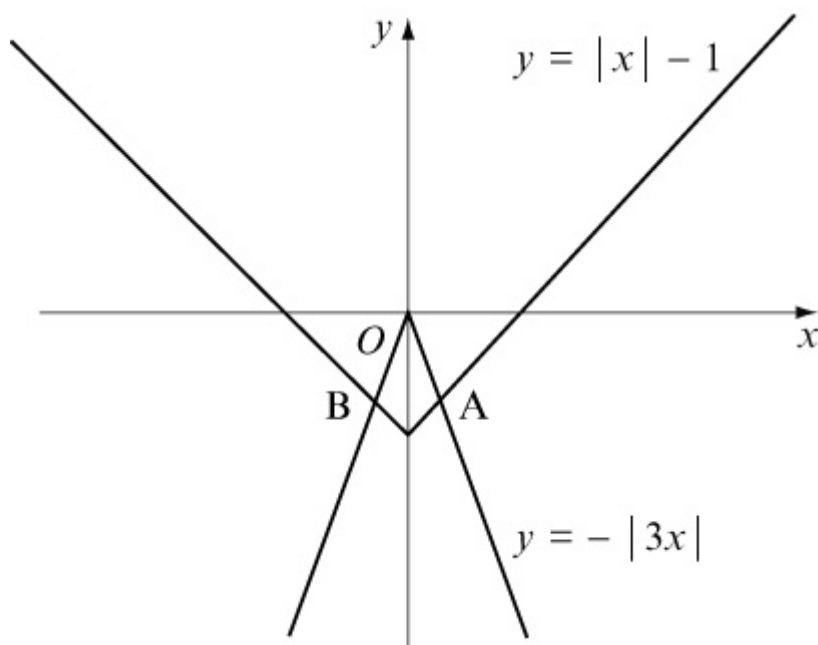

Intersection point A:

$$x - 1 = -3x$$

$$3x + x = 1$$

$$x = \frac{1}{4}$$

Intersection point B is on the reflected part of both graphs.

$$-(x) - 1 = -(-3x)$$

$$-x - 1 = 3x$$

$$-4x = 1$$

$$x = -\frac{1}{4}$$

# Solutionbank

## Edexcel AS and A Level Modular Mathematics

Exercise C, Question 5

### Question:

On the same diagram, sketch the graphs of  $y = 24 + 2x - x^2$  and  $y = |5x - 4|$ .  
Solve the equation  $24 + 2x - x^2 = |5x - 4|$ . (Answers to 2 d.p. where appropriate).

### Solution:

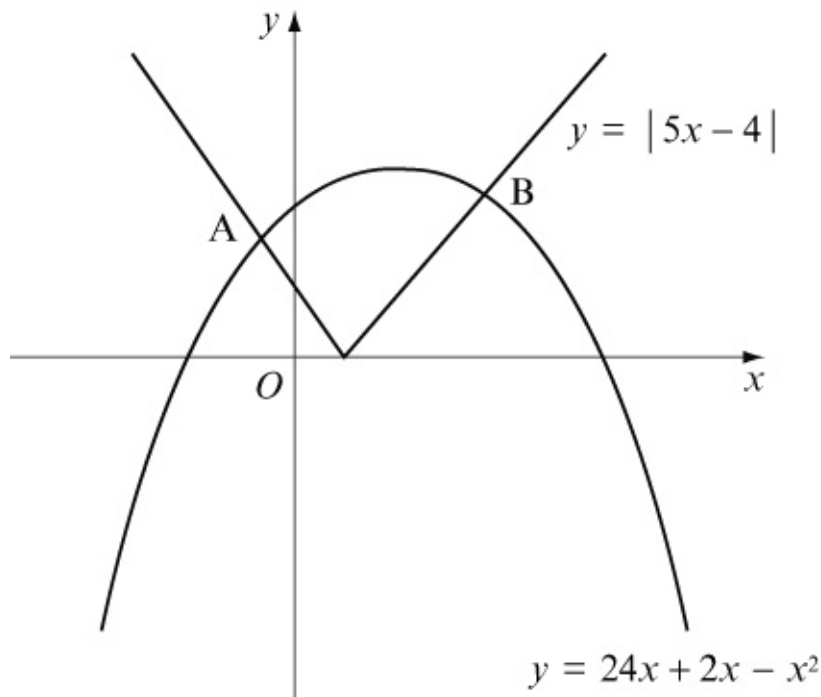

Intersection point A is on the reflected part of  $y = 5x - 4$ .

$$\begin{aligned} -(5x - 4) &= 24 + 2x - x^2 \\ -5x + 4 &= 24 + 2x - x^2 \\ x^2 - 7x - 20 &= 0 \\ x &= \frac{7 \pm \sqrt{49 + 80}}{2} \quad (\text{positive solution not valid}) \end{aligned}$$

$$x = -2.18 \text{ (2 d.p.)}$$

Intersection point B:

$$\begin{aligned} 5x - 4 &= 24 + 2x - x^2 \\ x^2 + 3x - 28 &= 0 \\ (x + 7)(x - 4) &= 0 \quad (x = -7 \text{ is not valid}) \\ x &= 4 \end{aligned}$$



# Solutionbank

## Edexcel AS and A Level Modular Mathematics

### Exercise D, Question 1

#### Question:

Using combinations of transformations, sketch the graph of each of the following:

(a)  $y = 2x^2 - 4$

(b)  $y = 3(x + 1)^2$

(c)  $y = \frac{3}{x} - 2$

(d)  $y = \frac{3}{x - 2}$

(e)  $y = 5 \sin(x + 30^\circ)$ ,  $0 \leq x \leq 360^\circ$

(f)  $y = \frac{1}{2}e^x + 4$

(g)  $y = |4x| + 1$

(h)  $y = 2x^3 - 3$

(i)  $y = 3 \ln(x - 2)$ ,  $x > 2$

(j)  $y = |2e^x - 3|$

#### Solution:

(a)  $y = x^2$



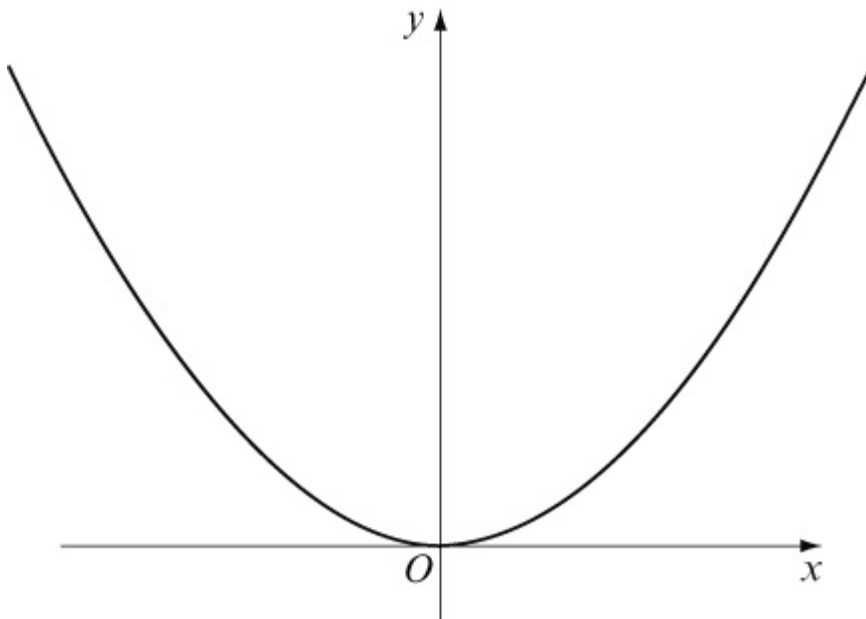

$y = 2x^2$ . Vertical stretch, scale factor 2.

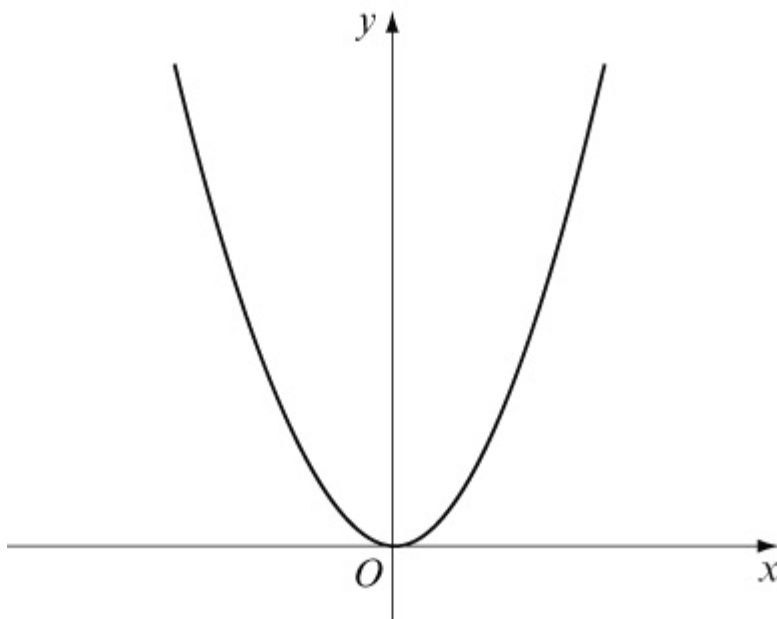

$y = 2x^2 - 4$ . Vertical translation of  $-4$ .

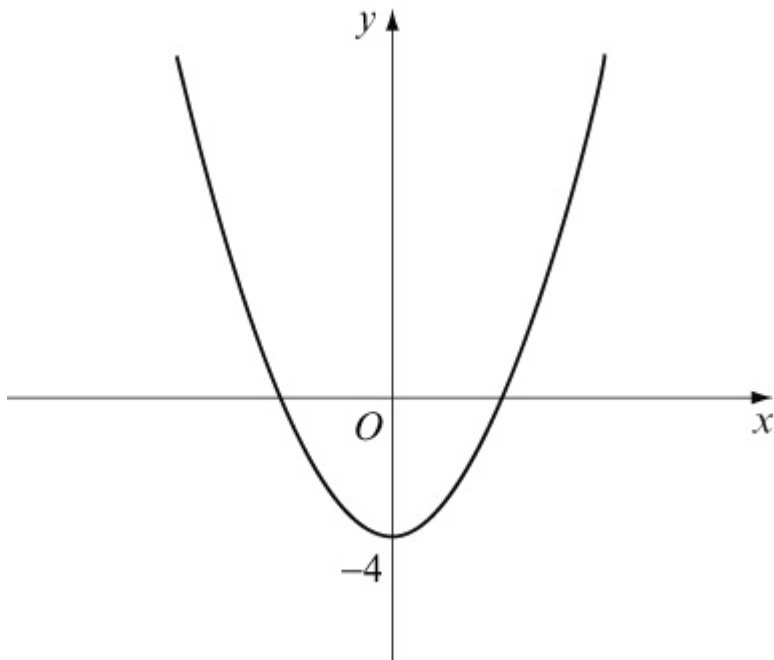

(b)  $y = x^2$

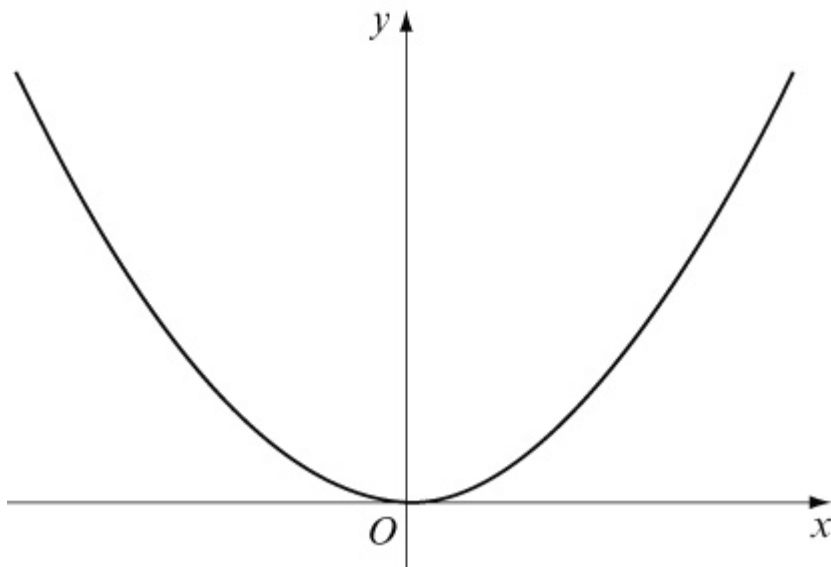

$y = (x + 1)^2$ . Horizontal translation of  $-1$ .

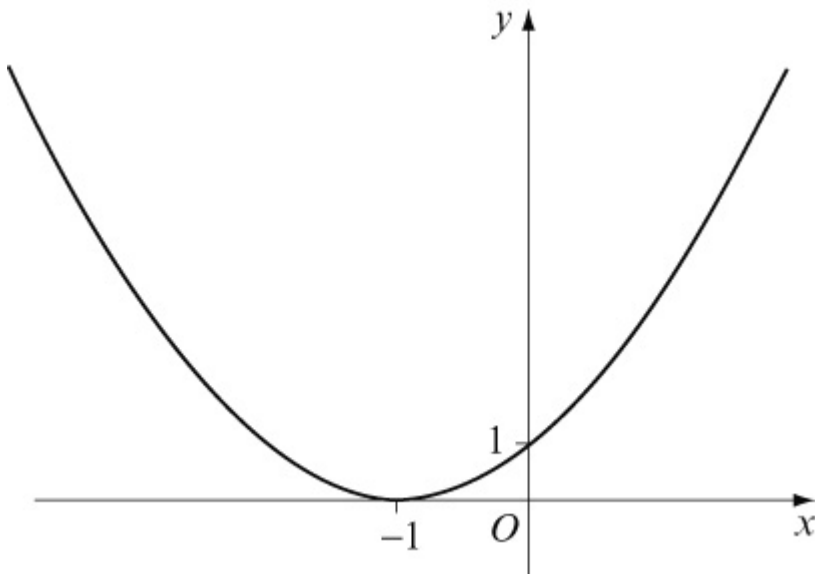

$y = 3(x + 1)^2$ . Vertical stretch, scale factor 3.

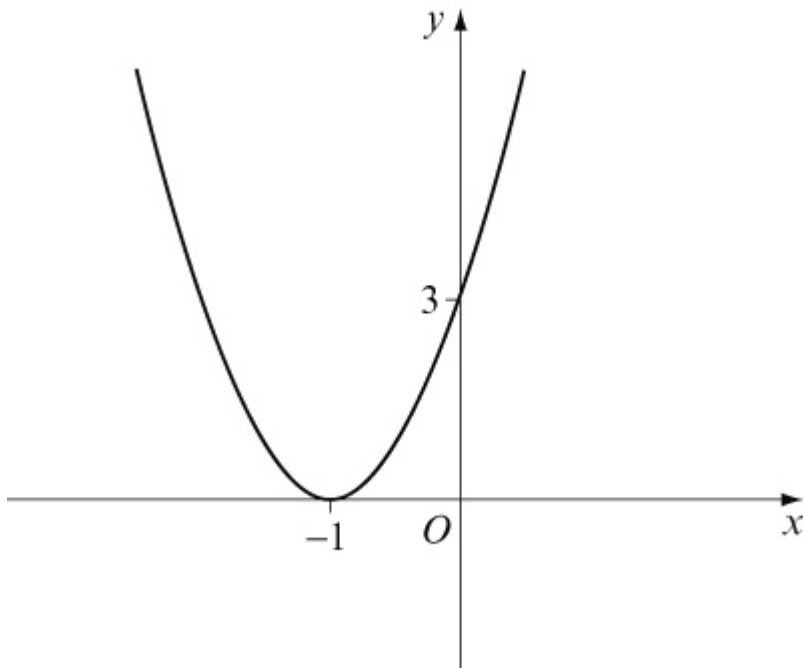

(c)  $y = \frac{1}{x}$

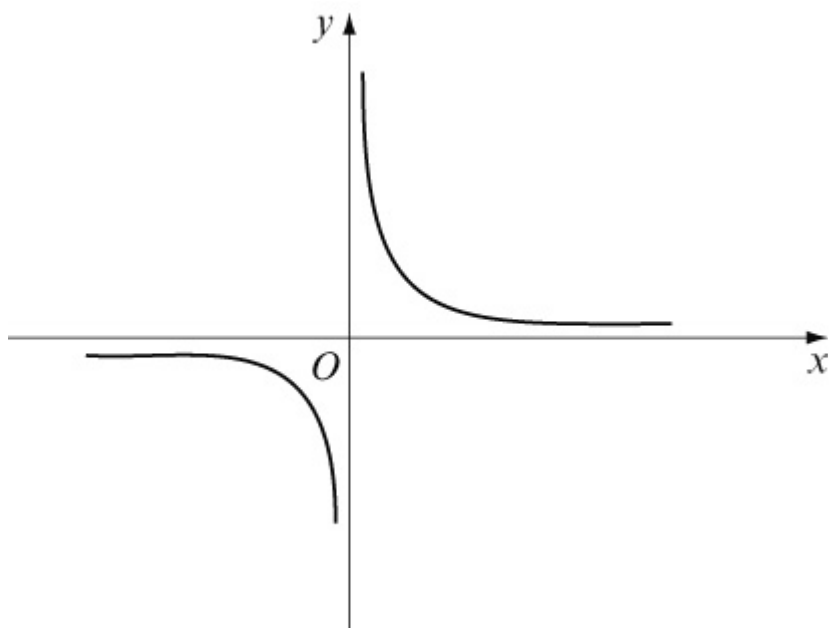

$$y = \frac{3}{x}. \text{ Vertical stretch, scale factor 3.}$$

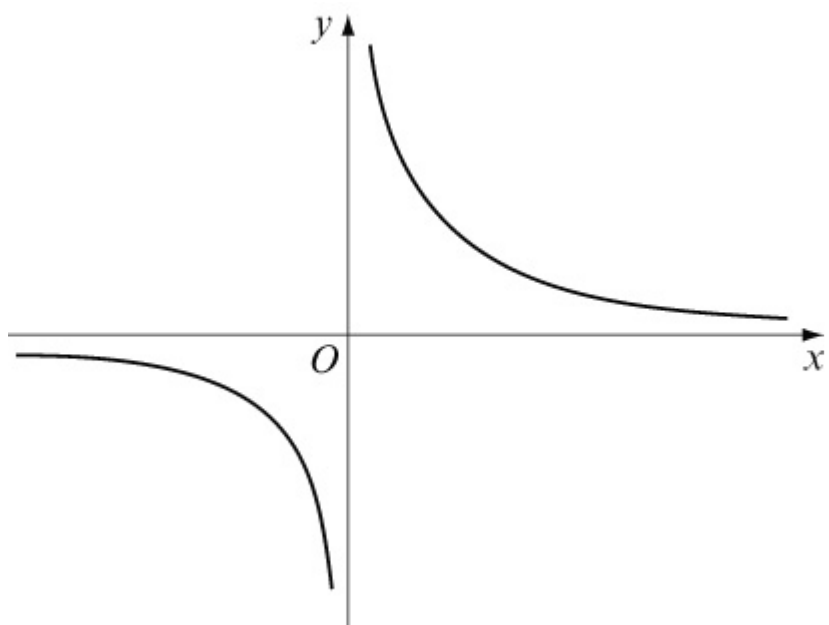

$$y = \frac{3}{x} - 2. \text{ Vertical translation of } -2.$$

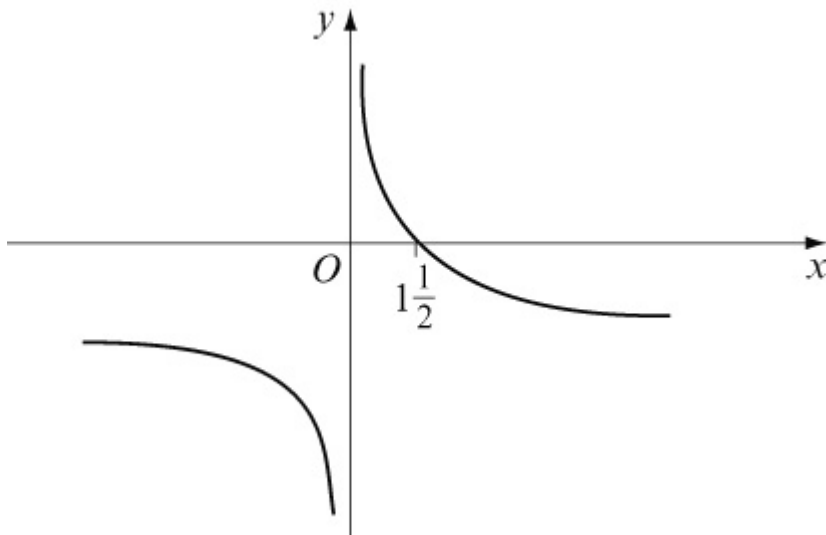

(d)  $y = \frac{1}{x}$

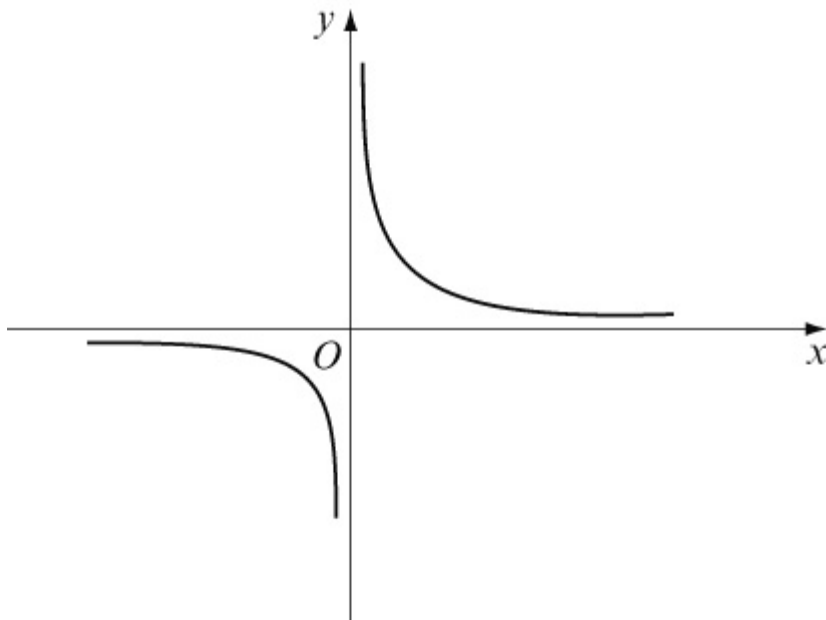

$y = \frac{1}{x-2}$ . Horizontal translation of +2.

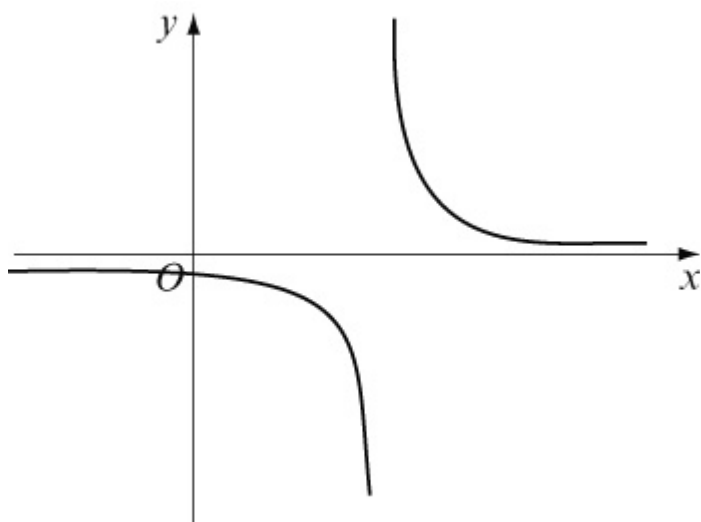

$y = \frac{3}{x-2}$ . Vertical stretch, scale factor 3.

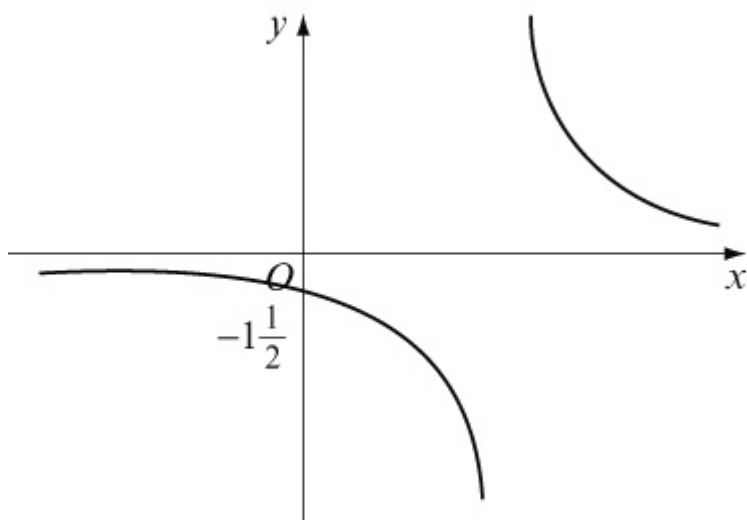

(e)  $y = \sin x$

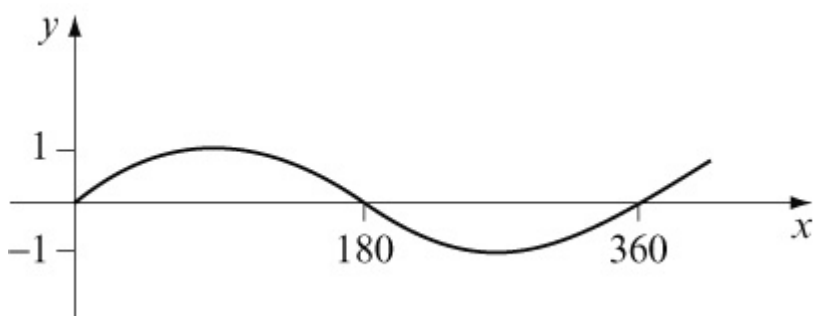

$y = \sin ( x + 30^\circ )$  . Horizontal translation of  $- 30^\circ$

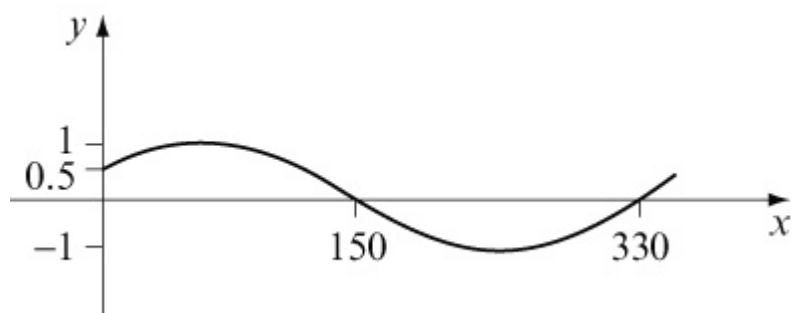

$y = 5 \sin ( x + 30 ^ \circ )$  . Vertical stretch, scale factor 5.

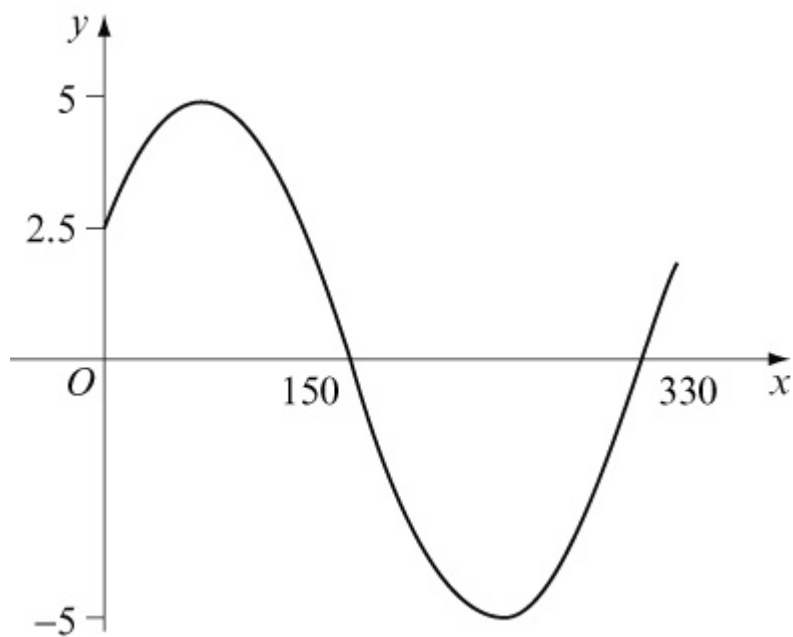

(f)  $y = e^x$

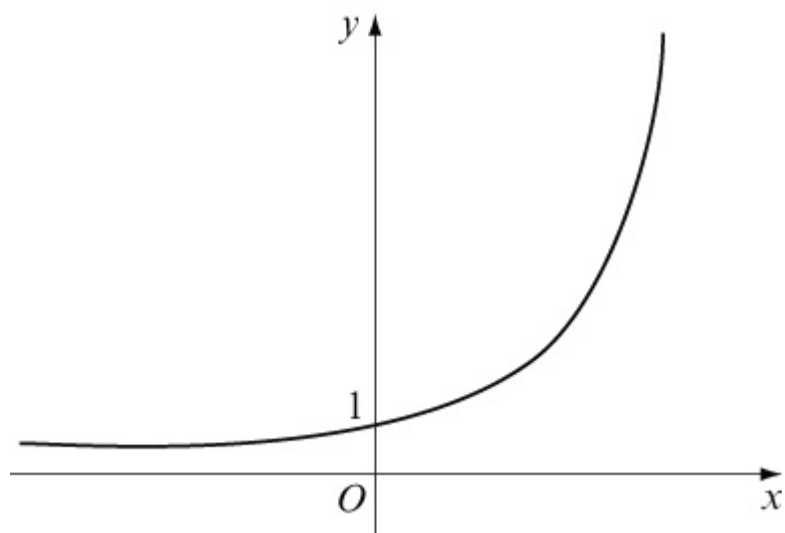

$y = \frac{1}{2} e^x$  . Vertical stretch, scale factor  $\frac{1}{2}$ .

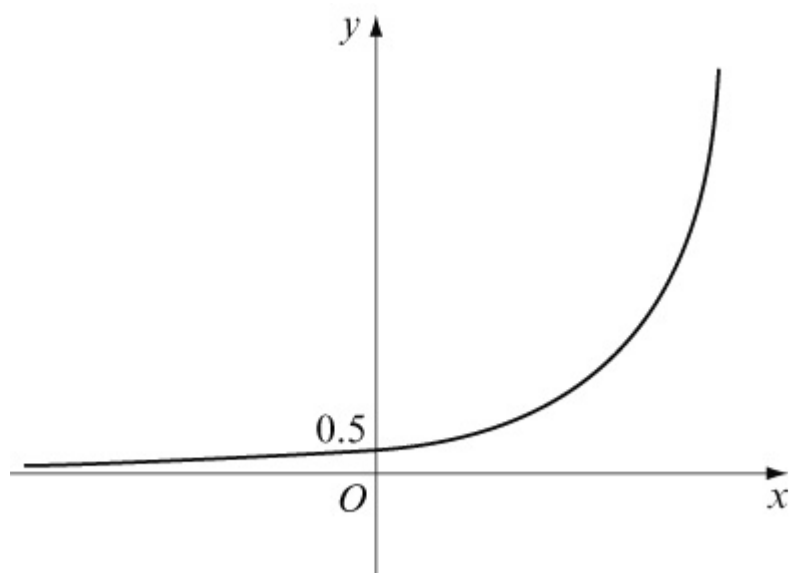

$y = \frac{1}{2}e^x + 4$ . Vertical translation of  $+4$ .

(When  $x = 0$ ,  $y = \frac{1}{2}e^0 + 4 = 4.5$ ).

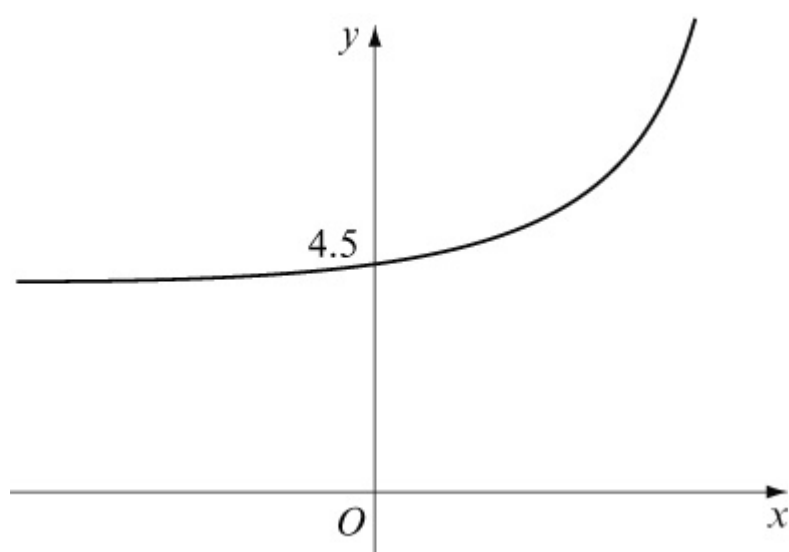

(g)  $y = 4x$



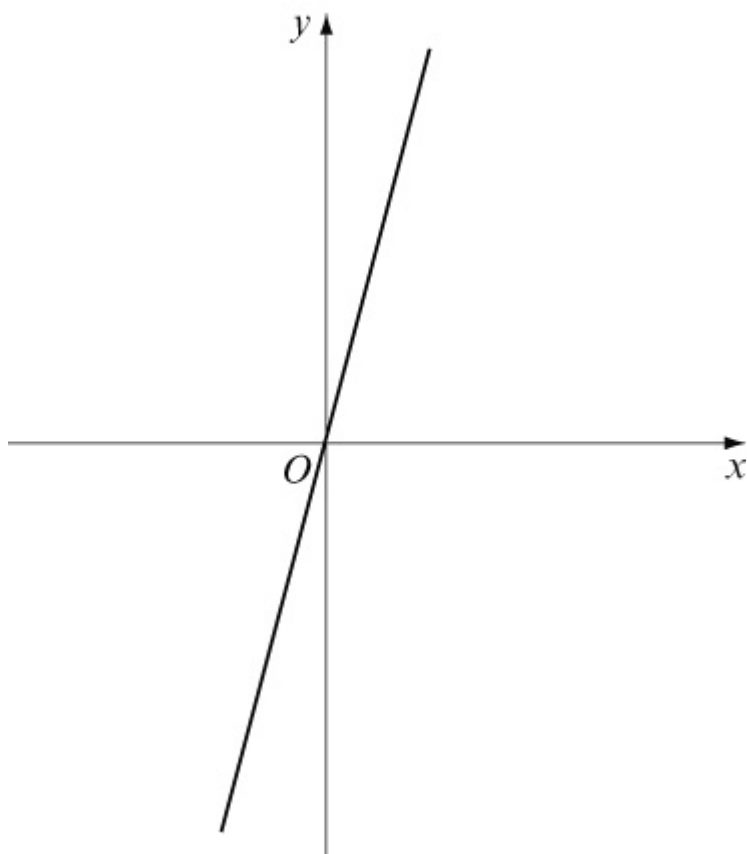

$y = |4x|$ . For the part below the  $x$ -axis, reflect in the  $x$ -axis.

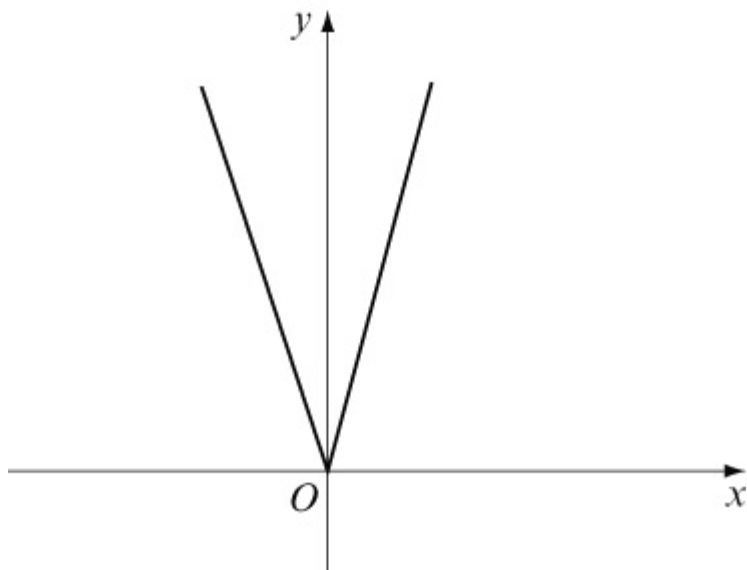

$y = |4x| + 1$ . Vertical translation of  $+1$ .

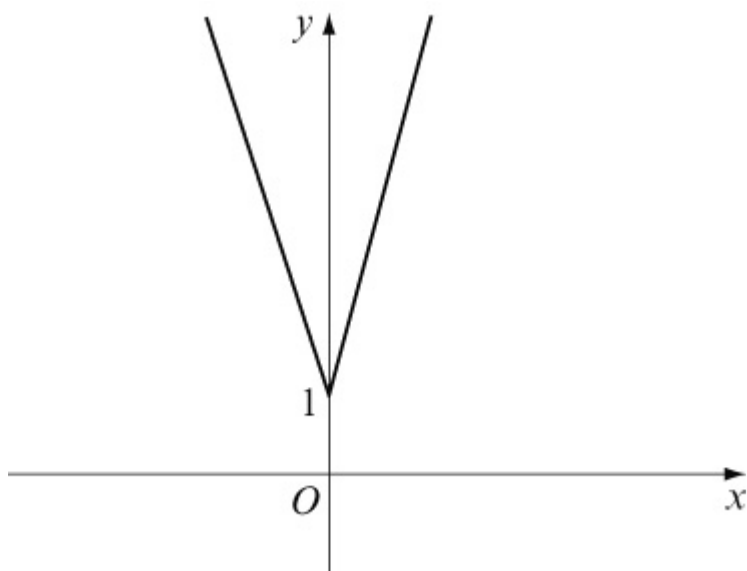

(h)  $y = x^3$

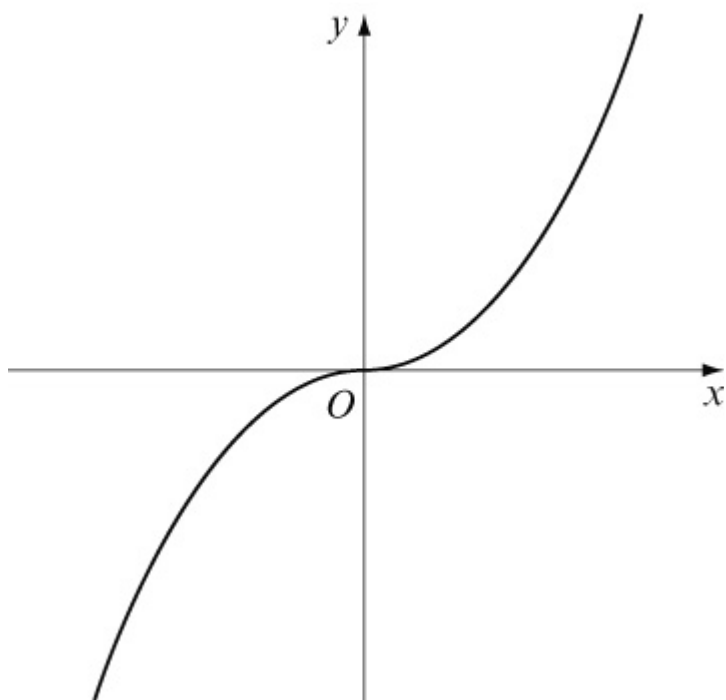

$y = 2x^3$ . Vertical stretch, scale factor 2.

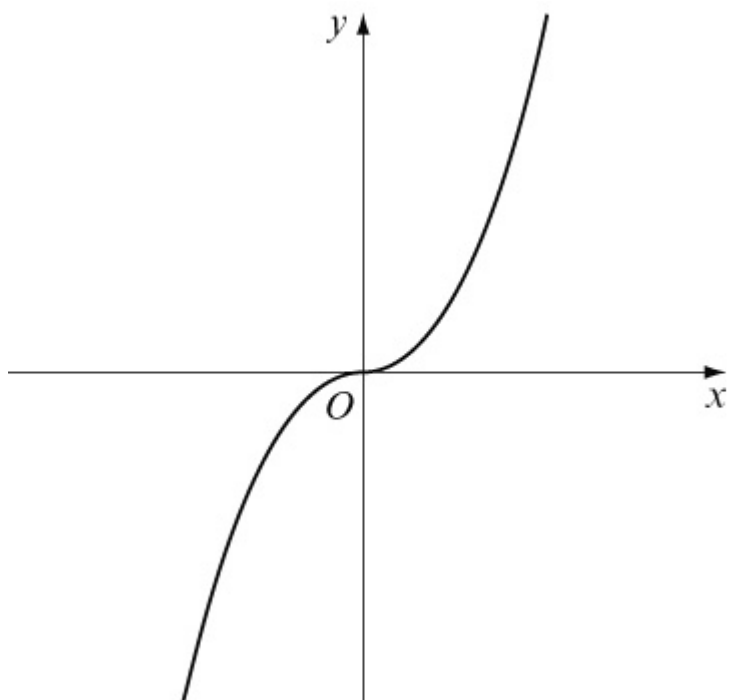

$y = 2x^3 - 3$ . Vertical translation of  $-3$ .

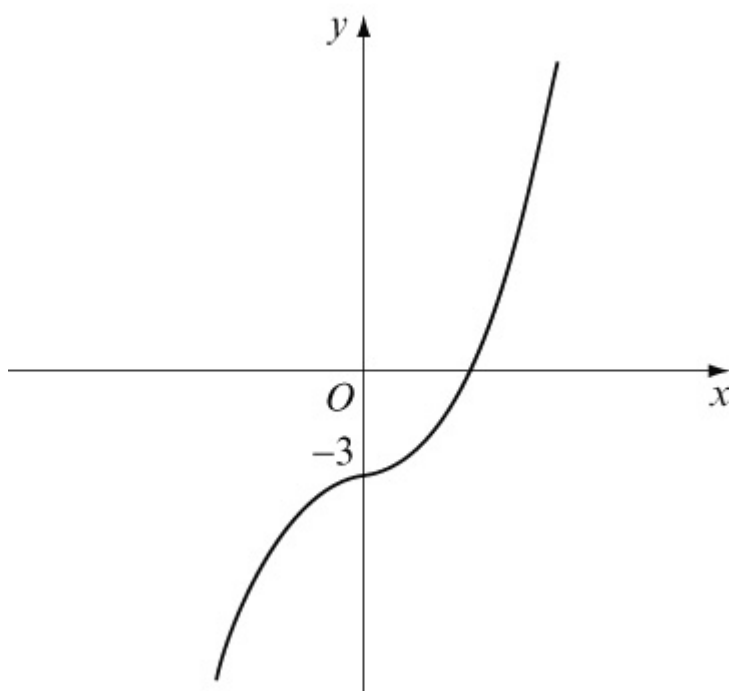

(i)  $y = \ln x$

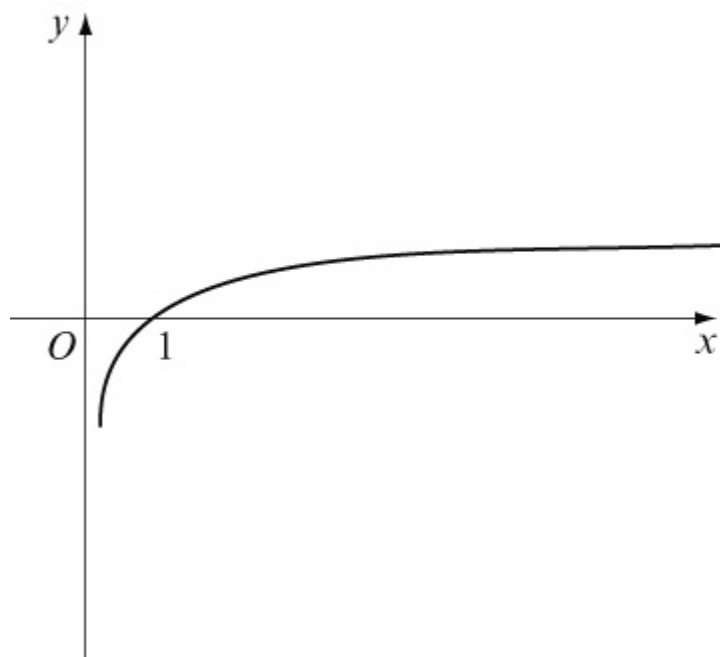

$y = \ln(x - 2)$  . Horizontal translation of +2.

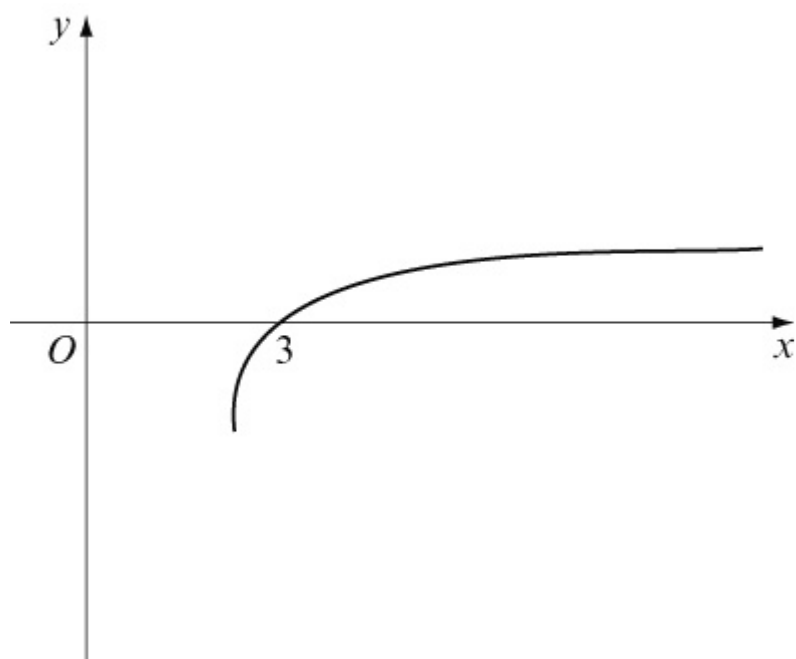

$y = 3 \ln(x - 2)$  . Vertical stretch, scale factor 3.

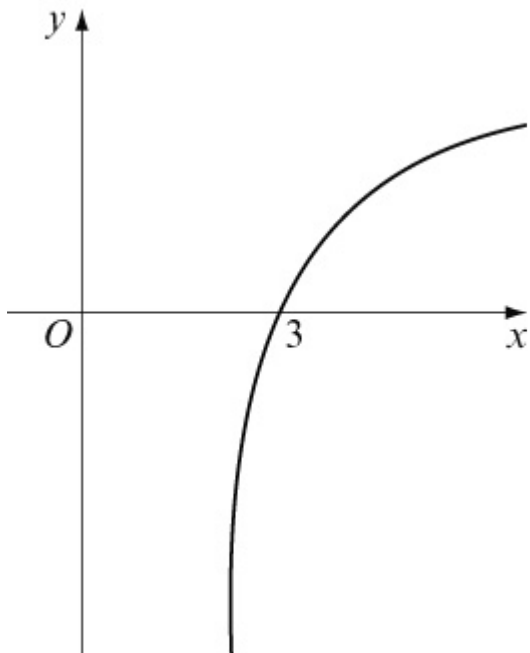

(i)  $y = e^x$

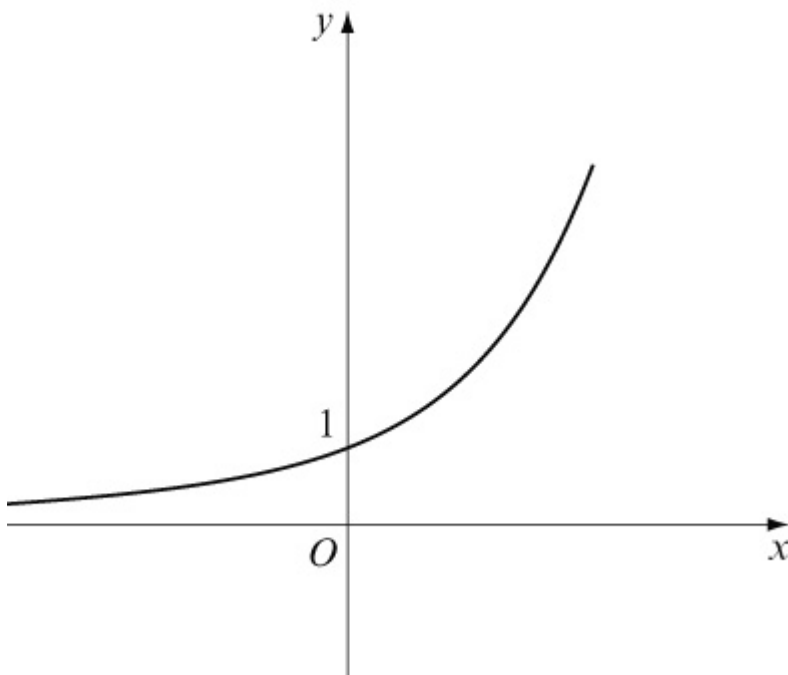

$y = 2e^x$ . Vertical stretch, scale factor 2.

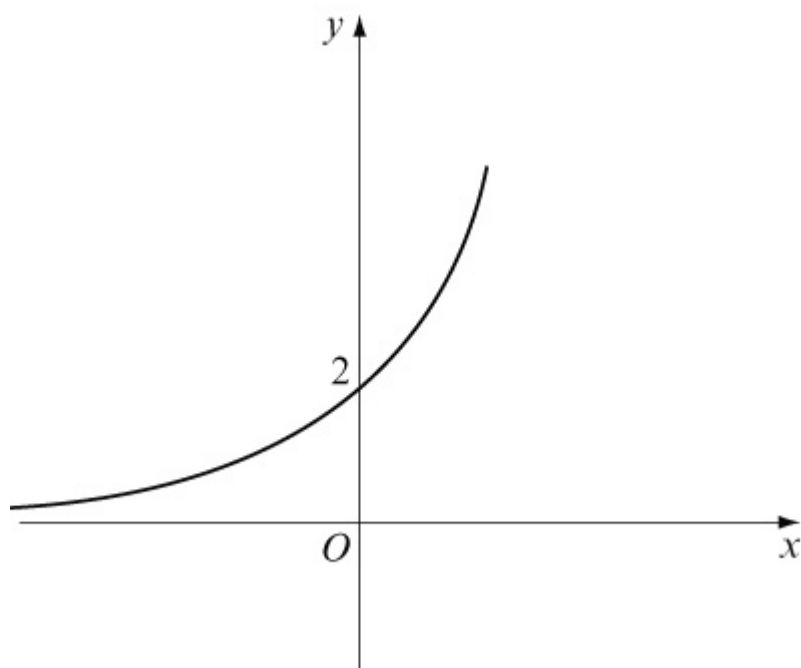

$y = 2e^x - 3$ . Vertical translation of  $-3$ .

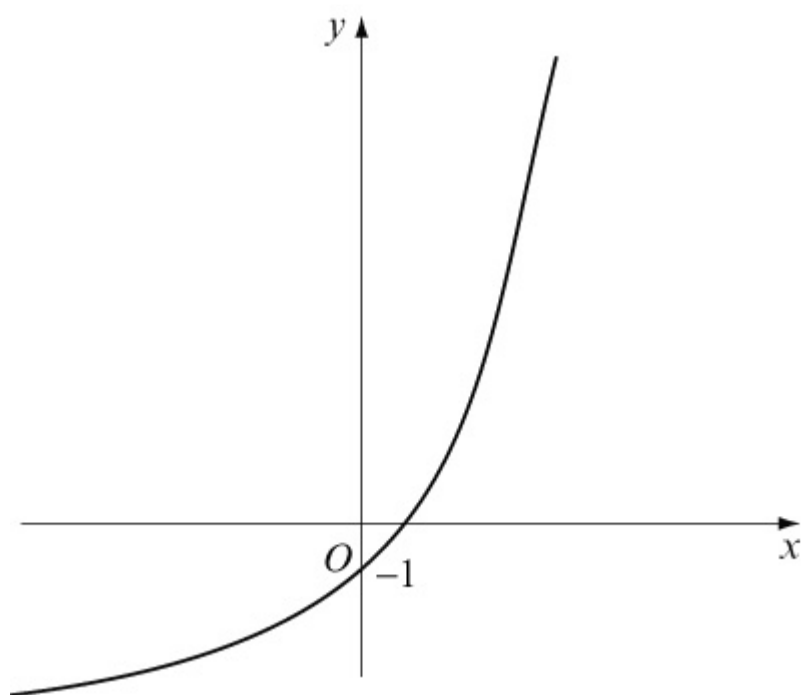

$y = |2e^x - 3|$ . For the part below the  $x$ -axis, reflect in the  $x$ -axis.

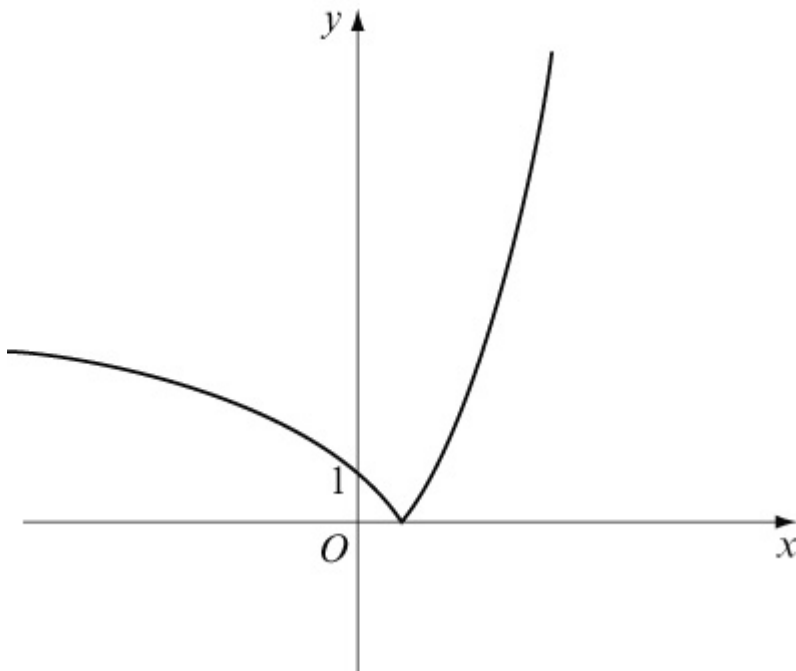

© Pearson Education Ltd 2008

# Solutionbank

## Edexcel AS and A Level Modular Mathematics

### Exercise E, Question 1

#### Question:

The diagram shows a sketch of the graph of  $y = f(x)$ .

The curve passes through the origin  $O$ , the point  $A(-2, -2)$  and the point  $B(3, 4)$ .

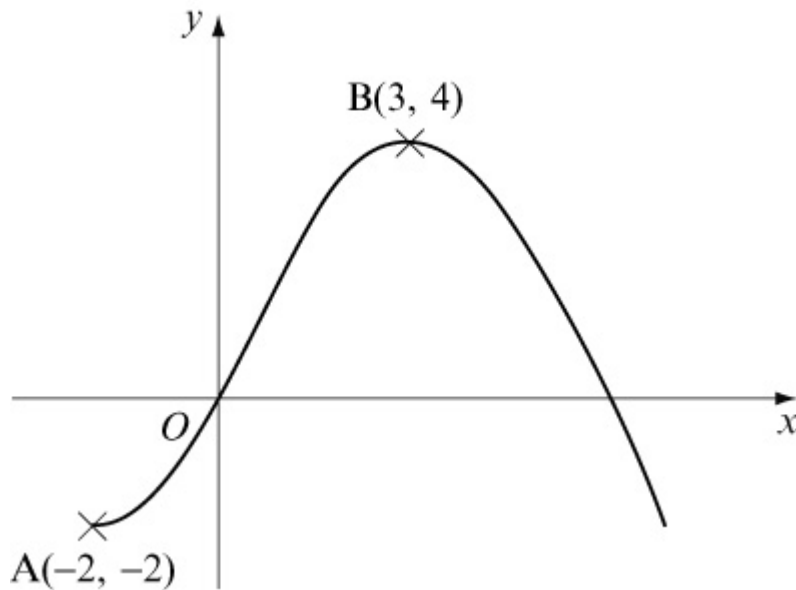

Sketch the graph of:

(a)  $y = 3f(x) + 2$

(b)  $y = f(x - 2) - 5$

(c)  $y = \frac{1}{2}f(x + 1)$

(d)  $y = -f(2x)$

In each case, find the coordinates of the images of the points  $O$ ,  $A$  and  $B$ .

#### Solution:

(a)  $y = 3f(x)$ . Vertical stretch, scale factor 3.



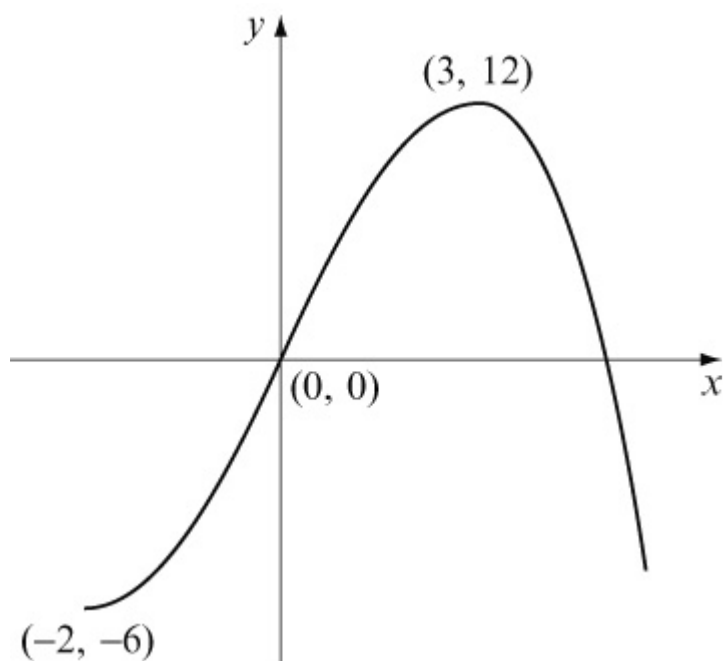

$y = 3f(x) + 2$ . Vertical translation of +2.

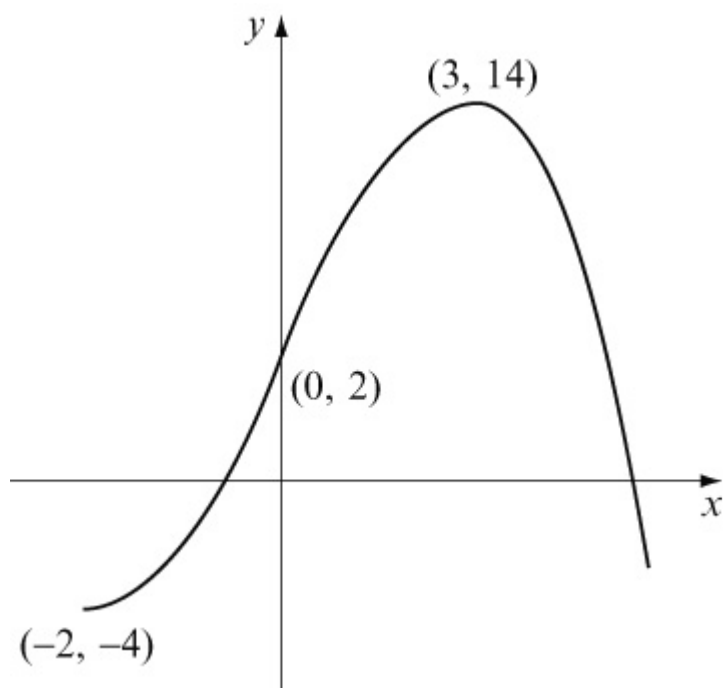

(b)  $y = f(x - 2)$ . Horizontal translation of +2.

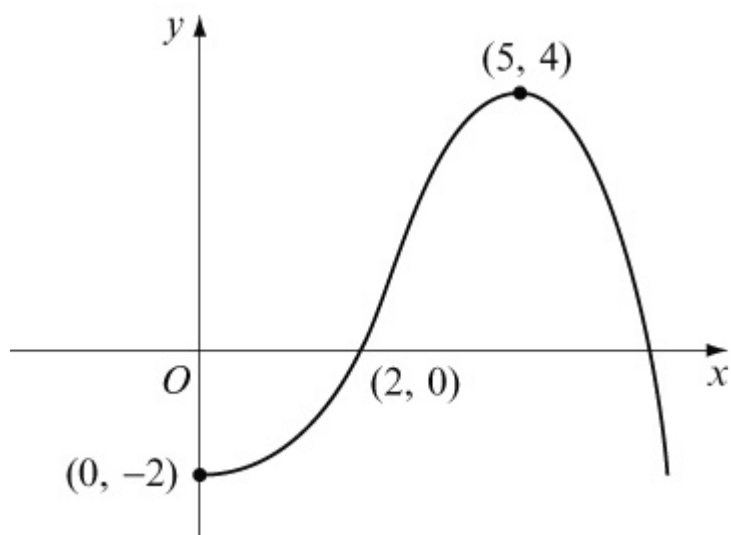

$y = f(x - 2) - 5$ . Vertical translation of  $-5$ .

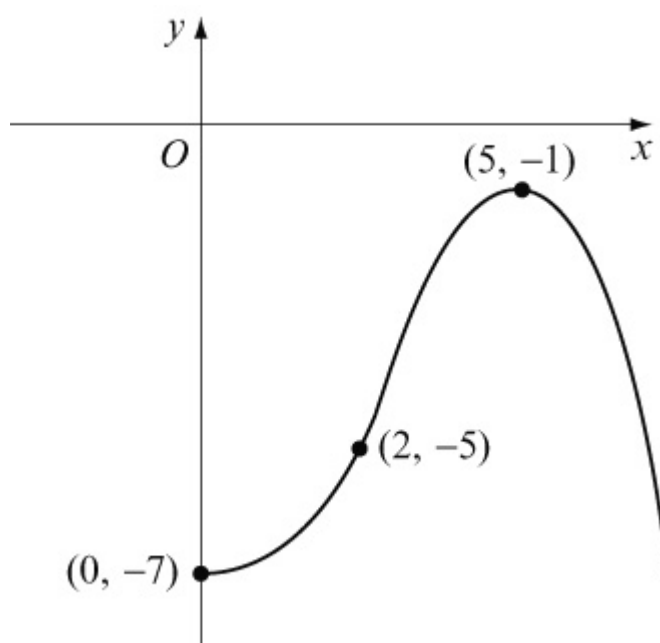

(c)  $y = f(x + 1)$ . Horizontal translation of  $-1$ .

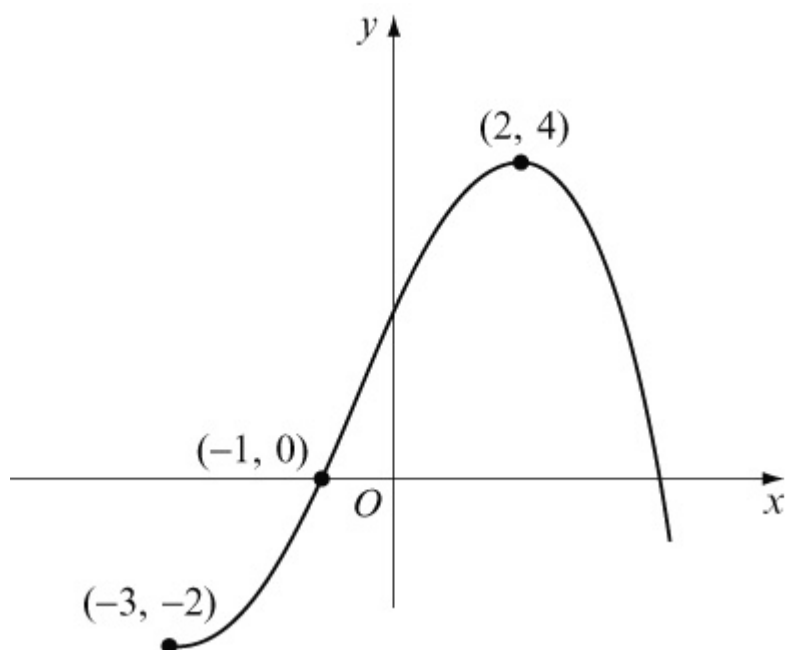

$y = \frac{1}{2}f(x + 1)$  . Vertical stretch, scale factor  $\frac{1}{2}$ .

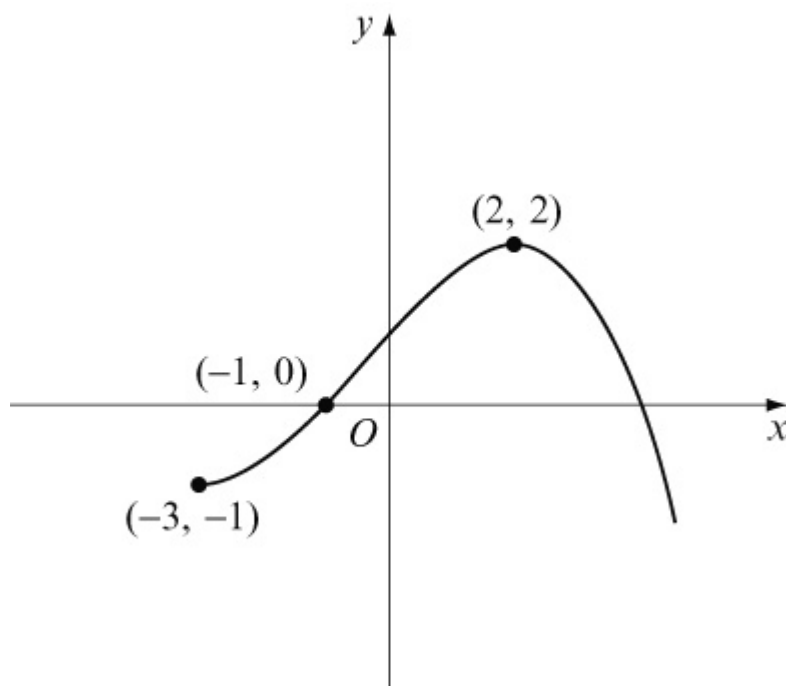

(d)  $y = f(2x)$  . Horizontal stretch, scale factor  $\frac{1}{2}$ .

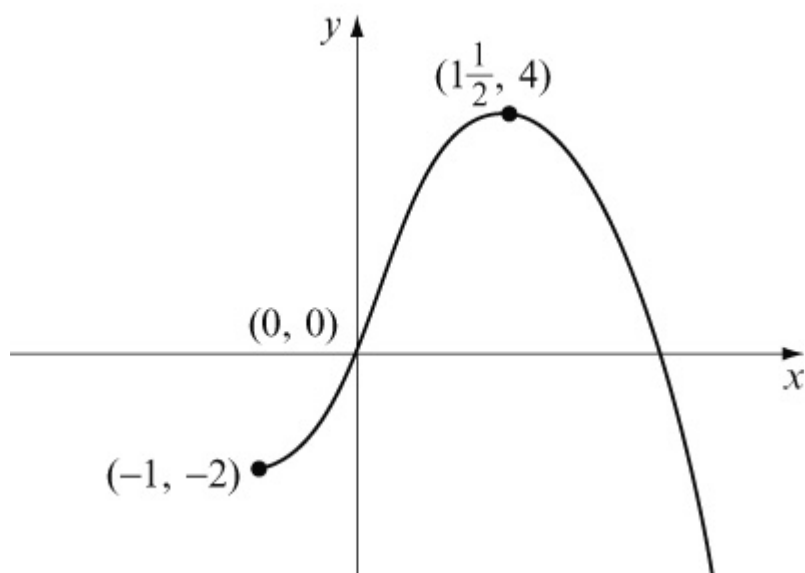

$y = -f(2x)$ . Reflection in the  $x$ -axis.  
(Vertical stretch, scale factor  $-1$ ).

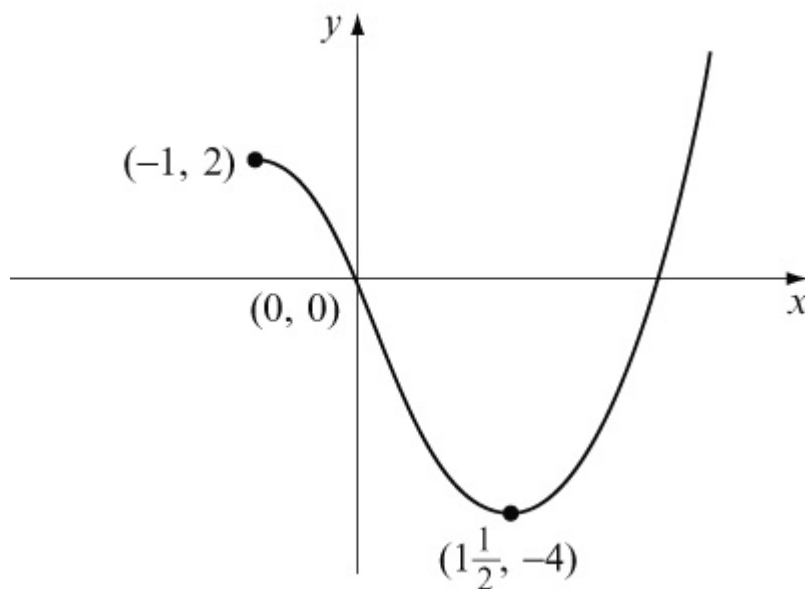

# Solutionbank

## Edexcel AS and A Level Modular Mathematics

### Exercise E, Question 2

#### Question:

The diagram shows a sketch of the graph of  $y = f(x)$ . The curve has a maximum at the point  $A(-1, 4)$  and crosses the axes at the points  $B(0, 3)$  and  $C(-2, 0)$ .

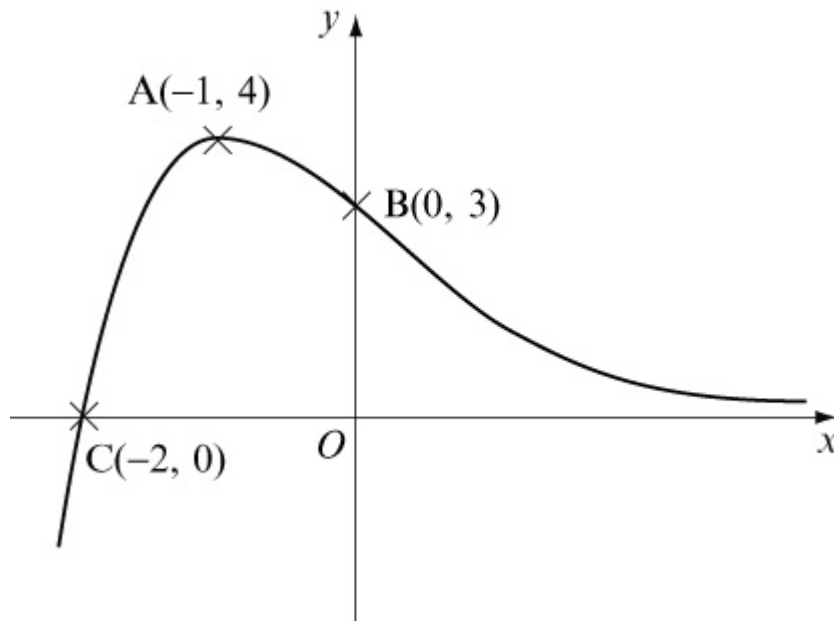

Sketch the graph of:

(a)  $y = 3f(x - 2)$

(b)  $y = \frac{1}{2}f\left(\frac{1}{2}x\right)$

(c)  $y = -f(x) + 4$

(d)  $y = -2f(x + 1)$

For each graph, find, where possible, the coordinates of the maximum or minimum and the coordinates of the intersection points with the axes.

#### Solution:

(a)  $y = f(x - 2)$ . Horizontal translation of  $+2$ .

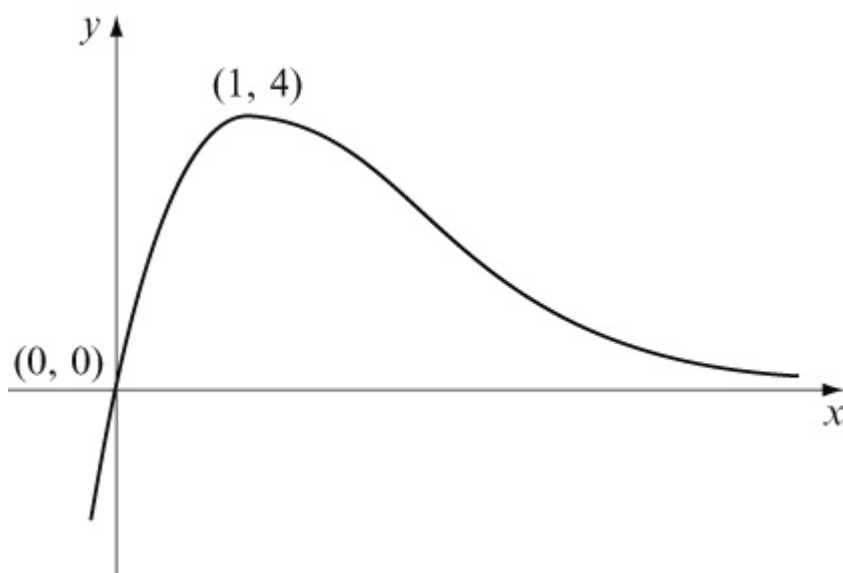

$y = 3f(x - 2)$  . Vertical stretch, scale factor 3.

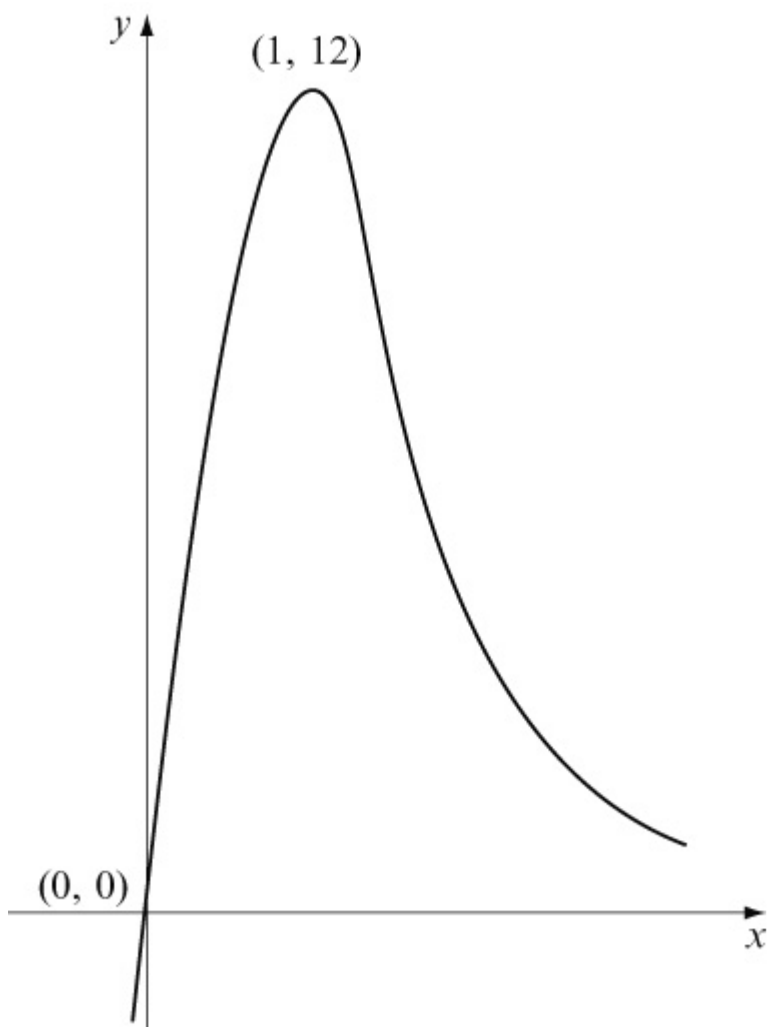

(b)  $y = f\left(\frac{1}{2}x\right)$  . Horizontal stretch, scale factor 2.

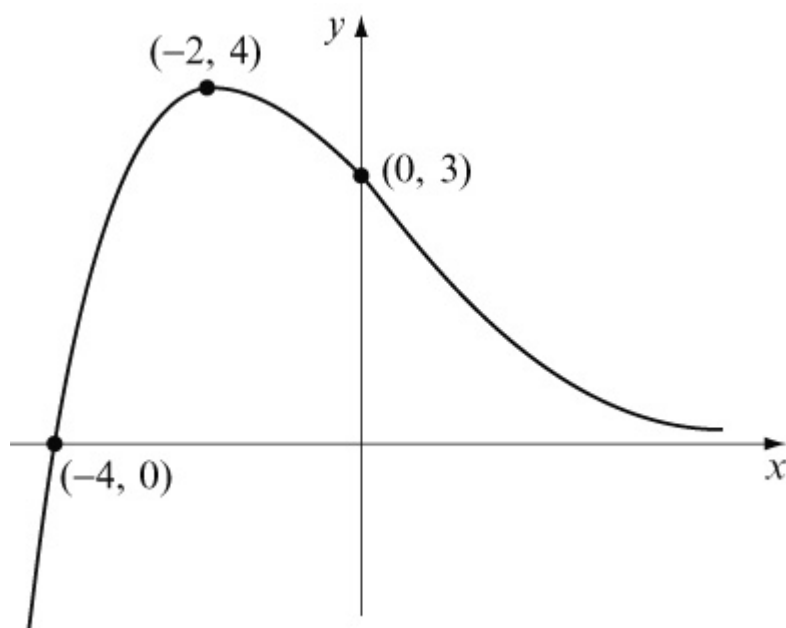

$$y = \frac{1}{2}f\left(\frac{1}{2}x\right). \text{ Vertical stretch, scale factor } \frac{1}{2}.$$

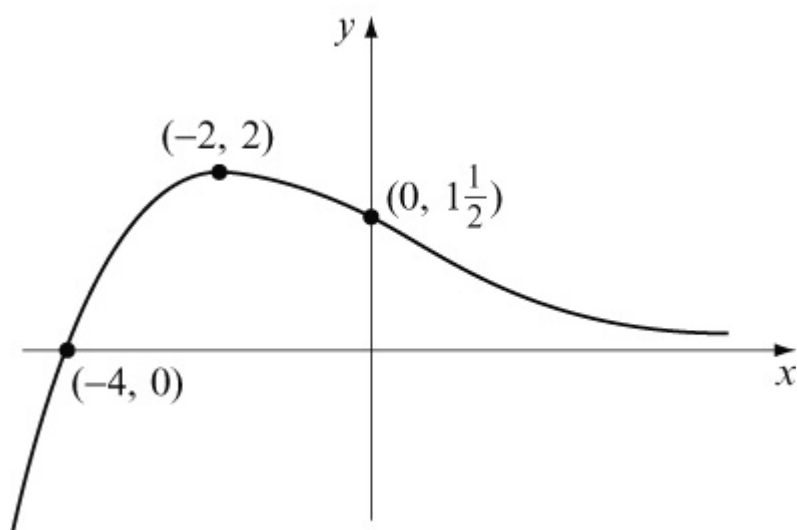

$$(c) y = -f(x). \text{ Reflection in the } x\text{-axis. (Vertical stretch, scale factor } -1).$$

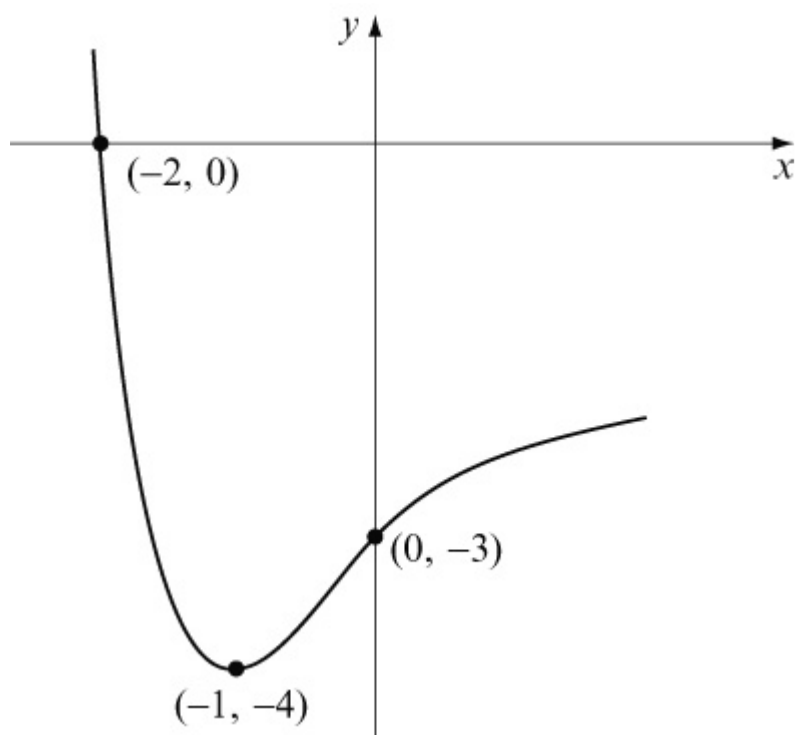

$y = -f(x) + 4$ . Vertical translation of  $+4$ .

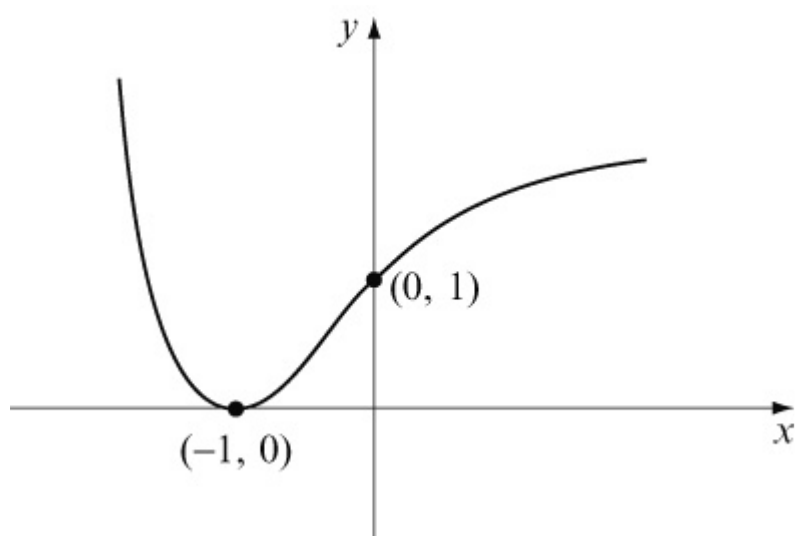

(d)  $y = f(x + 1)$ . Horizontal translation of  $-1$ .

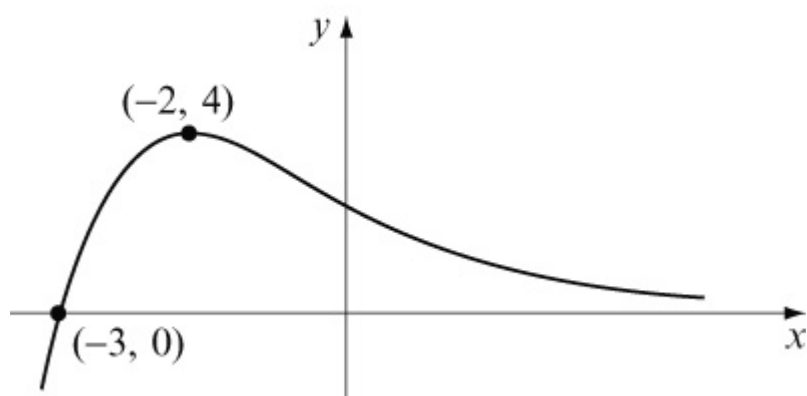



$$y = -2f(x + 1)$$

Reflection in the  $x$ -axis, and vertical stretch, scale factor 2.

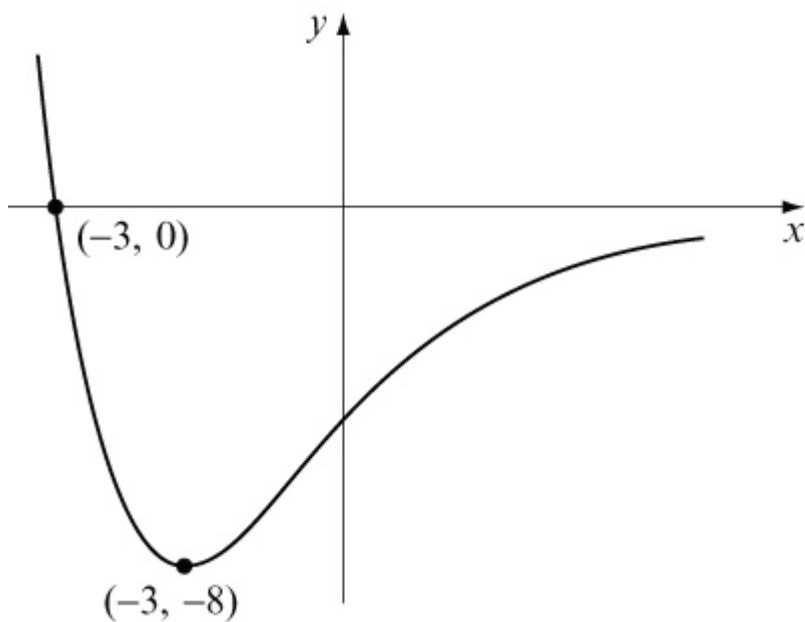

© Pearson Education Ltd 2008

# Solutionbank

## Edexcel AS and A Level Modular Mathematics

Exercise E, Question 3

### Question:

The diagram shows a sketch of the graph of  $y = f(x)$ . The lines  $x = 2$  and  $y = 0$  (the  $x$ -axis) are asymptotes to the curve.

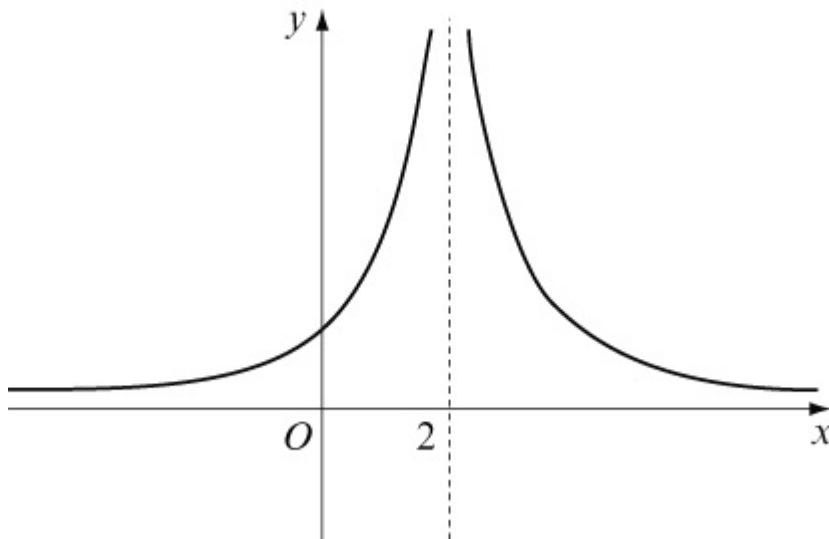

Sketch the graph of:

(a)  $y = 3f(x) - 1$

(b)  $y = f(x + 2) + 4$

(c)  $y = -f(2x)$

For each part, state the equations of the asymptotes.

### Solution:

(a)  $y = 3f(x)$ . Vertical stretch, scale factor 3.

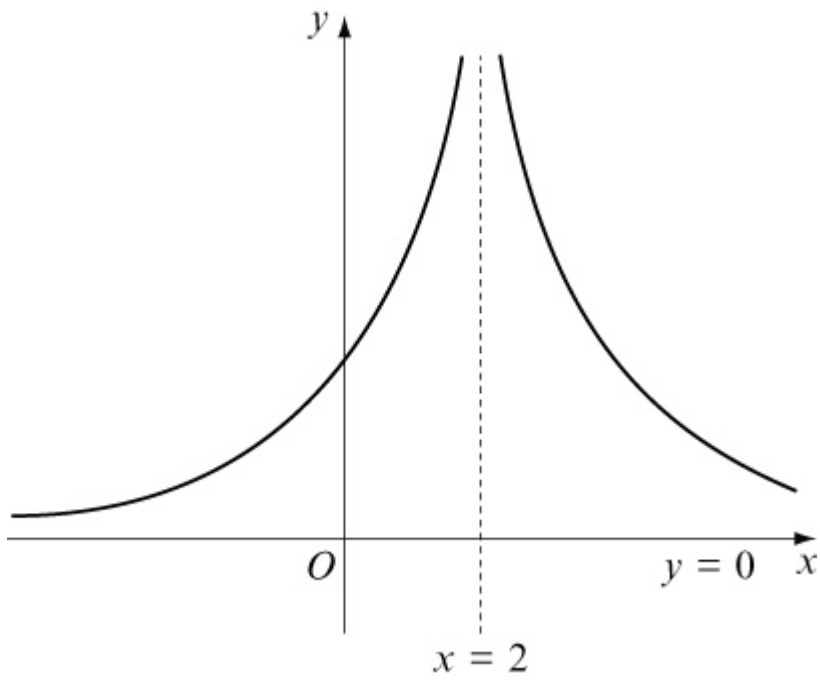

$y = 3f(x) - 1$ . Vertical translation of  $-1$ .

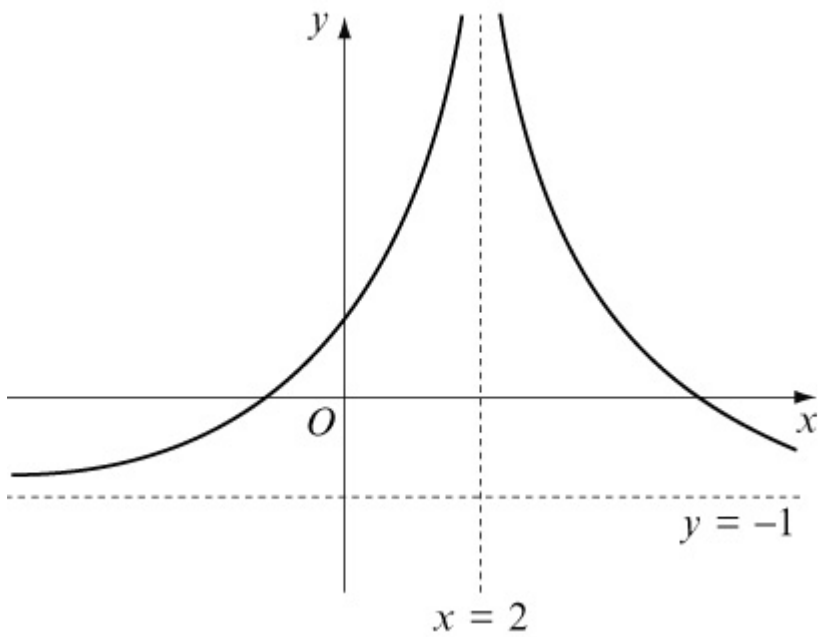

Asymptotes:  $x = 2$ ,  $y = -1$

(b)  $y = f(x + 2)$ . Horizontal translation of  $-2$ .

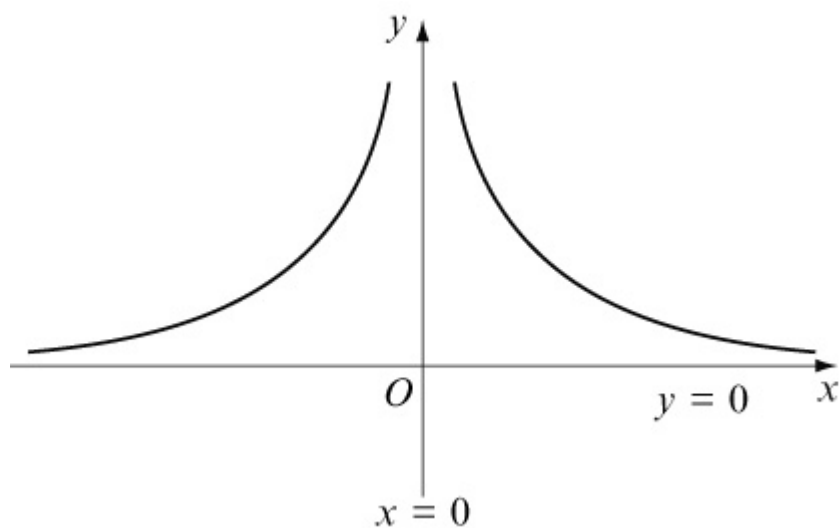

$y = f(x + 2) + 4$ . Vertical translation of +4.

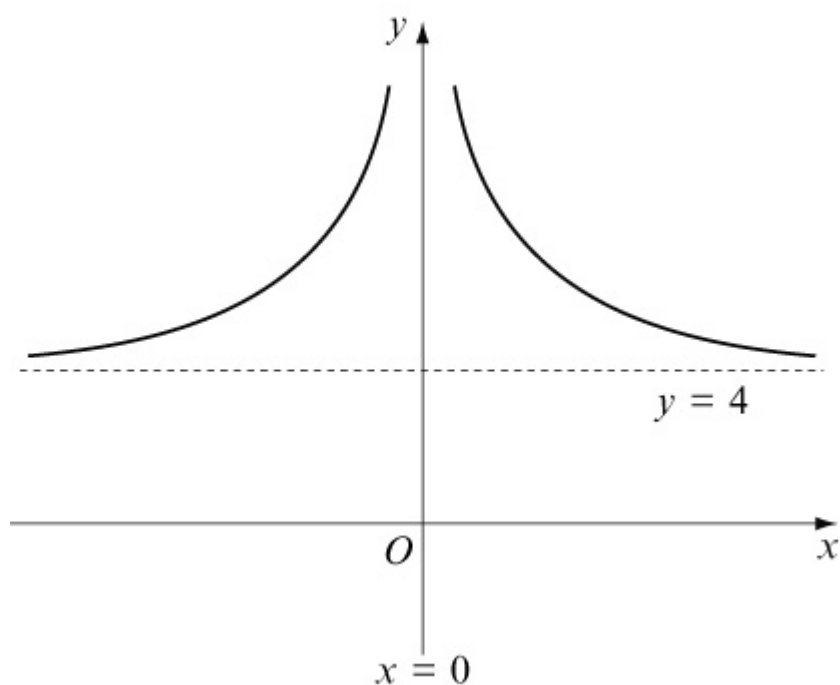

Asymptotes:  $x = 0$ ,  $y = 4$

(c)  $y = f(2x)$ . Horizontal stretch, scale factor  $\frac{1}{2}$ .

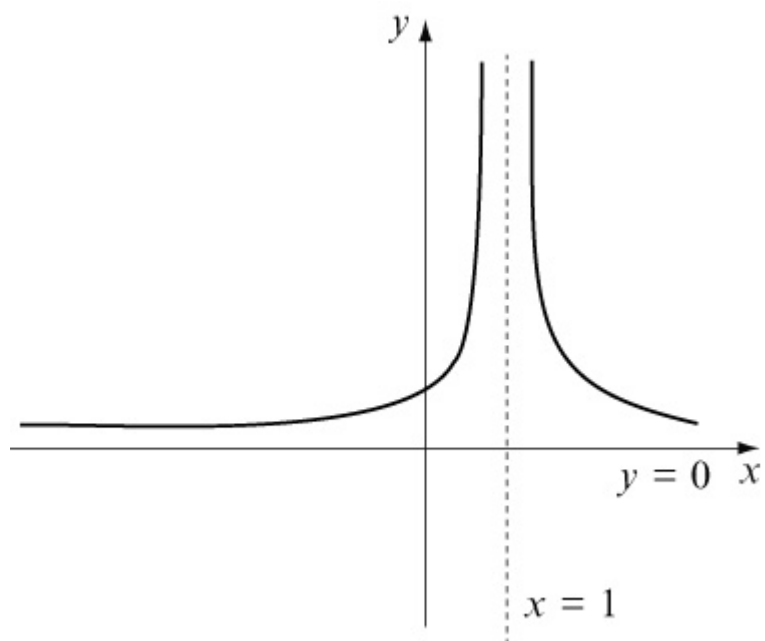

$y = -f(2x)$  . Reflection in the  $x$ -axis.

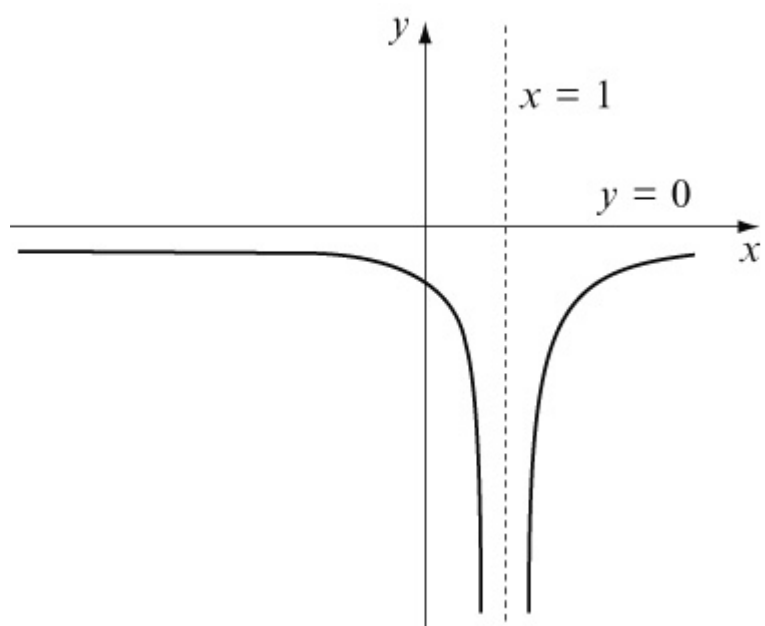

Asymptotes:  $x = 1$  ,  $y = 0$

# Solutionbank

## Edexcel AS and A Level Modular Mathematics

### Exercise F, Question 1

#### Question:

- (a) Using the same scales and the same axes, sketch the graphs of  $y = |2x|$  and  $y = |x - a|$ , where  $a > 0$ .
- (b) Write down the coordinates of the points where the graph of  $y = |x - a|$  meets the axes.
- (c) Show that the point with coordinates  $(-a, 2a)$  lies on both graphs.
- (d) Find the coordinates, in terms of  $a$ , of a second point which lies on both graphs.

[E]

#### Solution:

(a)

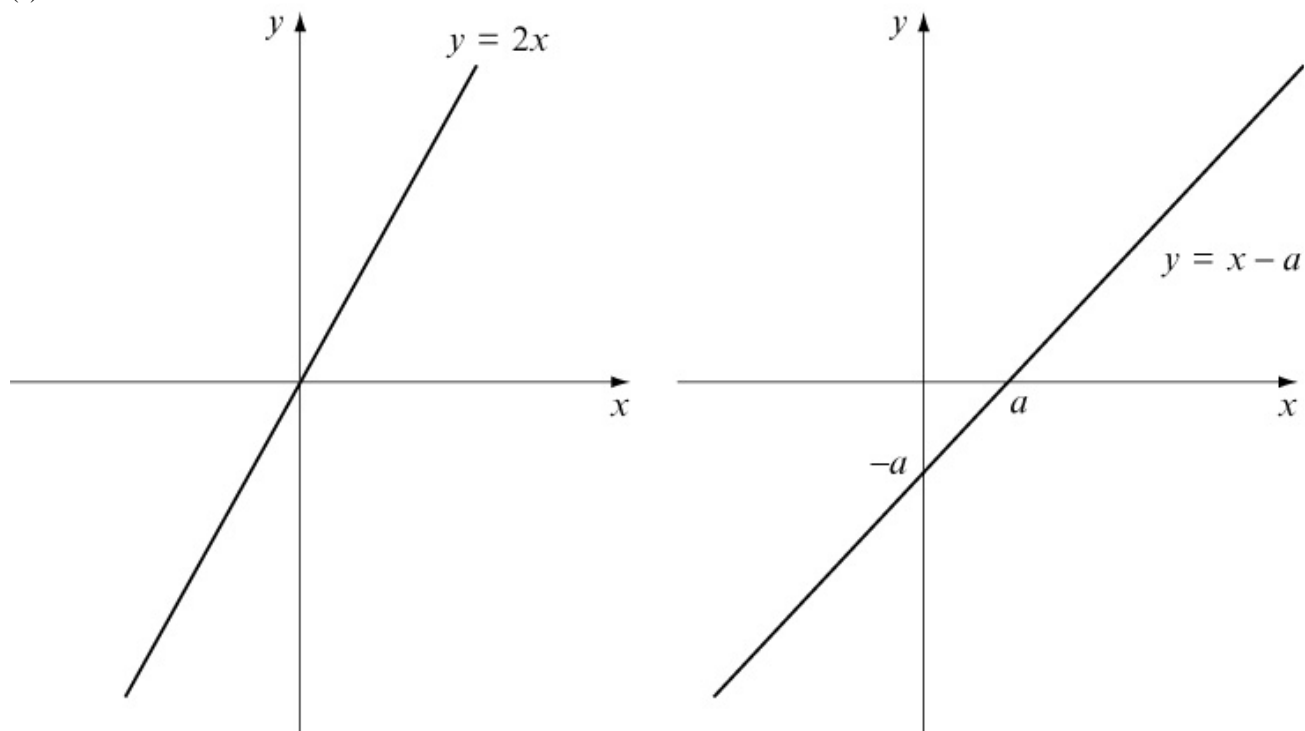

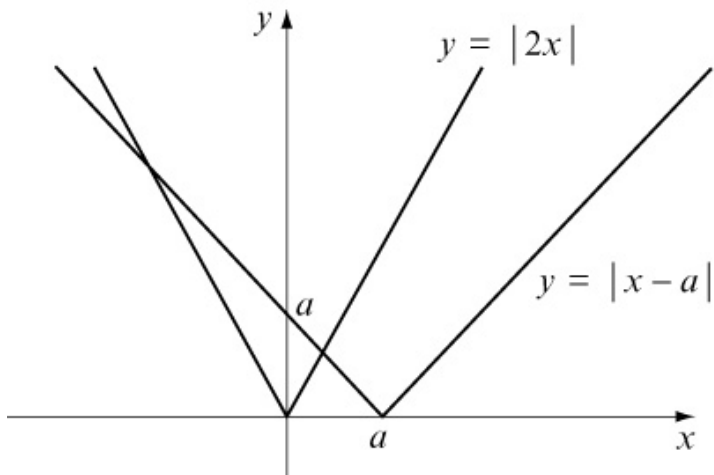

(b) For  $y = |x - a|$  :

$$\text{When } x = 0, y = |-a| = a \quad (0, a)$$

$$\text{When } y = 0, x - a = 0 \Rightarrow x = a \quad (a, 0)$$

(c) For  $y = |2x|$  :

$$\text{When } x = -a, y = |-2a| = 2a$$

So  $(-a, 2a)$  lies on  $y = |2x|$  .

For  $y = |x - a|$  :

$$\text{When } x = -a, y = |-a - a| = |-2a| = 2a$$

So  $(-a, 2a)$  lies on  $y = |x - a|$  .

(d) The other intersection point is on the reflected part of  $y = x - a$  .

$$2x = -(x - a)$$

$$2x = -x + a$$

$$3x = a$$

$$x = \frac{a}{3}$$

$$\text{When } x = \frac{a}{3}, y = \left| \frac{2a}{3} \right| = \frac{2a}{3}$$

$\left( \frac{a}{3}, \frac{2a}{3} \right)$  lies on both graphs.

# Solutionbank

## Edexcel AS and A Level Modular Mathematics

### Exercise F, Question 2

#### Question:

- (a) Sketch, on a single diagram, the graphs of  $y = a^2 - x^2$  and  $y = |x + a|$ , where  $a$  is a constant and  $a > 1$ .
- (b) Write down the coordinates of the points where the graph of  $y = a^2 - x^2$  cuts the coordinate axes.
- (c) Given that the two graphs intersect at  $x = 4$ , calculate the value of  $a$ .

[E]

#### Solution:

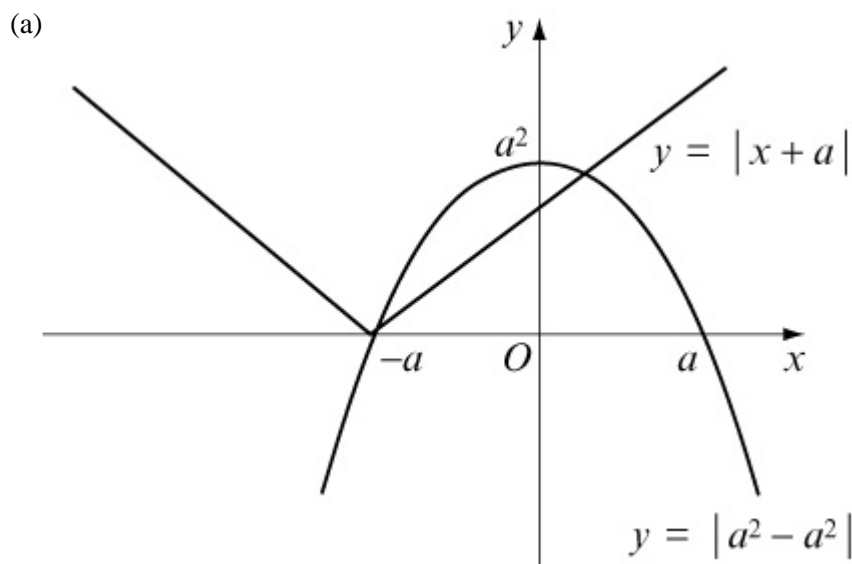

- (b) For  $y = a^2 - x^2$ :  
 When  $x = 0$ ,  $y = a^2$      $(0, a^2)$   
 When  $y = 0$ ,  $a^2 - x^2 = 0$   
 $\Rightarrow x^2 = a^2$   
 $\Rightarrow x = \pm a$      $(-a, 0)$  and  $(a, 0)$

- (c) The graphs intersect on the non-reflected part of  $y = x + a$ .

$$a^2 - x^2 = x + a$$

Given that  $x = 4$ :

$$a^2 - 4^2 = 4 + a$$

$$a^2 - a - 20 = 0$$



$$(a - 5)(a + 4) = 0$$

Since  $a > 1$ ,  $a = 5$

© Pearson Education Ltd 2008

# Solutionbank

## Edexcel AS and A Level Modular Mathematics

### Exercise F, Question 3

#### Question:

- (a) On the same axes, sketch the graphs of  $y = 2 - x$  and  $y = 2|x + 1|$ .
- (b) Hence, or otherwise, find the values of  $x$  for which  $2 - x = 2|x + 1|$ .

[E]

#### Solution:

(a)

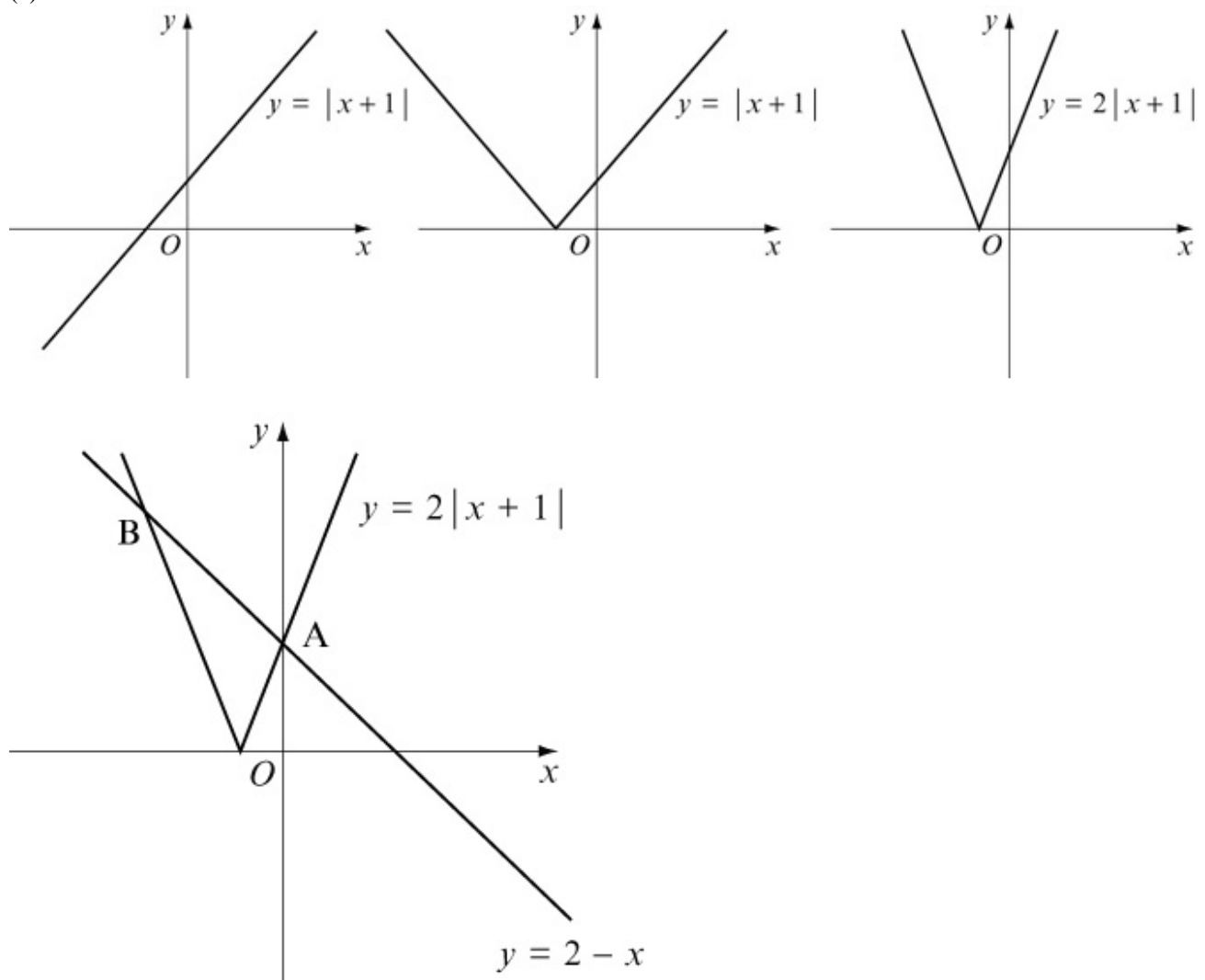

(b) Intersection point A:

$$2(x + 1) = 2 - x$$

$$2x + 2 = 2 - x$$

$$3x = 0$$

$$x = 0$$

Intersection point B is on the reflected part of the modulus graph.

$$\begin{aligned} -2(x + 1) &= 2 - x \\ -2x - 2 &= 2 - x \\ -x &= 4 \\ x &= -4 \end{aligned}$$

© Pearson Education Ltd 2008

# Solutionbank

## Edexcel AS and A Level Modular Mathematics

### Exercise F, Question 4

#### Question:

Functions  $f$  and  $g$  are defined by

$$f : x \rightarrow 4 - x \quad \{ x \in \mathbb{R} \}$$

$$g : x \rightarrow 3x^2 \quad \{ x \in \mathbb{R} \}$$

- (a) Find the range of  $g$ .
- (b) Solve  $gf(x) = 48$ .
- (c) Sketch the graph of  $y = |f(x)|$  and hence find the values of  $x$  for which  $|f(x)| = 2$ .

[E]

#### Solution:

(a)  $g(x) = 3x^2$

Since  $x^2 \geq 0$  for all  $x \in \mathbb{R}$ , the range of  $g(x)$  is  $g(x) \geq 0$

(b)  $gf(x) = 48$

$$gf(x) = g(4 - x) = 3(4 - x)^2$$

$$3(4 - x)^2 = 48$$

$$(4 - x)^2 = 16$$

Either  $4 - x = 4$  or  $4 - x = -4$

So  $x = 0$  or  $x = 8$

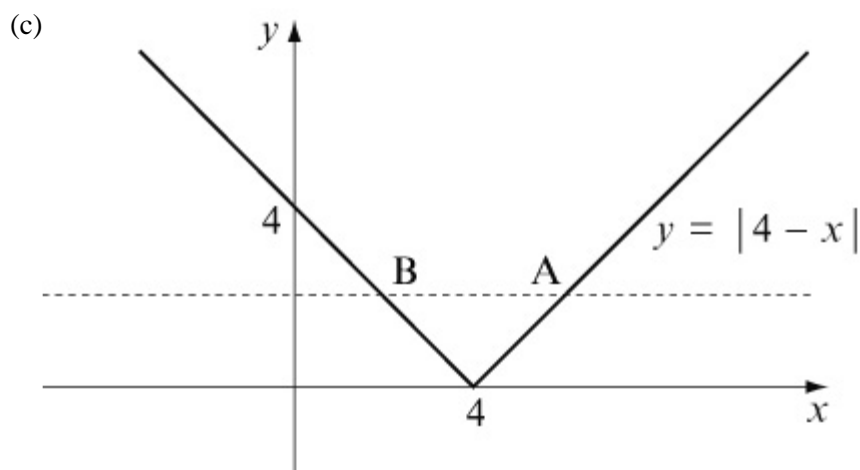

When  $|f(x)| = 2$ ,  $x = 2$  or  $x = 6$  (from symmetry of graph).

**[Or:**

$$\text{At A: } -(4 - x) = 2 \Rightarrow -4 + x = 2 \Rightarrow x = 6$$

$$\text{At B: } 4 - x = 2 \Rightarrow x = 2]$$

© Pearson Education Ltd 2008

# Solutionbank

## Edexcel AS and A Level Modular Mathematics

### Exercise F, Question 5

#### Question:

The function  $f$  is defined by  $f : x \rightarrow |2x - a| \quad \{x \in \mathbb{R}\}$ , where  $a$  is a positive constant.

(a) Sketch the graph of  $y = f(x)$ , showing the coordinates of the points where the graph cuts the axes.

(b) On a separate diagram, sketch the graph of  $y = f(2x)$ , showing the coordinates of the points where the graph cuts the axes.

(c) Given that a solution of the equation  $f(x) = \frac{1}{2}x$  is  $x = 4$ , find the two possible values of  $a$ .

[E]

#### Solution:

(a)

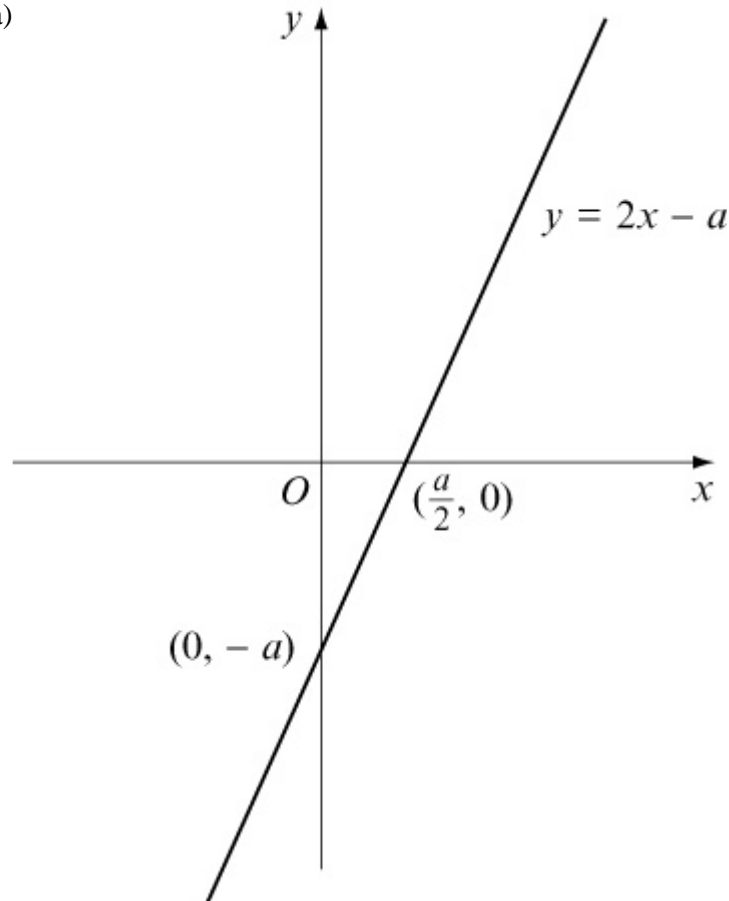

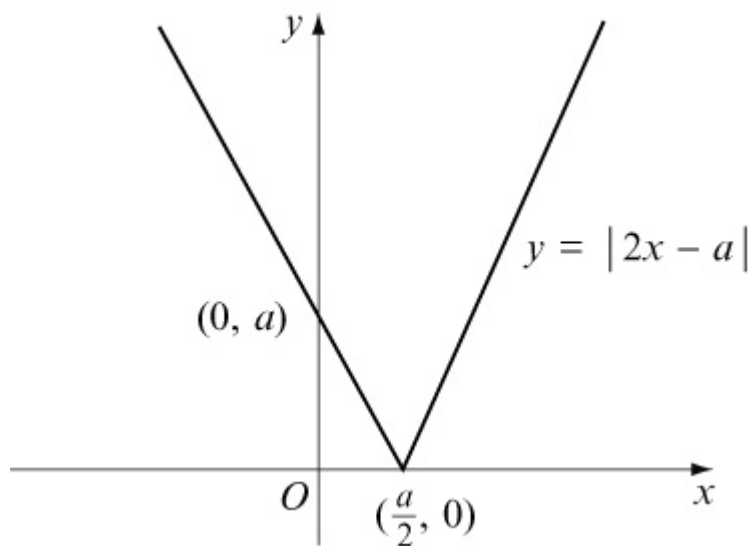

For  $y = |2x - a|$  :

When  $x = 0$ ,  $y = |-a| = a$   $(0, a)$

When  $y = 0$ ,  $2x - a = 0 \Rightarrow x = \frac{a}{2}$   $(\frac{a}{2}, 0)$

(b)  $y = f(2x)$  . Horizontal stretch, scale factor  $\frac{1}{2}$ .

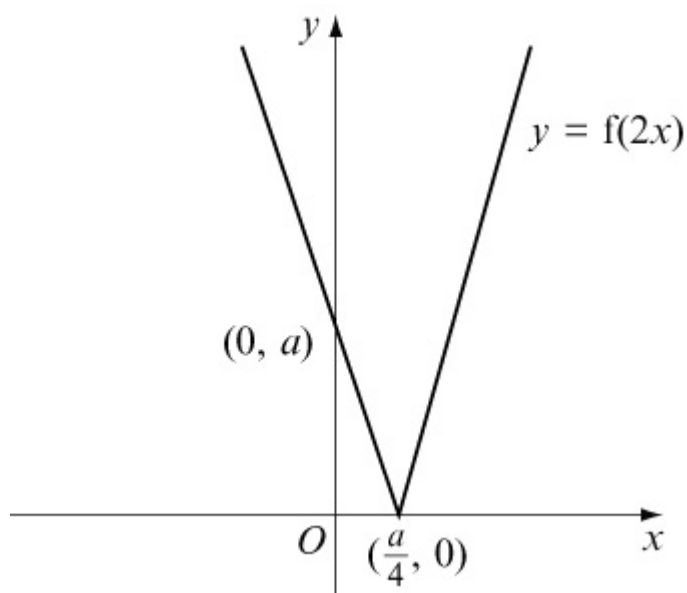

(c)  $f(x) = \frac{1}{2}x$  :  $|2x - a| = \frac{1}{2}x$

Either  $(2x - a) = \frac{1}{2}x$  or  $-(2x - a) = \frac{1}{2}x$

$2x - a = \frac{1}{2}x \Rightarrow a = \frac{3}{2}x$

Given that  $x = 4$ ,  $a = 6$

$$-(2x - a) = \frac{1}{2}x \Rightarrow -2x + a = \frac{1}{2}x \Rightarrow a = \frac{5}{2}x$$

Given that  $x = 4$ ,  $a = 10$

Either  $a = 6$  or  $a = 10$

© Pearson Education Ltd 2008



# Solutionbank

## Edexcel AS and A Level Modular Mathematics

### Exercise F, Question 6

#### Question:

(a) Sketch the graph of  $y = |x - 2a|$ , where  $a$  is a positive constant. Show the coordinates of the points where the graph meets the axes.

(b) Using algebra solve, for  $x$  in terms of  $a$ ,  $|x - 2a| = \frac{1}{3}x$ .

(c) On a separate diagram, sketch the graph of  $y = a - |x - 2a|$ , where  $a$  is a positive constant. Show the coordinates of the points where the graph cuts the axes.

[E]

#### Solution:

(a)

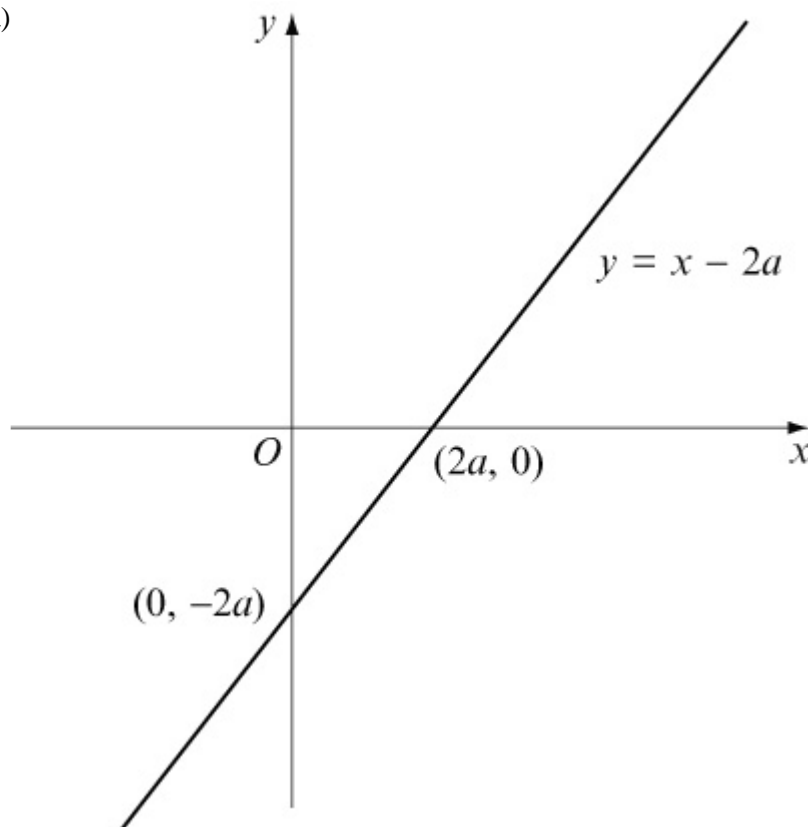

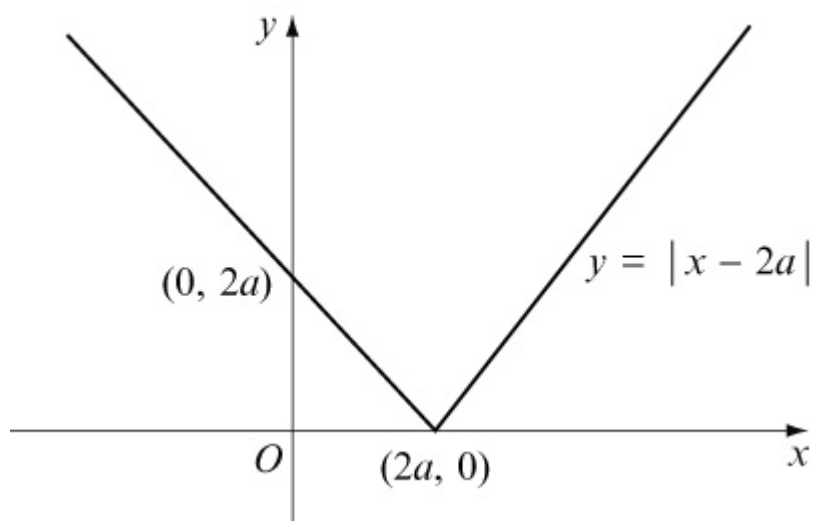

For  $y = |x - 2a|$  :

When  $x = 0$ ,  $y = |-2a| = 2a$   $(0, 2a)$

When  $y = 0$ ,  $x - 2a = 0 \Rightarrow x = 2a$   $(2a, 0)$

$$(b) \quad |x - 2a| = \frac{1}{3}x$$

Either  $(x - 2a) = \frac{1}{3}x$  or  $-(x - 2a) = \frac{1}{3}x$

$$x - 2a = \frac{1}{3}x \Rightarrow x - \frac{1}{3}x = 2a \Rightarrow \frac{2}{3}x = 2a \Rightarrow x = 3a$$

$$-x + 2a = \frac{1}{3}x \Rightarrow \frac{4}{3}x = 2a \Rightarrow x = \frac{3}{2}a$$

(c)  $y = -|x - 2a|$  . Reflection in  $x$ -axis of  $y = |x - 2a|$  .

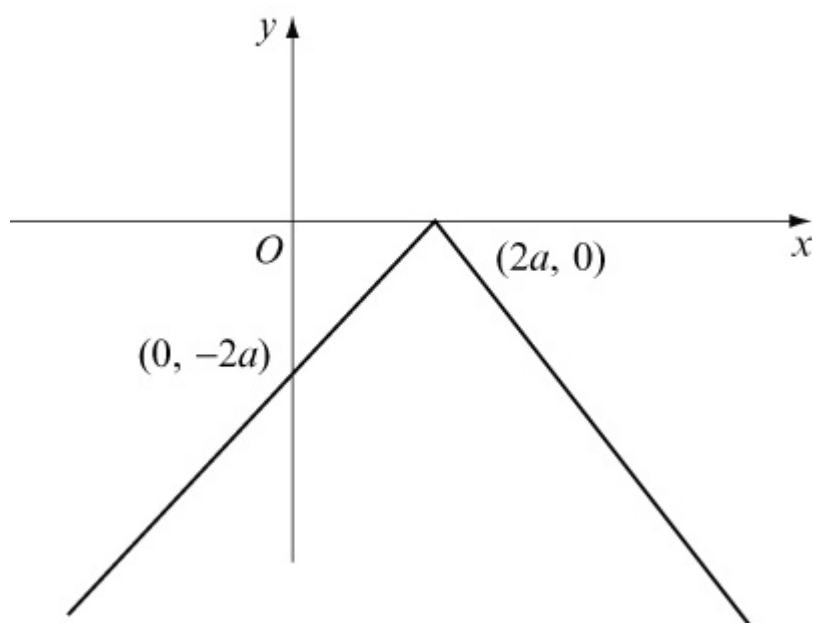

$y = a - |x - 2a|$ . Vertical translation of  $+a$ .

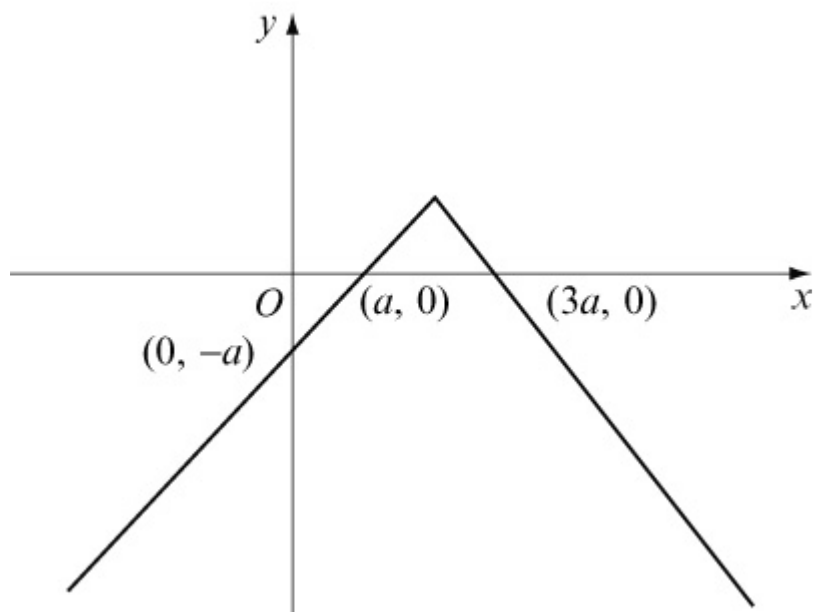

For  $y = a - |x - 2a|$  :

When  $x = 0$ ,  $y = a - |-2a| = a - 2a = -a$   $(0, -a)$

When  $y = 0$ ,  $a - |x - 2a| = 0$

$$|x - 2a| = a$$

Either  $x - 2a = a \Rightarrow x = 3a$   $(3a, 0)$

or  $-(x - 2a) = a \Rightarrow -x + 2a = a \Rightarrow x = a$   $(a, 0)$

# Solutionbank

## Edexcel AS and A Level Modular Mathematics

### Exercise F, Question 7

#### Question:

- (a) Sketch the graph of  $y = |2x + a|$ ,  $a > 0$ , showing the coordinates of the points where the graph meets the coordinate axes.
- (b) On the same axes, sketch the graph of  $y = \frac{1}{x}$ .
- (c) Explain how your graphs show that there is only one solution of the equation  $x |2x + a| - 1 = 0$ .
- (d) Find, using algebra, the value of  $x$  for which  $x |2x + a| - 1 = 0$ .

[E]

#### Solution:

(a)(b)

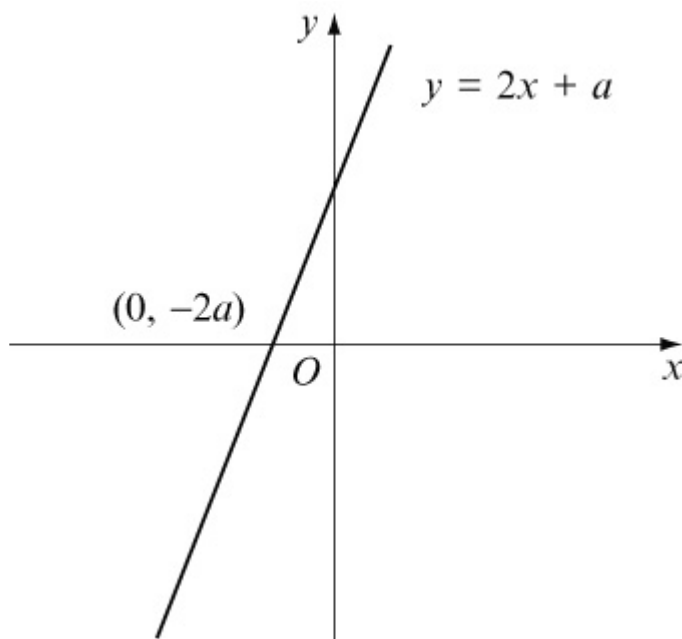

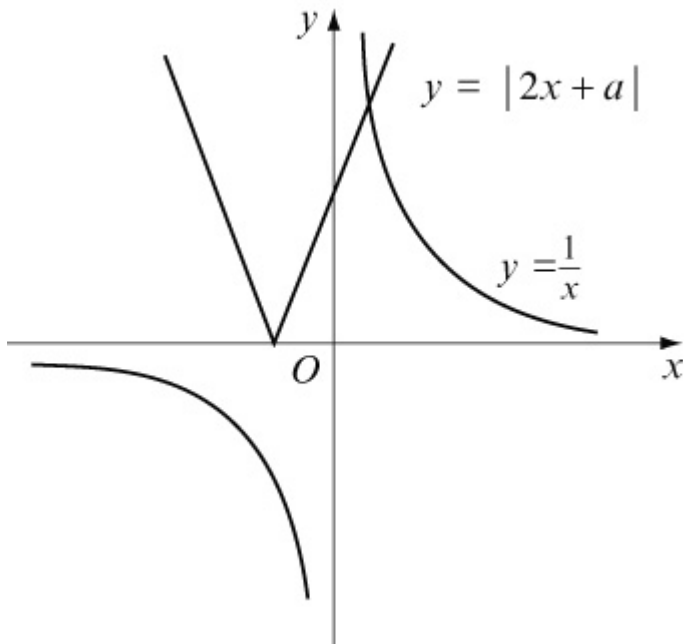

For  $y = |2x + a|$  :

When  $x = 0$ ,  $y = |a| = a \quad (0, a)$

When  $y = 0$ ,  $2x + a = 0 \Rightarrow x = -\frac{a}{2} \quad \left(-\frac{a}{2}, 0\right)$

(c) Intersection of graphs is given by

$$|2x + a| = \frac{1}{x}$$

$$x|2x + a| = 1$$

$$x|2x + a| - 1 = 0$$

There is only one intersection point, so only one solution.

(d) The intersection point is on the non-reflected part of the modulus graph, so use  $(2x + a)$  rather than  $-(2x + a)$ .

$$x(2x + a) - 1 = 0$$

$$2x^2 + ax - 1 = 0$$

$$x = \frac{-a \pm \sqrt{a^2 + 8}}{4}$$

As shown on the graph,  $x$  is positive, so

$$x = \frac{-a + \sqrt{a^2 + 8}}{4}$$

# Solutionbank

## Edexcel AS and A Level Modular Mathematics

### Exercise F, Question 8

#### Question:

The diagram shows part of the curve with equation  $y = f(x)$ , where

$$f(x) = x^2 - 7x + 5 \ln x + 8 \quad x > 0$$

The points A and B are the stationary points of the curve.

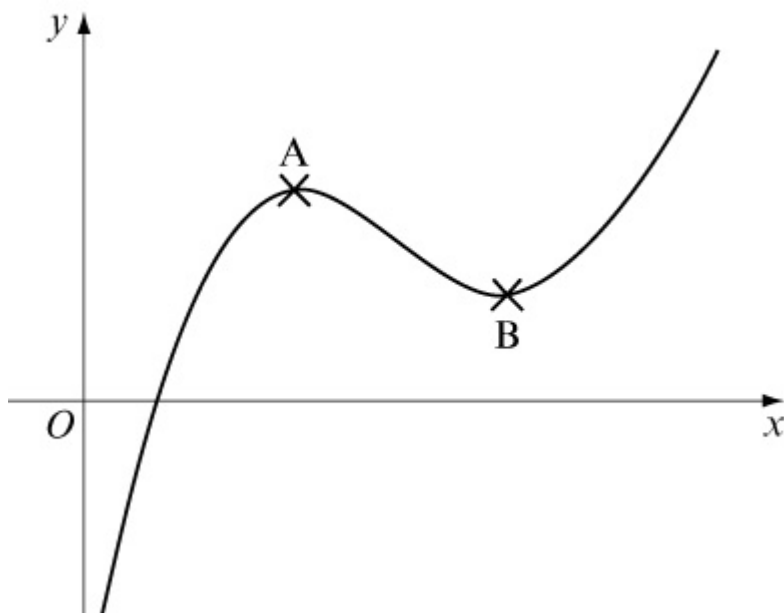

(a) Using calculus and showing your working, find the coordinates of the points A and B.

(b) Sketch the curve with equation  $y = -3f(x - 2)$ .

(c) Find the coordinates of the stationary points of the curve with equation  $y = -3f(x - 2)$ . State, without proof, which point is a maximum and which point is a minimum.

[E]

#### Solution:

$$(a) f(x) = x^2 - 7x + 5 \ln x + 8$$

$$f'(x) = 2x - 7 + \frac{5}{x}$$

At stationary points,  $f'(x) = 0$ :

$$2x - 7 + \frac{5}{x} = 0$$

$$2x^2 - 7x + 5 = 0$$

$$(2x - 5)(x - 1) = 0$$

$$x = \frac{5}{2}, x = 1$$

Point A:  $x = 1, f(x) = 1 - 7 + 5 \ln 1 + 8 = 2$

A is (1, 2)

Point B:  $x = \frac{5}{2}, f(x) = \frac{25}{4} - \frac{35}{2} + 5 \ln \frac{5}{2} + 8 = 5 \ln \frac{5}{2} - \frac{13}{4}$

B is  $\left( \frac{5}{2}, 5 \ln \frac{5}{2} - \frac{13}{4} \right)$

(b)  $y = f(x - 2)$ . Horizontal translation of +2.

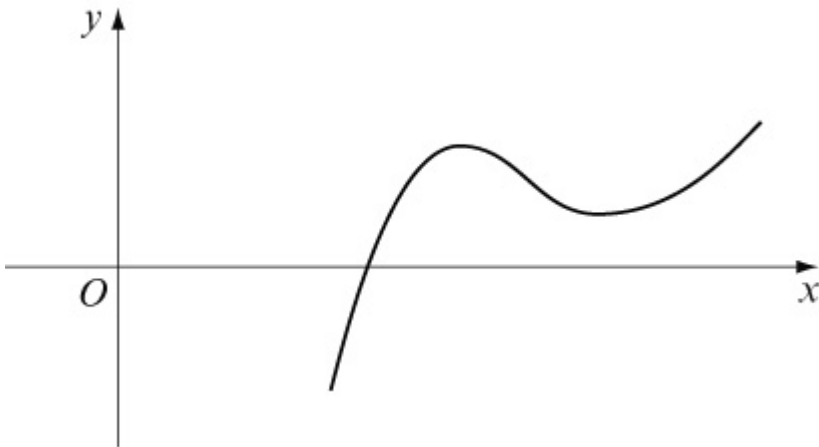

$y = -3f(x - 2)$ . Reflection in the  $x$ -axis, and vertical stretch, scale factor 3.

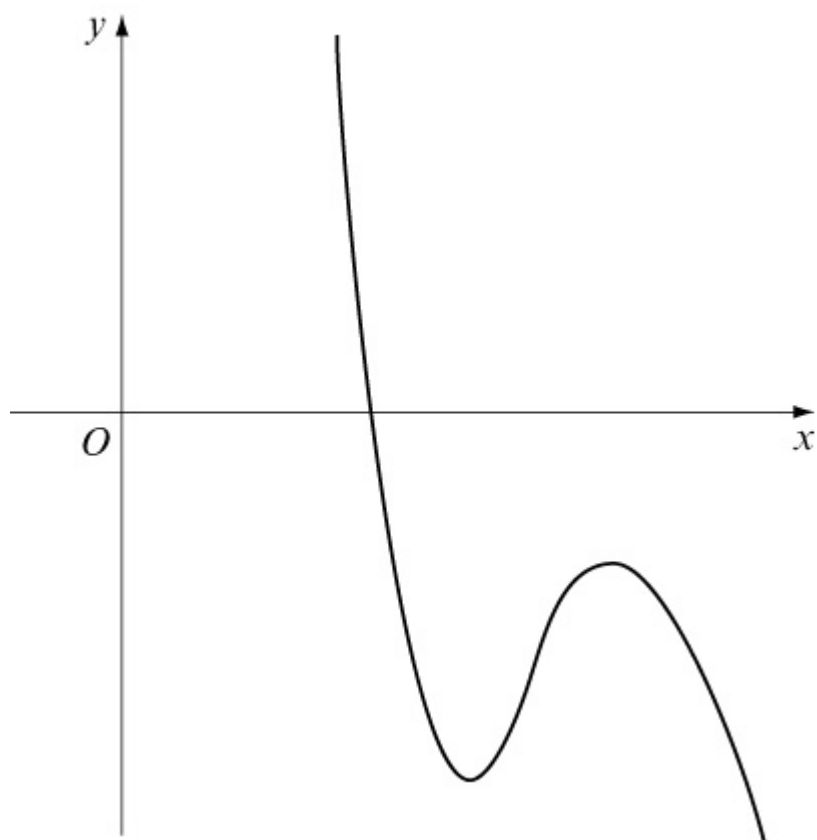

(c) Using the transformations, point  $(X, Y)$  becomes  $(X + 2, -3Y)$

$$(1, 2) \rightarrow (3, -6) \quad \text{Minimum}$$

$$\left( \frac{5}{2}, 5 \ln \frac{5}{2} - \frac{13}{4} \right) \rightarrow \left( \frac{9}{2}, \frac{39}{4} - 15 \ln \frac{5}{2} \right) \quad \text{Maximum}$$



# Solutionbank

## Edexcel AS and A Level Modular Mathematics

### Exercise A, Question 1

#### Question:

Without using your calculator, write down the sign of the following trigonometric ratios:

(a)  $\sec 300^\circ$

(b)  $\operatorname{cosec} 190^\circ$

(c)  $\cot 110^\circ$

(d)  $\cot 200^\circ$

(e)  $\sec 95^\circ$

#### Solution:

(a)  $300^\circ$  is in the 4th quadrant

$$\sec 300^\circ = \frac{1}{\cos 300^\circ}$$

In 4th quadrant  $\cos$  is +ve, so  $\sec 300^\circ$  is +ve.

(b)  $190^\circ$  is in the 3rd quadrant

$$\operatorname{cosec} 190^\circ = \frac{1}{\sin 190^\circ}$$

In 3rd quadrant  $\sin$  is -ve, so  $\operatorname{cosec} 190^\circ$  is -ve.

(c)  $110^\circ$  is in the 2nd quadrant

$$\cot 110^\circ = \frac{1}{\tan 110^\circ}$$

In the 2nd quadrant  $\tan$  is -ve, so  $\cot 110^\circ$  is -ve.

(d)  $200^\circ$  is in the 3rd quadrant.

$\tan$  is +ve in the 3rd quadrant, so  $\cot 200^\circ$  is +ve.

(e)  $95^\circ$  is in the 2nd quadrant

$\cos$  is -ve in the 2nd quadrant, so  $\sec 95^\circ$  is -ve.

# Solutionbank

## Edexcel AS and A Level Modular Mathematics

### Exercise A, Question 2

#### Question:

Use your calculator to find, to 3 significant figures, the values of

(a)  $\sec 100^\circ$

(b)  $\operatorname{cosec} 260^\circ$

(c)  $\operatorname{cosec} 280^\circ$

(d)  $\cot 550^\circ$

(e)  $\cot \frac{4\pi}{3}$

(f)  $\sec 2.4^c$

(g)  $\operatorname{cosec} \frac{11\pi}{10}$

(h)  $\sec 6^c$

#### Solution:

$$(a) \sec 100^\circ = \frac{1}{\cos 100^\circ} = -5.76$$

$$(b) \operatorname{cosec} 260^\circ = \frac{1}{\sin 260^\circ} = -1.02$$

$$(c) \operatorname{cosec} 280^\circ = \frac{1}{\sin 280^\circ} = -1.02$$

$$(d) \cot 550^\circ = \frac{1}{\tan 550^\circ} = 5.67$$

$$(e) \cot \frac{4\pi}{3} = \frac{1}{\tan \frac{4\pi}{3}} = 0.577$$

$$(f) \sec 2.4^{\circ} = \frac{1}{\cos 2.4^{\circ}} = -1.36$$

$$(g) \operatorname{cosec} \frac{11\pi}{10} = \frac{1}{\sin \frac{11\pi}{10}} = -3.24$$

$$(h) \sec 6^{\circ} = \frac{1}{\cos 6^{\circ}} = 1.04$$

© Pearson Education Ltd 2008

# Solutionbank

## Edexcel AS and A Level Modular Mathematics

### Exercise A, Question 3

#### Question:

Find the exact value (in surd form where appropriate) of the following:

(a)  $\operatorname{cosec} 90^\circ$

(b)  $\cot 135^\circ$

(c)  $\sec 180^\circ$

(d)  $\sec 240^\circ$

(e)  $\operatorname{cosec} 300^\circ$

(f)  $\cot (-45^\circ)$

(g)  $\sec 60^\circ$

(h)  $\operatorname{cosec} (-210^\circ)$

(i)  $\sec 225^\circ$

(j)  $\cot \frac{4\pi}{3}$

(k)  $\sec \frac{11\pi}{6}$

(l)  $\operatorname{cosec} \left( -\frac{3\pi}{4} \right)$

#### Solution:

(a)  $\operatorname{cosec} 90^\circ = \frac{1}{\sin 90^\circ} = \frac{1}{1} = 1$  (refer to graph of  $y = \sin \theta$ )

(b)  $\cot 135^\circ = \frac{1}{\tan 135^\circ} = \frac{1}{-\tan 45^\circ} = \frac{1}{-1} = -1$

(c)  $\sec 180^\circ = \frac{1}{\cos 180^\circ} = \frac{1}{-1} = -1$  (refer to graph of  $y = \cos \theta$ )

(d)  $240^\circ$  is in 3rd quadrant

$$\sec 240^\circ = \frac{1}{\cos 240^\circ} = \frac{1}{-\cos 60^\circ} = \frac{1}{-\frac{1}{2}} = -2$$

$$(e) \operatorname{cosec} 300^\circ = \frac{1}{\sin 300^\circ} = \frac{1}{-\sin 60^\circ} = -\frac{1}{\frac{1}{2}\sqrt{3}} = -\frac{2}{\sqrt{3}} = -\frac{2\sqrt{3}}{3}$$

$$(f) \cot(-45^\circ) = \frac{1}{\tan(-45^\circ)} = \frac{1}{-\tan 45^\circ} = \frac{1}{-1} = -1$$

$$(g) \sec 60^\circ = \frac{1}{\cos 60^\circ} = \frac{1}{\frac{1}{2}} = 2$$

(h)  $-210^\circ$  is in 2nd quadrant

$$\operatorname{cosec}(-210^\circ) = \frac{1}{\sin(-210^\circ)} = \frac{1}{\sin 30^\circ} = \frac{1}{\frac{1}{2}} = 2$$

(i)  $225^\circ$  is in 3rd quadrant

$$\begin{aligned} \sec 225^\circ &= \frac{1}{\cos 225^\circ} = \frac{1}{-\cos 45^\circ} \\ &= \frac{1}{-\frac{1}{\sqrt{2}}} = -\sqrt{2} \end{aligned}$$

(j)  $\frac{4\pi}{3}$  is in 3rd quadrant

$$\cot \frac{4\pi}{3} = \frac{1}{\tan \frac{4\pi}{3}} = \frac{1}{+\tan \frac{\pi}{3}} = \frac{1}{\sqrt{3}} = \frac{\sqrt{3}}{3}$$

(k)  $\frac{11\pi}{6} = 2\pi - \frac{\pi}{6}$  (in 4th quadrant)

$$\sec \frac{11\pi}{6} = \frac{1}{\cos \frac{11\pi}{6}} = \frac{1}{\cos \frac{\pi}{6}} = \frac{1}{\frac{\sqrt{3}}{2}} = \frac{2}{\sqrt{3}} = \frac{2\sqrt{3}}{3}$$

(1)

$$\operatorname{cosec} = \left(-\frac{3\pi}{4}\right) = \frac{1}{\sin\left(-\frac{3\pi}{4}\right)} = \frac{1}{-\sin\frac{\pi}{4}} = \frac{1}{-\frac{1}{\sqrt{2}}} = -\sqrt{2}$$

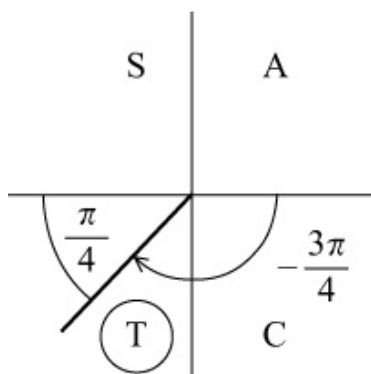

© Pearson Education Ltd 2008

# Solutionbank

## Edexcel AS and A Level Modular Mathematics

### Exercise A, Question 4

#### Question:

(a) Copy and complete the table, showing values (to 2 decimal places) of  $\sec \theta$  for selected values of  $\theta$ .

$\theta$	$0^\circ$	$30^\circ$	$45^\circ$	$60^\circ$	$70^\circ$	$80^\circ$	$85^\circ$	$95^\circ$
$\sec \theta$	1		1.41			5.76	11.47	

$\theta$	$100^\circ$	$110^\circ$	$120^\circ$	$135^\circ$	$150^\circ$	$180^\circ$	$210^\circ$
$\sec \theta$		-2.92		-1.41			-1.15

(b) Copy and complete the table, showing values (to 2 decimal places) of  $\operatorname{cosec} \theta$  for selected values of  $\theta$ .

$\theta$	$10^\circ$	$20^\circ$	$30^\circ$	$45^\circ$	$60^\circ$	$80^\circ$	$90^\circ$	$100^\circ$	$120^\circ$	$135^\circ$	$150^\circ$	$160^\circ$	$170^\circ$
$\operatorname{cosec} \theta$				1.41			1		1.15	1.41			

$\theta$	$190^\circ$	$200^\circ$	$210^\circ$	$225^\circ$	$240^\circ$	$270^\circ$	$300^\circ$	$315^\circ$	$330^\circ$	$340^\circ$	$350^\circ$	$390^\circ$
$\operatorname{cosec} \theta$					-1.15				-2			

(c) Copy and complete the table, showing values (to 2 decimal places) of  $\cot \theta$  for selected values of  $\theta$ .

$\theta$	$-90^\circ$	$-60^\circ$	$-45^\circ$	$-30^\circ$	$-10^\circ$	$10^\circ$	$30^\circ$	$45^\circ$	$60^\circ$
$\cot \theta$	0	-0.58					1.73	1	0.58

$\theta$	$90^\circ$	$120^\circ$	$135^\circ$	$150^\circ$	$170^\circ$	$210^\circ$	$225^\circ$	$240^\circ$	$270^\circ$
$\cot \theta$			-1					0.58	

#### Solution:

(a) Change  $\sec \theta$  into  $\frac{1}{\cos \theta}$  and use your calculator.

$\theta$	$0^\circ$	$30^\circ$	$45^\circ$	$60^\circ$	$70^\circ$	$80^\circ$	$85^\circ$	$95^\circ$
$\sec \theta$	1	1.15	1.41	2	2.92	5.76	11.47	-11.47

$\theta$	$100^\circ$	$110^\circ$	$120^\circ$	$135^\circ$	$150^\circ$	$180^\circ$	$210^\circ$
$\sec \theta$	-5.76	-2.92	-2	-1.41	-1.15	-1	-1.15

(b) Change cosec  $\theta$  to  $\frac{1}{\sin \theta}$  and use your calculator.

$\theta$	$10^\circ$	$20^\circ$	$30^\circ$	$45^\circ$	$60^\circ$	$80^\circ$	$90^\circ$	$100^\circ$	$120^\circ$
cosec $\theta$	5.76	2.92	2	1.41	1.15	1.02	1	1.02	1.15

$\theta$	$135^\circ$	$150^\circ$	$160^\circ$	$170^\circ$	$190^\circ$	$200^\circ$	$210^\circ$	$225^\circ$	$240^\circ$
cosec $\theta$	1.41	2	2.92	5.76	-5.76	-2.92	-2	-1.41	-1.15

$\theta$	$270^\circ$	$300^\circ$	$315^\circ$	$330^\circ$	$340^\circ$	$350^\circ$	$390^\circ$
cosec $\theta$	-1	-1.15	-1.41	-2	-2.92	-5.76	2

(c) Change cot  $\theta$  to  $\frac{1}{\tan \theta}$  and use your calculator.

$\theta$	$-90^\circ$	$-60^\circ$	$-45^\circ$	$-30^\circ$	$-10^\circ$	$10^\circ$	$30^\circ$	$45^\circ$	$60^\circ$
cot $\theta$	0	-0.58	-1	-1.73	-5.67	5.67	1.73	1	0.58

$\theta$	$90^\circ$	$120^\circ$	$135^\circ$	$150^\circ$	$170^\circ$	$210^\circ$	$225^\circ$	$240^\circ$	$270^\circ$
cot $\theta$	0	-0.58	-1	-1.73	-5.67	1.73	1	0.58	0



# Solutionbank

## Edexcel AS and A Level Modular Mathematics

### Exercise B, Question 1

#### Question:

(a) Sketch, in the interval  $-540^\circ \leq \theta \leq 540^\circ$ , the graphs of:

(i)  $\sec \theta$  (ii)  $\operatorname{cosec} \theta$  (iii)  $\cot \theta$

(b) Write down the range of

(i)  $\sec \theta$  (ii)  $\operatorname{cosec} \theta$  (iii)  $\cot \theta$

#### Solution:

(a)(i)

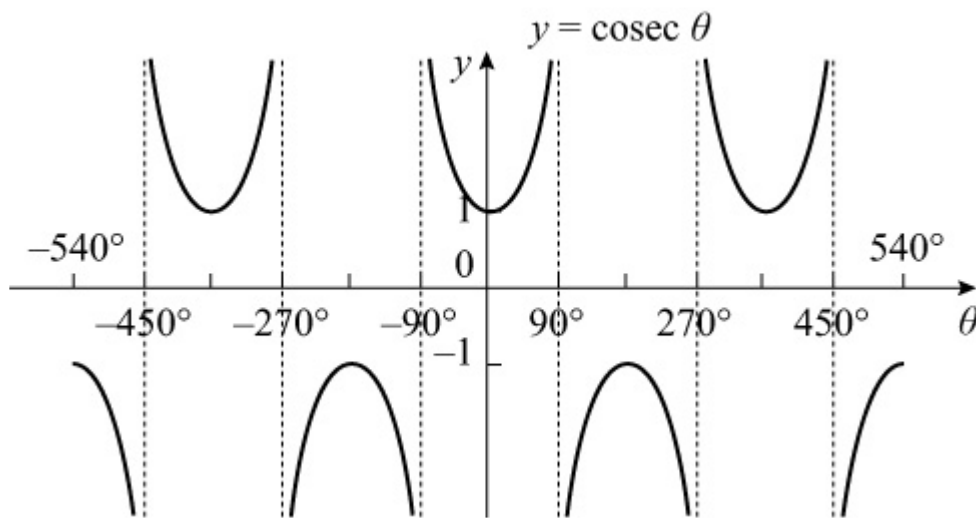

(ii)

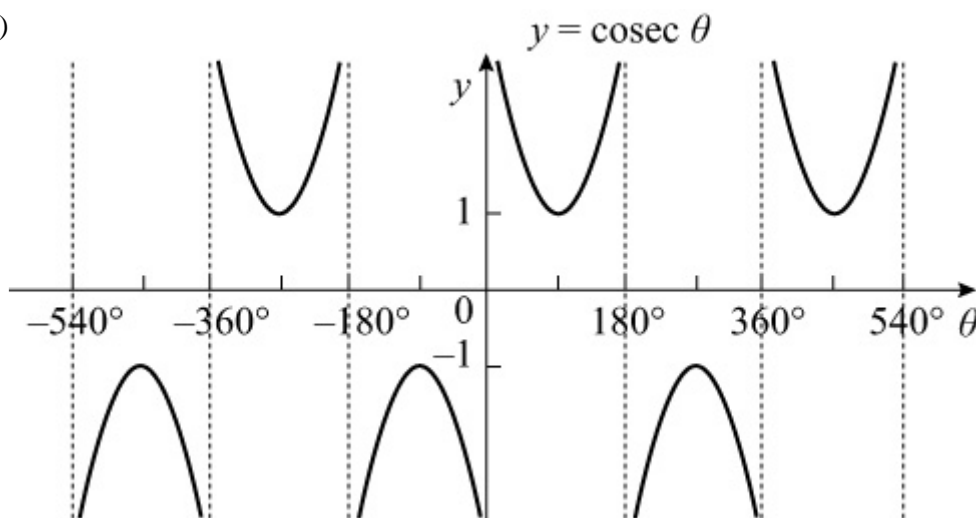

(iii)

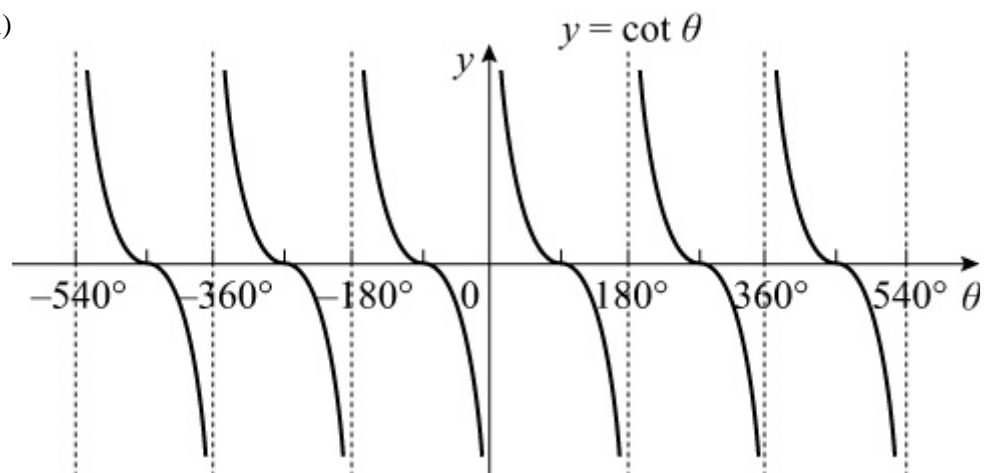

(b)(i) (Note the gap in the range)  $\sec \theta \leq -1$ ,  $\sec \theta \geq 1$

(ii) (cosec  $\theta$  also has a gap in the range)  $\text{cosec } \theta \leq -1$ ,  $\text{cosec } \theta \geq 1$

(iii)  $\cot \theta$  takes all real values, i.e.  $\cot \theta \in \mathbb{R}$ .

# Solutionbank

## Edexcel AS and A Level Modular Mathematics

### Exercise B, Question 2

#### Question:

- (a) Sketch, on the same set of axes, in the interval  $0 \leq \theta \leq 360^\circ$ , the graphs of  $y = \sec \theta$  and  $y = -\cos \theta$ .
- (b) Explain how your graphs show that  $\sec \theta = -\cos \theta$  has no solutions.

#### Solution:

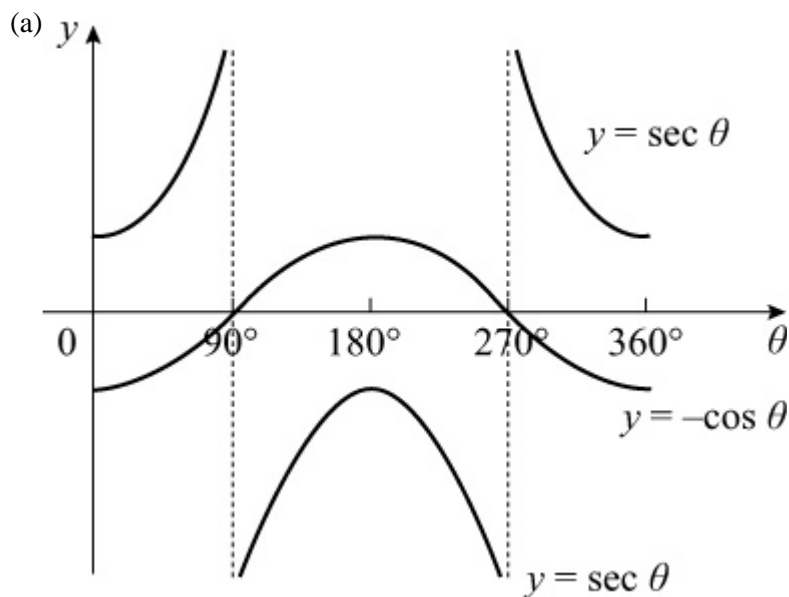

- (b) You can see that the graphs of  $\sec \theta$  and  $-\cos \theta$  do not meet, so  $\sec \theta = -\cos \theta$  has no solutions.

Algebraically, the solutions of  $\sec \theta = -\cos \theta$

are those of  $\frac{1}{\cos \theta} = -\cos \theta$

This requires  $\cos^2 \theta = -1$ , which is not possible for real  $\theta$ .

# Solutionbank

## Edexcel AS and A Level Modular Mathematics

### Exercise B, Question 3

#### Question:

- (a) Sketch, on the same set of axes, in the interval  $0 \leq \theta \leq 360^\circ$ , the graphs of  $y = \cot \theta$  and  $y = \sin 2\theta$ .
- (b) Deduce the number of solutions of the equation  $\cot \theta = \sin 2\theta$  in the interval  $0 \leq \theta \leq 360^\circ$ .

#### Solution:

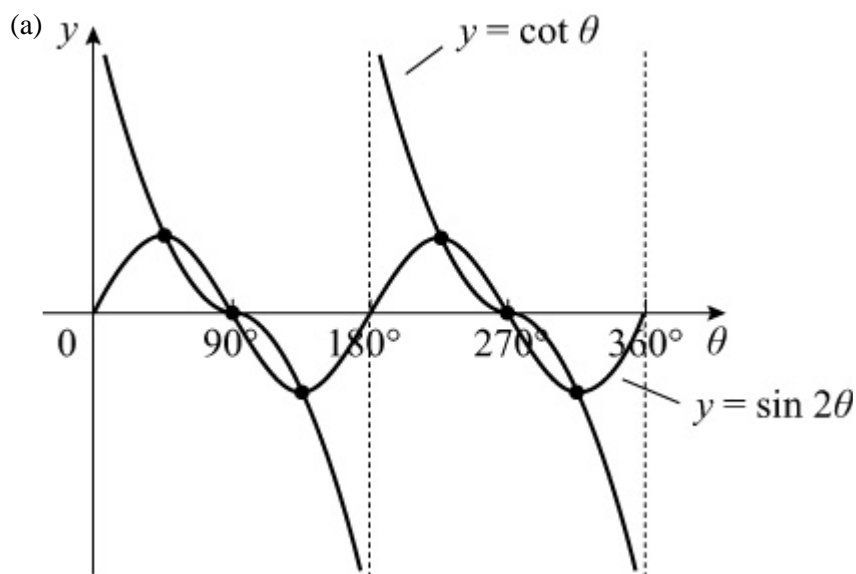

- (b) The curves meet at the maxima and minima of  $y = \sin 2\theta$ , and on the  $\theta$ -axis at odd integer multiples of  $90^\circ$ .  
 In the interval  $0 \leq \theta \leq 360^\circ$  there are 6 intersections.  
 So there are 6 solutions of  $\cot \theta = \sin 2\theta$ , is  $0 \leq \theta \leq 360^\circ$ .

# Solutionbank

## Edexcel AS and A Level Modular Mathematics

Exercise B, Question 4

### Question:

- (a) Sketch on separate axes, in the interval  $0 \leq \theta \leq 360^\circ$ , the graphs of  $y = \tan \theta$  and  $y = \cot(\theta + 90^\circ)$ .
- (b) Hence, state a relationship between  $\tan \theta$  and  $\cot(\theta + 90^\circ)$ .

### Solution:

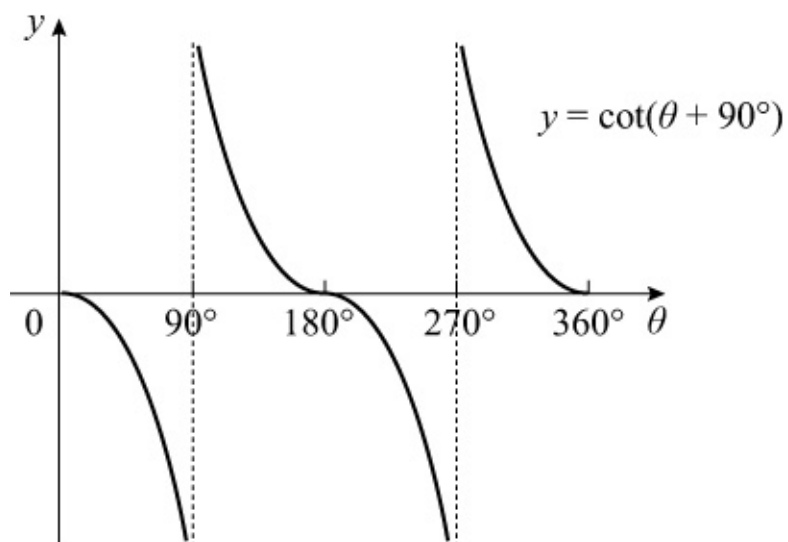
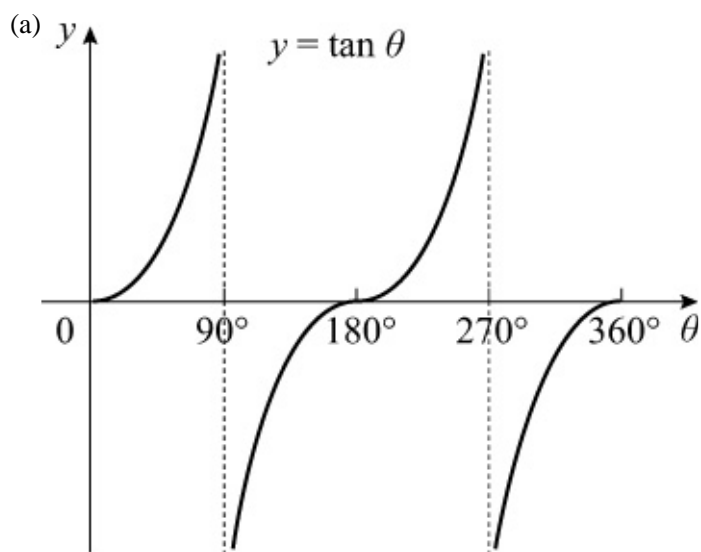

- (b)  $y = \cot(\theta + 90^\circ)$  is a reflection in the  $\theta$ -axis of  $y = \tan \theta$ , so  $\cot(\theta + 90^\circ) = -\tan \theta$

# Solutionbank

## Edexcel AS and A Level Modular Mathematics

### Exercise B, Question 5

#### Question:

(a) Describe the relationships between the graphs of

(i)  $\tan \left( \theta + \frac{\pi}{2} \right)$  and  $\tan \theta$

(ii)  $\cot ( - \theta )$  and  $\cot \theta$

(iii)  $\operatorname{cosec} \left( \theta + \frac{\pi}{4} \right)$  and  $\operatorname{cosec} \theta$

(iv)  $\sec \left( \theta - \frac{\pi}{4} \right)$  and  $\sec \theta$

(b) By considering the graphs of  $\tan \left( \theta + \frac{\pi}{2} \right)$ ,  $\cot ( - \theta )$ ,  $\operatorname{cosec} \left( \theta + \frac{\pi}{4} \right)$  and  $\sec \left( \theta - \frac{\pi}{4} \right)$ , state which pairs of functions are equal.

#### Solution:

(a) (i) The graph of  $\tan \left( \theta + \frac{\pi}{2} \right)$  is the same as that of  $\tan \theta$  translated by  $\frac{\pi}{2}$  to the left.

(ii) The graph of  $\cot ( - \theta )$  is the same as that of  $\cot \theta$  reflected in the y-axis.

(iii) The graph of  $\operatorname{cosec} \left( \theta + \frac{\pi}{4} \right)$  is the same as that of  $\operatorname{cosec} \theta$  translated by  $\frac{\pi}{4}$  to the left.

(iv) The graph of  $\sec \left( \theta - \frac{\pi}{4} \right)$  is the same as that of  $\sec \theta$  translated by  $\frac{\pi}{4}$  to the right.

(b)

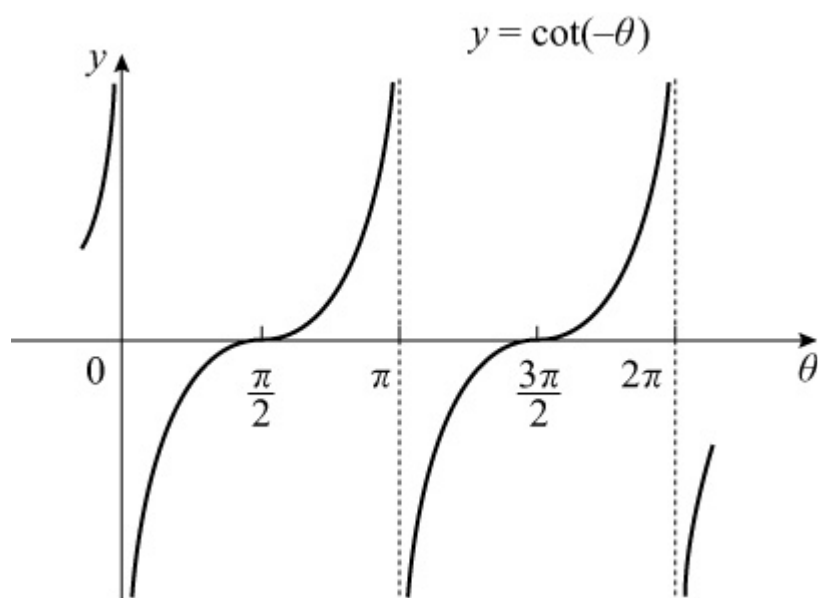
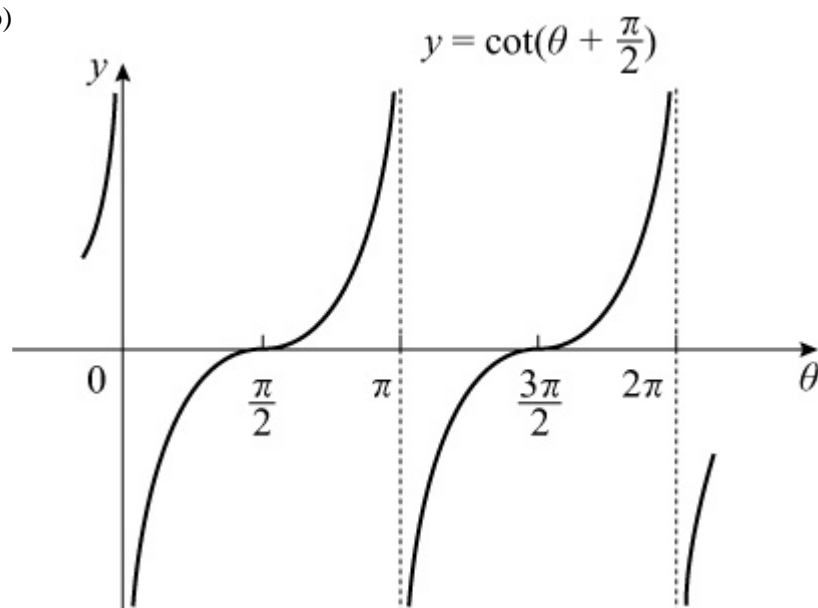
(reflect  $y = \cot \theta$  in the  $y$ -axis)

$$\tan\left(\theta + \frac{\pi}{2}\right) = \cot(-\theta)$$

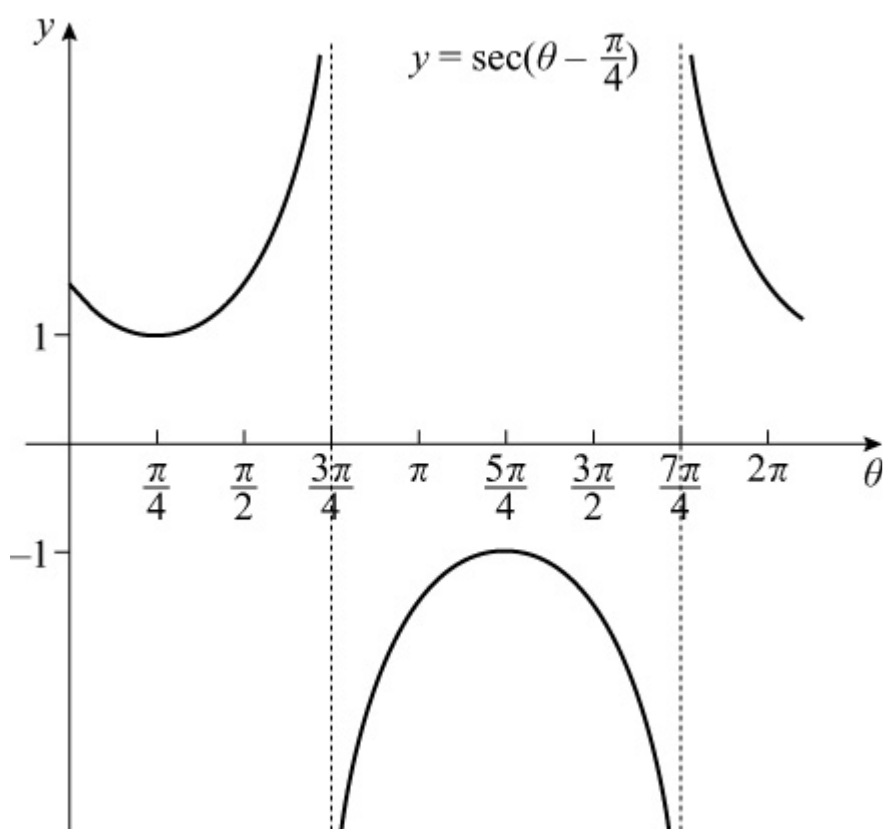
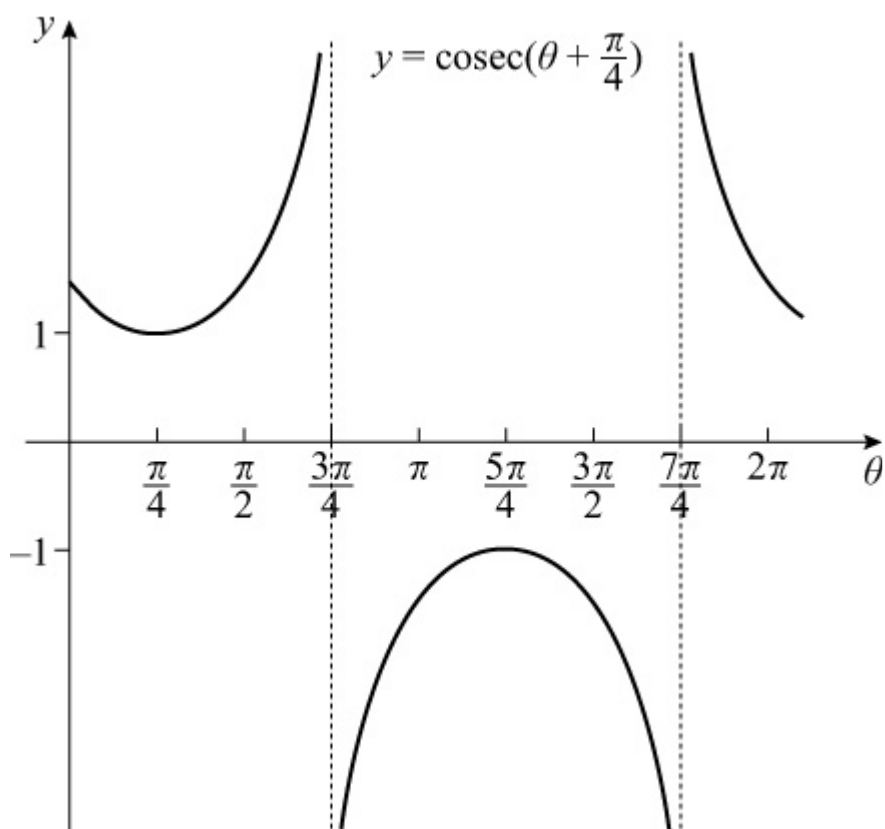

$$\operatorname{cosec}\left(\theta + \frac{\pi}{4}\right) = \sec\left(\theta - \frac{\pi}{4}\right)$$





# Solutionbank

## Edexcel AS and A Level Modular Mathematics

### Exercise B, Question 6

#### Question:

Sketch on separate axes, in the interval  $0 \leq \theta \leq 360^\circ$ , the graphs of:

(a)  $y = \sec 2\theta$

(b)  $y = -\operatorname{cosec} \theta$

(c)  $y = 1 + \sec \theta$

(d)  $y = \operatorname{cosec} (\theta - 30^\circ)$

In each case show the coordinates of any maximum and minimum points, and of any points at which the curve meets the axes.

#### Solution:

(a) A stretch of  $y = \sec \theta$  in the  $\theta$  direction with scale factor  $\frac{1}{2}$ .

Minimum at  $(180^\circ, 1)$

Maxima at  $(90^\circ, -1)$  and  $(270^\circ, -1)$

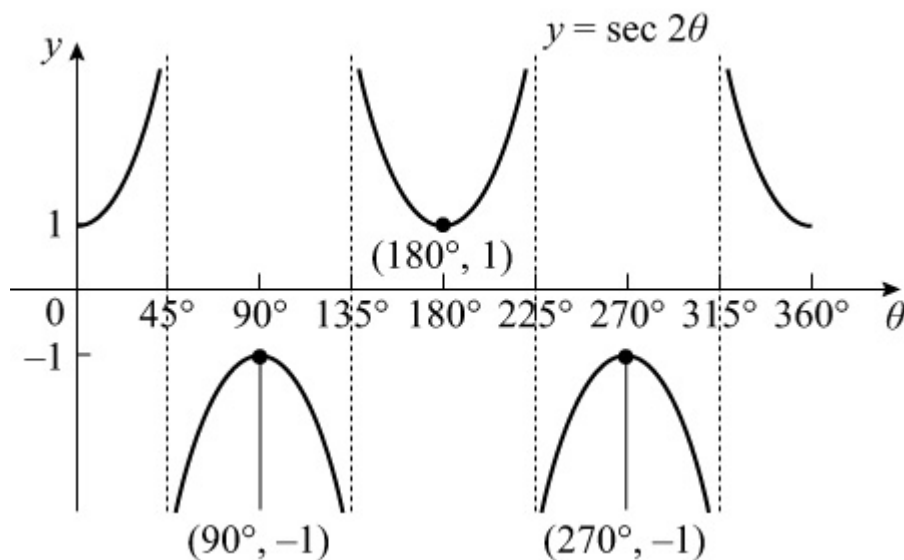

(b) Reflection in  $\theta$ -axis of  $y = \operatorname{cosec} \theta$ .

Minimum at  $(270^\circ, 1)$

Maximum at  $(90^\circ, -1)$

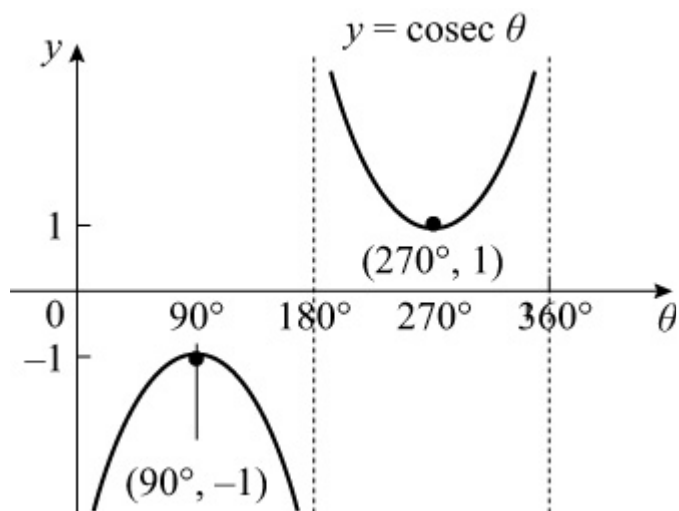

(c) Translation of  $y = \sec \theta$  by  $+1$  in the  $y$  direction.  
Maximum at  $(180^\circ, 0)$

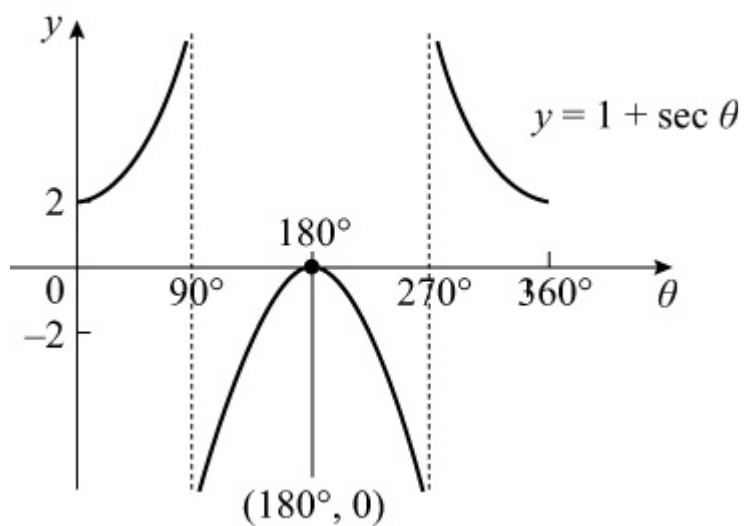

(d) Translation of  $y = \operatorname{cosec} \theta$  by  $30^\circ$  to the right.  
Minimum at  $(120^\circ, 1)$   
Maximum at  $(300^\circ, -1)$

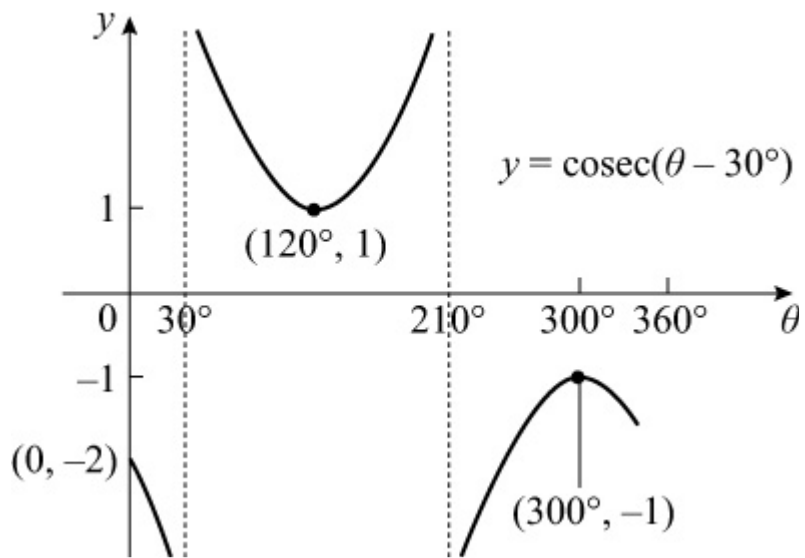

© Pearson Education Ltd 2008

# Solutionbank

## Edexcel AS and A Level Modular Mathematics

### Exercise B, Question 7

#### Question:

Write down the periods of the following functions. Give your answer in terms of  $\pi$ .

(a)  $\sec 3\theta$

(b)  $\operatorname{cosec} \frac{1}{2}\theta$

(c)  $2 \cot \theta$

(d)  $\sec (-\theta)$

#### Solution:

(a) The period of  $\sec \theta$  is  $2\pi$  radians.

$y = \sec 3\theta$  is a stretch of  $y = \sec \theta$  with scale factor  $\frac{1}{3}$  in the  $\theta$  direction.

So period of  $\sec 3\theta$  is  $\frac{2\pi}{3}$ .

(b)  $\operatorname{cosec} \theta$  has a period of  $2\pi$ .

$\operatorname{cosec} \frac{1}{2}\theta$  is a stretch of  $\operatorname{cosec} \theta$  in the  $\theta$  direction with scale factor 2.

So period of  $\operatorname{cosec} \frac{1}{2}\theta$  is  $4\pi$ .

(c)  $\cot \theta$  has a period of  $\pi$ .

$2 \cot \theta$  is a stretch in the  $y$  direction by scale factor 2.

So the periodicity is not affected.

Period of  $2 \cot \theta$  is  $\pi$ .

(d)  $\sec \theta$  has a period of  $2\pi$ .

$\sec (-\theta)$  is a reflection of  $\sec \theta$  in  $y$ -axis, so periodicity is unchanged.

Period of  $\sec (-\theta)$  is  $2\pi$ .

# Solutionbank

## Edexcel AS and A Level Modular Mathematics

### Exercise B, Question 8

#### Question:

- (a) Sketch the graph of  $y = 1 + 2 \sec \theta$  in the interval  $-\pi \leq \theta \leq 2\pi$ .
- (b) Write down the y-coordinate of points at which the gradient is zero.
- (c) Deduce the maximum and minimum values of  $\frac{1}{1 + 2 \sec \theta}$ , and give the smallest positive values of  $\theta$  at which they occur.

#### Solution:

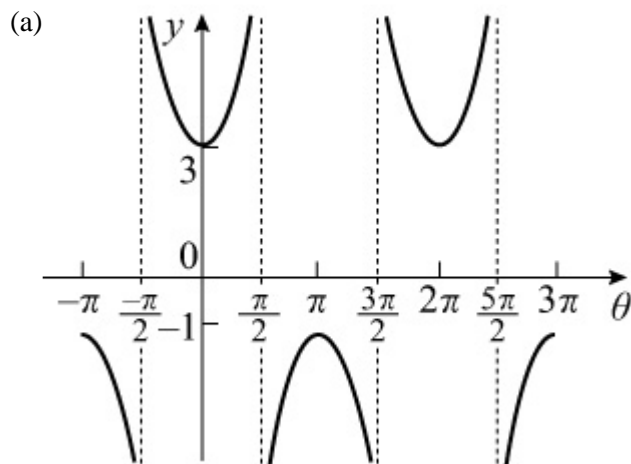

- (b) The y coordinates at stationary points are  $-1$  and  $3$ .

- (c) Minimum value of  $\frac{1}{1 + 2 \sec \theta}$  is where  $1 + 2 \sec \theta$  is a maximum.

So minimum value of  $\frac{1}{1 + 2 \sec \theta}$  is  $\frac{1}{-1} = -1$

It occurs when  $\theta = \pi$  (see diagram) (1st +ve value)

Maximum value of  $\frac{1}{1 + 2 \sec \theta}$  is where  $1 + 2 \sec \theta$  is a minimum.

So maximum value of  $\frac{1}{1 + 2 \sec \theta}$  is  $\frac{1}{3}$

It occurs when  $\theta = 2\pi$  (1st +ve value)

# Solutionbank

## Edexcel AS and A Level Modular Mathematics

### Exercise C, Question 1

#### Question:

Give solutions to these equations correct to 1 decimal place.

Rewrite the following as powers of  $\sec \theta$ ,  $\operatorname{cosec} \theta$  or  $\cot \theta$ :

(a)  $\frac{1}{\sin^3 \theta}$

(b)  $\sqrt{\frac{4}{\tan^6 \theta}}$

(c)  $\frac{1}{2 \cos^2 \theta}$

(d)  $\frac{1 - \sin^2 \theta}{\sin^2 \theta}$

(e)  $\frac{\sec \theta}{\cos^4 \theta}$

(f)  $\sqrt{\operatorname{cosec}^3 \theta \cot \theta \sec \theta}$

(g)  $\sqrt{\tan \theta}$

(h)  $\frac{\operatorname{cosec}^2 \theta \tan^2 \theta}{\cos \theta}$

#### Solution:

(a)  $\frac{1}{\sin^3 \theta} = \left( \frac{1}{\sin \theta} \right)^3 = \operatorname{cosec}^3 \theta$

(b)  $\sqrt{\frac{4}{\tan^6 \theta}} = \frac{2}{\tan^3 \theta} = 2 \times \left( \frac{1}{\tan \theta} \right)^3 = 2 \cot^3 \theta$

$$(c) \frac{1}{2 \cos^2 \theta} = \frac{1}{2} \times \left( \frac{1}{\cos \theta} \right)^2 = \frac{1}{2} \sec^2 \theta$$

$$(d) \frac{1 - \sin^2 \theta}{\sin^2 \theta} = \frac{\cos^2 \theta}{\sin^2 \theta} \quad (\text{using } \sin^2 \theta + \cos^2 \theta \equiv 1)$$

$$\text{So } \frac{1 - \sin^2 \theta}{\sin^2 \theta} = \left( \frac{\cos \theta}{\sin \theta} \right)^2 = \cot^2 \theta$$

$$(e) \frac{\sec \theta}{\cos^4 \theta} = \frac{1}{\cos \theta} \times \frac{1}{\cos^4 \theta} = \frac{1}{\cos^5 \theta} = \left( \frac{1}{\cos \theta} \right)^5 = \sec^5 \theta$$

$$(f) \sqrt{\operatorname{cosec}^3 \theta \cot \theta \sec \theta} = \sqrt{\frac{1}{\sin^3 \theta} \times \frac{\cos \theta}{\sin \theta} \times \frac{1}{\cos \theta}} = \sqrt{\frac{1}{\sin^4 \theta}} =$$

$$\frac{1}{\sin^2 \theta} = \operatorname{cosec}^2 \theta$$

$$(g) \sqrt{\frac{2}{\tan \theta}} = 2 \times \frac{1}{(\tan \theta)^{\frac{1}{2}}} = 2 \cot^{\frac{1}{2}} \theta$$

$$(h) \frac{\operatorname{cosec}^2 \theta \tan^2 \theta}{\cos \theta} = \frac{1}{\sin^2 \theta} \times \frac{\sin^2 \theta}{\cos^2 \theta} \times \frac{1}{\cos \theta} = \left( \frac{1}{\cos \theta} \right)^3 = \sec^3 \theta$$



# Solutionbank

## Edexcel AS and A Level Modular Mathematics

### Exercise C, Question 2

#### Question:

Give solutions to these equations correct to 1 decimal place.

Write down the value(s) of  $\cot x$  in each of the following equations:

(a)  $5 \sin x = 4 \cos x$

(b)  $\tan x = -2$

(c)  $3 \frac{\sin x}{\cos x} = \frac{\cos x}{\sin x}$

#### Solution:

(a)  $5 \sin x = 4 \cos x$

$$\Rightarrow 5 = 4 \frac{\cos x}{\sin x} \quad (\text{divide by } \sin x)$$

$$\Rightarrow \frac{5}{4} = \cot x \quad (\text{divide by } 4)$$

(b)  $\tan x = -2$

$$\Rightarrow \frac{1}{\tan x} = \frac{1}{-2}$$

$$\Rightarrow \cot x = -\frac{1}{2}$$

(c)  $3 \frac{\sin x}{\cos x} = \frac{\cos x}{\sin x}$

$$\Rightarrow 3 \sin^2 x = \cos^2 x \quad (\text{multiply by } \sin x \cos x)$$

$$\Rightarrow 3 = \frac{\cos^2 x}{\sin^2 x} \quad (\text{divide by } \sin^2 x)$$

$$\Rightarrow \left( \frac{\cos x}{\sin x} \right)^2 = 3$$

$$\Rightarrow \cot^2 x = 3$$

$$\Rightarrow \cot x = \pm \sqrt{3}$$

# Solutionbank

## Edexcel AS and A Level Modular Mathematics

### Exercise C, Question 3

#### Question:

Give solutions to these equations correct to 1 decimal place.

Using the definitions of **sec**, **cosec**, **cot** and **tan** simplify the following expressions:

(a)  $\sin \theta \cot \theta$

(b)  $\tan \theta \cot \theta$

(c)  $\tan 2\theta \operatorname{cosec} 2\theta$

(d)  $\cos \theta \sin \theta (\cot \theta + \tan \theta)$

(e)  $\sin^3 x \operatorname{cosec} x + \cos^3 x \sec x$

(f)  $\sec A - \sec A \sin^2 A$

(g)  $\sec^2 x \cos^5 x + \cot x \operatorname{cosec} x \sin^4 x$

#### Solution:

(a)  $\sin \theta \cot \theta = \sin \theta \times \frac{\cos \theta}{\sin \theta} = \cos \theta$

(b)  $\tan \theta \cot \theta = \tan \theta \times \frac{1}{\tan \theta} = 1$

(c)  $\tan 2\theta \operatorname{cosec} 2\theta = \frac{\sin 2\theta}{\cos 2\theta} \times \frac{1}{\sin 2\theta} = \frac{1}{\cos 2\theta} = \sec 2\theta$

(d)  $\cos \theta \sin \theta (\cot \theta + \tan \theta) = \cos \theta \sin \theta \left( \frac{\cos \theta}{\sin \theta} + \frac{\sin \theta}{\cos \theta} \right)$   
 $= \cos^2 \theta + \sin^2 \theta = 1$

(e)  $\sin^3 x \operatorname{cosec} x + \cos^3 x \sec x = \sin^3 x \times \frac{1}{\sin x} + \cos^3 x \times$   
 $\frac{1}{\cos x} = \sin^2 x + \cos^2 x = 1$

$$\begin{aligned} \text{(f) } & \sec A - \sec A \sin^2 A \\ &= \sec A (1 - \sin^2 A) \quad (\text{factorise}) \\ &= \frac{1}{\cos A} \times \cos^2 A \quad (\text{using } \sin^2 A + \cos^2 A \equiv 1) \\ &= \cos A \end{aligned}$$

$$\begin{aligned} \text{(g) } & \sec^2 x \cos^5 x + \cot x \operatorname{cosec} x \sin^4 x \\ &= \frac{1}{\cos^2 x} \times \cos^5 x + \frac{\cos x}{\sin x} \times \frac{1}{\sin x} \times \sin^4 x \\ &= \cos^3 x + \sin^2 x \cos x \\ &= \cos x (\cos^2 x + \sin^2 x) \\ &= \cos x \quad (\text{since } \cos^2 x + \sin^2 x \equiv 1) \end{aligned}$$

# Solutionbank

## Edexcel AS and A Level Modular Mathematics

### Exercise C, Question 4

#### Question:

Show that

$$(a) \cos \theta + \sin \theta \tan \theta \equiv \sec \theta$$

$$(b) \cot \theta + \tan \theta \equiv \operatorname{cosec} \theta \sec \theta$$

$$(c) \operatorname{cosec} \theta - \sin \theta \equiv \cos \theta \cot \theta$$

$$(d) (1 - \cos x)(1 + \sec x) \equiv \sin x \tan x$$

$$(e) \frac{\cos x}{1 - \sin x} + \frac{1 - \sin x}{\cos x} \equiv 2 \sec x$$

$$(f) \frac{\cos \theta}{1 + \cot \theta} \equiv \frac{\sin \theta}{1 + \tan \theta}$$

#### Solution:

$$\begin{aligned} (a) \text{ L.H.S.} &\equiv \cos \theta + \sin \theta \tan \theta \\ &\equiv \cos \theta + \sin \theta \frac{\sin \theta}{\cos \theta} \\ &\equiv \frac{\cos^2 \theta + \sin^2 \theta}{\cos \theta} \\ &\equiv \frac{1}{\cos \theta} \quad (\text{using } \sin^2 \theta + \cos^2 \theta \equiv 1) \\ &\equiv \sec \theta \equiv \text{R.H.S.} \end{aligned}$$

$$\begin{aligned} (b) \text{ L.H.S.} &\equiv \cot \theta + \tan \theta \\ &\equiv \frac{\cos \theta}{\sin \theta} + \frac{\sin \theta}{\cos \theta} \\ &\equiv \frac{\cos^2 \theta + \sin^2 \theta}{\sin \theta \cos \theta} \\ &\equiv \frac{1}{\sin \theta \cos \theta} \\ &\equiv \frac{1}{\sin \theta} \times \frac{1}{\cos \theta} \\ &\equiv \operatorname{cosec} \theta \sec \theta \equiv \text{R.H.S.} \end{aligned}$$

$$\begin{aligned} (c) \text{ L.H.S.} &\equiv \operatorname{cosec} \theta - \sin \theta \\ &\equiv \frac{1}{\sin \theta} - \sin \theta \end{aligned}$$

$$\begin{aligned}
&\equiv \frac{1 - \sin^2 \theta}{\sin \theta} \\
&\equiv \frac{\cos^2 \theta}{\sin \theta} \\
&\equiv \cos \theta \times \frac{\cos \theta}{\sin \theta} \\
&\equiv \cos \theta \cot \theta \equiv \text{R.H.S.}
\end{aligned}$$

(d) L.H.S.  $\equiv (1 - \cos x)(1 + \sec x)$

$$\begin{aligned}
&\equiv 1 - \cos x + \sec x - \cos x \sec x \quad (\text{multiplying out}) \\
&\equiv \sec x - \cos x \\
&\equiv \frac{1}{\cos x} - \cos x \\
&\equiv \frac{1 - \cos^2 x}{\cos x} \\
&\equiv \frac{\sin^2 x}{\cos x} \\
&\equiv \sin x \times \frac{\sin x}{\cos x} \\
&\equiv \sin x \tan x \equiv \text{R.H.S.}
\end{aligned}$$

(e) L.H.S.  $\equiv \frac{\cos x}{1 - \sin x} + \frac{1 - \sin x}{\cos x}$

$$\begin{aligned}
&\equiv \frac{\cos^2 x + (1 - \sin x)^2}{(1 - \sin x) \cos x} \\
&\equiv \frac{\cos^2 x + (1 - 2 \sin x + \sin^2 x)}{(1 - \sin x) \cos x} \\
&\equiv \frac{2 - 2 \sin x}{(1 - \sin x) \cos x} \quad (\text{using } \sin^2 x + \cos^2 x \equiv 1) \\
&\equiv \frac{2(1 - \sin x)}{(1 - \sin x) \cos x} \quad (\text{factorising}) \\
&= \frac{2}{\cos x} \\
&\equiv 2 \sec x \equiv \text{R.H.S.}
\end{aligned}$$

(f)

$$\begin{aligned}\text{L.H.S.} &\equiv \frac{\cos \theta}{1 + \cot \theta} \\ &\equiv \frac{\cos \theta}{1 + \frac{1}{\tan \theta}} \\ &\equiv \frac{\cos \theta}{\frac{\tan \theta + 1}{\tan \theta}} \\ &\equiv \frac{\cos \theta \tan \theta}{1 + \tan \theta} \\ &\equiv \frac{\cos \theta \times \frac{\sin \theta}{\cos \theta}}{1 + \tan \theta} \\ &\equiv \frac{\sin \theta}{1 + \tan \theta} \equiv \text{R.H.S.}\end{aligned}$$

# Solutionbank

## Edexcel AS and A Level Modular Mathematics

### Exercise C, Question 5

#### Question:

Solve, for values of  $\theta$  in the interval  $0 \leq \theta \leq 360^\circ$ , the following equations. Give your answers to 3 significant figures where necessary.

(a)  $\sec \theta = \sqrt{2}$

(b)  $\operatorname{cosec} \theta = -3$

(c)  $5 \cot \theta = -2$

(d)  $\operatorname{cosec} \theta = 2$

(e)  $3 \sec^2 \theta - 4 = 0$

(f)  $5 \cos \theta = 3 \cot \theta$

(g)  $\cot^2 \theta - 8 \tan \theta = 0$

(h)  $2 \sin \theta = \operatorname{cosec} \theta$

#### Solution:

(a)  $\sec \theta = \sqrt{2}$

$$\Rightarrow \frac{1}{\cos \theta} = \sqrt{2}$$

$$\Rightarrow \cos \theta = \frac{1}{\sqrt{2}}$$

Calculator value is  $\theta = 45^\circ$

$\cos \theta$  is +ve  $\Rightarrow \theta$  in 1st and 4th quadrants

Solutions are  $45^\circ, 315^\circ$

(b)  $\operatorname{cosec} \theta = -3$

$$\Rightarrow \frac{1}{\sin \theta} = -3$$

$$\Rightarrow \sin \theta = -\frac{1}{3}$$

Calculator value is  $-19.5^\circ$

$\sin \theta$  is -ve  $\Rightarrow \theta$  is in 3rd and 4th quadrants

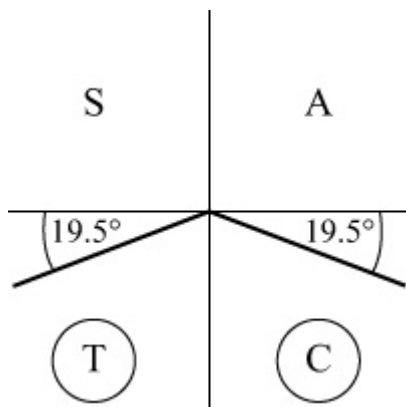

Solutions are  $199^\circ$ ,  $341^\circ$  (3 s.f.)

(c)  $5 \cot \theta = -2$

$$\Rightarrow \cot \theta = -\frac{2}{5}$$

$$\Rightarrow \tan \theta = -\frac{5}{2}$$

Calculator value is  $-68.2^\circ$

$\tan \theta$  is  $-ve \Rightarrow \theta$  is in 2nd and 4th quadrants

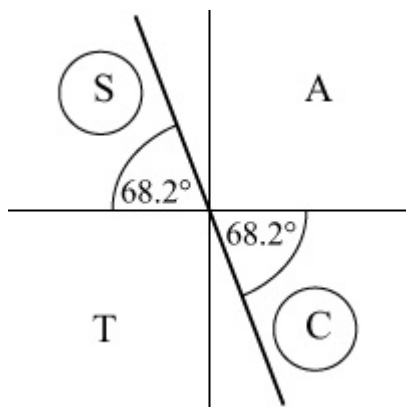

Solutions are  $112^\circ$ ,  $292^\circ$  (3 s.f.)

(d)  $\operatorname{cosec} \theta = 2$

$$\Rightarrow \frac{1}{\sin \theta} = 2$$

$$\Rightarrow \sin \theta = \frac{1}{2}$$

$\sin \theta$  is  $+ve \Rightarrow \theta$  is in 1st and 2nd quadrants

Solutions are  $30^\circ$ ,  $150^\circ$

(e)  $3 \sec^2 \theta = 4$



$$\Rightarrow \sec^2 \theta = \frac{4}{3}$$

$$\Rightarrow \cos^2 \theta = \frac{3}{4}$$

$$\Rightarrow \cos \theta = \pm \frac{\sqrt{3}}{2}$$

Calculator value for  $\cos \theta = \frac{\sqrt{3}}{2}$  is  $30^\circ$

As  $\cos \theta$  is  $\pm$ ,  $\theta$  is in all four quadrants

Solutions are  $30^\circ, 150^\circ, 210^\circ, 330^\circ$

(f)  $5 \cos \theta = 3 \cot \theta$

$$\Rightarrow 5 \cos \theta = 3 \frac{\cos \theta}{\sin \theta}$$

**Note** Do not cancel  $\cos \theta$  on each side. Multiply through by  $\sin \theta$ .

$$\Rightarrow 5 \cos \theta \sin \theta = 3 \cos \theta$$

$$\Rightarrow 5 \cos \theta \sin \theta - 3 \cos \theta = 0$$

$$\Rightarrow \cos \theta (5 \sin \theta - 3) = 0 \quad (\text{factorise})$$

So  $\cos \theta = 0$  or  $\sin \theta = \frac{3}{5}$

Solutions are  $(90^\circ, 270^\circ), (36.9^\circ, 143^\circ) = 36.9^\circ, 90^\circ, 143^\circ, 270^\circ$ .

(g)  $\cot^2 \theta - 8 \tan \theta = 0$

$$\Rightarrow \frac{1}{\tan^2 \theta} - 8 \tan \theta = 0$$

$$\Rightarrow 1 - 8 \tan^3 \theta = 0$$

$$\Rightarrow 8 \tan^3 \theta = 1$$

$$\Rightarrow \tan^3 \theta = \frac{1}{8}$$

$$\Rightarrow \tan \theta = \frac{1}{2}$$

$\tan \theta$  is +ve  $\Rightarrow \theta$  is in 1st and 3rd quadrants

Calculator value is  $26.6^\circ$

Solutions are  $26.6^\circ$  and  $(180^\circ + 26.6^\circ) = 206.6^\circ$  and  $207^\circ$  (3 s.f.).

(h)  $2 \sin \theta = \operatorname{cosec} \theta$

$$\Rightarrow 2 \sin \theta = \frac{1}{\sin \theta}$$

$$\Rightarrow \sin^2 \theta = \frac{1}{2}$$

$$\Rightarrow \sin \theta = \pm \frac{1}{\sqrt{2}}$$

Calculator value for  $\sin^{-1} \frac{1}{\sqrt{2}}$  is  $45^\circ$

Solution are in all four quadrants

Solutions are  $45^\circ, 135^\circ, 225^\circ, 315^\circ$

© Pearson Education Ltd 2008

# Solutionbank

## Edexcel AS and A Level Modular Mathematics

### Exercise C, Question 6

#### Question:

Solve, for values of  $\theta$  in the interval  $-180^\circ \leq \theta \leq 180^\circ$ , the following equations:

(a)  $\operatorname{cosec} \theta = 1$

(b)  $\sec \theta = -3$

(c)  $\cot \theta = 3.45$

(d)  $2 \operatorname{cosec}^2 \theta - 3 \operatorname{cosec} \theta = 0$

(e)  $\sec \theta = 2 \cos \theta$

(f)  $3 \cot \theta = 2 \sin \theta$

(g)  $\operatorname{cosec} 2\theta = 4$

(h)  $2 \cot^2 \theta - \cot \theta - 5 = 0$

#### Solution:

(a)  $\operatorname{cosec} \theta = 1$

$$\Rightarrow \sin \theta = 1$$

$$\Rightarrow \theta = 90^\circ$$

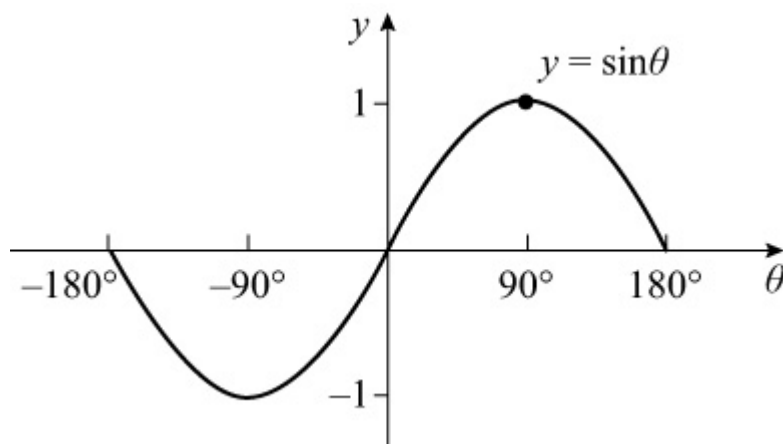

(b)  $\sec \theta = -3$

$$\Rightarrow \cos \theta = -\frac{1}{3}$$

Calculator value for  $\cos^{-1} \left( -\frac{1}{3} \right)$  is  $109^\circ$  (3 s.f.)

$\cos \theta$  is -ve  $\Rightarrow \theta$  is in 2nd and 3rd quadrants

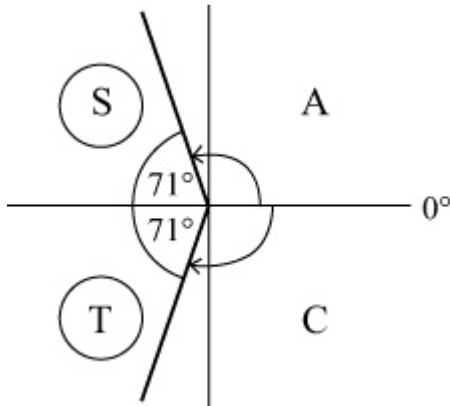

Solutions are  $109^\circ$  and  $-109^\circ$

[If you are not using the quadrant diagram, answer in this case would be  $\cos^{-1} \left( -\frac{1}{3} \right)$  and  $-360^\circ + \cos^{-1} \left( -\frac{1}{3} \right)$ . See key point on page 84.]

(c)  $\cot \theta = 3.45$

$$\Rightarrow \frac{1}{\tan \theta} = 3.45$$

$$\Rightarrow \tan \theta = \frac{1}{3.45} = 0.28985\dots$$

Calculator value for  $\tan^{-1} (0.28985\dots)$  is  $16.16^\circ$

$\tan \theta$  is +ve  $\Rightarrow \theta$  is in 1st and 3rd quadrants

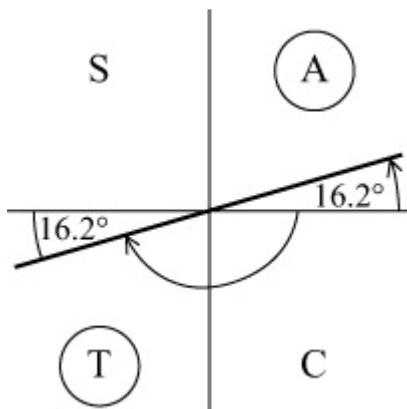

Solutions are  $16.2^\circ$ ,  $-180^\circ + 16.2^\circ = 16.2^\circ$ ,  $-164^\circ$  (3 s.f.)

$$\begin{aligned}
 \text{(d) } 2 \operatorname{cosec}^2 \theta - 3 \operatorname{cosec} \theta &= 0 \\
 \Rightarrow \operatorname{cosec} \theta (2 \operatorname{cosec} \theta - 3) &= 0 \quad (\text{factorise}) \\
 \Rightarrow \operatorname{cosec} \theta = 0 \text{ or } \operatorname{cosec} \theta &= \frac{3}{2} \\
 \Rightarrow \sin \theta = \frac{2}{3} \quad \operatorname{cosec} \theta = 0 &\text{ has no solutions}
 \end{aligned}$$

Calculator value for  $\sin^{-1} \frac{2}{3}$  is  $41.8^\circ$

$\theta$  is in 1st and 2nd quadrants

Solutions are  $41.8^\circ$ ,  $(180 - 41.8)^\circ = 41.8^\circ$ ,  $138^\circ$  (3 s.f.)

$$\begin{aligned}
 \text{(e) } \sec \theta &= 2 \cos \theta \\
 \Rightarrow \frac{1}{\cos \theta} &= 2 \cos \theta \\
 \Rightarrow \cos^2 \theta &= \frac{1}{2} \\
 \Rightarrow \cos \theta &= \pm \frac{1}{\sqrt{2}}
 \end{aligned}$$

Calculator value for  $\cos^{-1} \frac{1}{\sqrt{2}}$  is  $45^\circ$

$\theta$  is in all quadrants, but remember that  $-180^\circ \leq \theta \leq 180^\circ$

Solutions are  $\pm 45^\circ$ ,  $\pm 135^\circ$

$$\begin{aligned}
 \text{(f) } 3 \cot \theta &= 2 \sin \theta \\
 \Rightarrow 3 \frac{\cos \theta}{\sin \theta} &= 2 \sin \theta \\
 \Rightarrow 3 \cos \theta &= 2 \sin^2 \theta \\
 \Rightarrow 3 \cos \theta &= 2(1 - \cos^2 \theta) \quad (\text{use } \sin^2 \theta + \cos^2 \theta \equiv 1) \\
 \Rightarrow 2 \cos^2 \theta + 3 \cos \theta - 2 &= 0 \\
 \Rightarrow (2 \cos \theta - 1)(\cos \theta + 2) &= 0 \\
 \Rightarrow \cos \theta = \frac{1}{2} \text{ or } \cos \theta = -2
 \end{aligned}$$

As  $\cos \theta = -2$  has no solutions,  $\cos \theta = \frac{1}{2}$

Solutions are  $\pm 60^\circ$

$$\begin{aligned}
 \text{(g) } \operatorname{cosec} 2\theta &= 4 \\
 \Rightarrow \sin 2\theta &= \frac{1}{4}
 \end{aligned}$$

Remember that  $-180^\circ \leq \theta \leq 180^\circ$

$$\text{So } -360^\circ \leq 2\theta \leq 360^\circ$$

$$\text{Calculator solution for } 2\theta \text{ is } \sin^{-1} \frac{1}{4} = 14.48^\circ$$

$\sin 2\theta$  is +ve  $\Rightarrow 2\theta$  is in 1st and 2nd quadrants

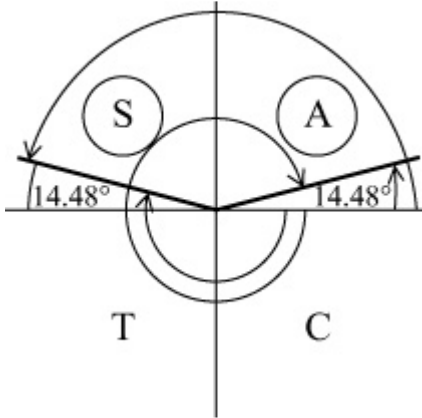

$$2\theta = -194.48^\circ, -345.52^\circ, 14.48^\circ, 165.52^\circ$$

$$\theta = -97.2^\circ, -172.8^\circ, 7.24^\circ, 82.76^\circ = -173^\circ, -97.2^\circ, 7.24^\circ, 82.8^\circ$$

(3 s.f.)

$$(h) 2 \cot^2 \theta - \cot \theta - 5 = 0$$

As this quadratic in  $\cot \theta$  does not factorise, use the quadratic formula

$$\cot \theta = \frac{-b \pm \sqrt{b^2 - 4ac}}{2a}$$

(You could change  $\cot \theta$  to  $\frac{1}{\tan \theta}$  and work with the quadratic

$$5 \tan^2 \theta + \tan \theta - 2 = 0)$$

$$\text{So } \cot \theta = \frac{1 \pm \sqrt{41}}{4} = -1.3507... \text{ or } 1.8507 \dots$$

$$\text{So } \tan \theta = -0.7403... \text{ or } 0.5403 \dots$$

The calculator value for  $\tan \theta = -0.7403...$  is  $\theta = -36.51^\circ$

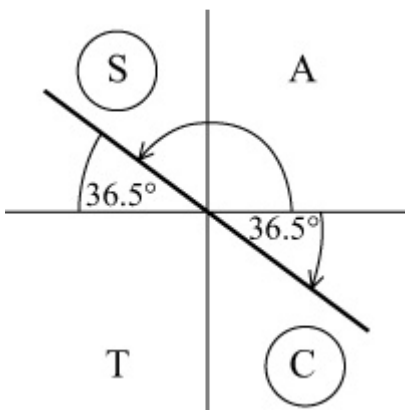

Solution are  $-36.5^\circ, +143^\circ$  (3 s.f.).

The calculator value for  $\tan \theta = 0.5403\dots$  is  $\theta = 28.38^\circ$

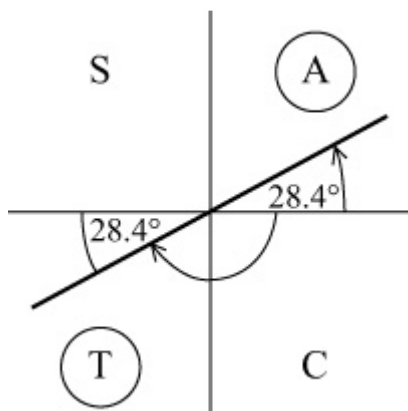

Solution are  $28.4^\circ$ ,  $(-180 + 28.4)^\circ$

Total set of solutions is  $-152^\circ$ ,  $-36.5^\circ$ ,  $28.4^\circ$ ,  $143^\circ$  (3 s.f.)

© Pearson Education Ltd 2008

# Solutionbank

## Edexcel AS and A Level Modular Mathematics

### Exercise C, Question 7

#### Question:

Solve the following equations for values of  $\theta$  in the interval  $0 \leq \theta \leq 2\pi$ .  
Give your answers in terms of  $\pi$ .

(a)  $\sec \theta = -1$

(b)  $\cot \theta = -\sqrt{3}$

(c)  $\operatorname{cosec} \frac{1}{2}\theta = \frac{2\sqrt{3}}{3}$

(d)  $\sec \theta = \sqrt{2} \tan \theta \quad \left( \theta \neq \frac{\pi}{2}, \theta \neq \frac{3\pi}{2} \right)$

#### Solution:

(a)  $\sec \theta = -1$

$$\Rightarrow \cos \theta = -1$$

$$\Rightarrow \theta = \pi \quad (\text{refer to graph of } y = \cos \theta)$$

(b)  $\cot \theta = -\sqrt{3}$

$$\Rightarrow \tan \theta = -\frac{1}{\sqrt{3}}$$

Calculator solution is  $-\frac{\pi}{6}$   $\left( \text{you should know that } \tan \frac{\pi}{6} = \frac{1}{\sqrt{3}} \right)$

$-\frac{\pi}{6}$  is not in the interval

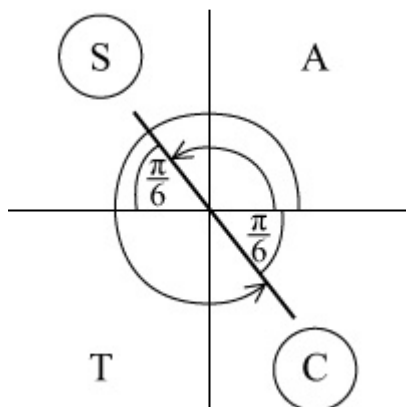



Solution are  $\pi - \frac{\pi}{6}, 2\pi - \frac{\pi}{6} = \frac{5\pi}{6}, \frac{11\pi}{6}$

$$(c) \operatorname{cosec} \frac{1}{2}\theta = \frac{2\sqrt{3}}{3}$$

$$\Rightarrow \sin \frac{1}{2}\theta = \frac{3}{2\sqrt{3}} = \frac{\sqrt{3}}{2}$$

Remember that  $0 \leq \theta \leq 2\pi$

so  $0 \leq \frac{1}{2}\theta \leq \pi$

First solution for  $\sin \frac{1}{2}\theta = \frac{\sqrt{3}}{2}$  is  $\frac{1}{2}\theta = \frac{\pi}{3}$

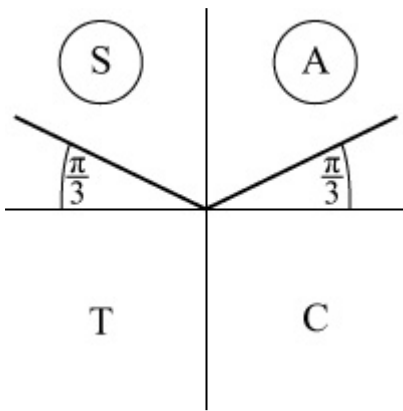

$$\text{So } \frac{1}{2}\theta = \frac{\pi}{3}, \frac{2\pi}{3}$$

$$\Rightarrow \theta = \frac{2\pi}{3}, \frac{4\pi}{3}$$

$$(d) \sec \theta = \sqrt{2} \tan \theta$$

$$\Rightarrow \frac{1}{\cos \theta} = \sqrt{2} \frac{\sin \theta}{\cos \theta}$$

$$\Rightarrow 1 = \sqrt{2} \sin \theta \quad (\cos \theta \neq 0)$$

$$\Rightarrow \sin \theta = \frac{1}{\sqrt{2}}$$

Solutions are  $\frac{\pi}{4}, \frac{3\pi}{4}$

# Solutionbank

## Edexcel AS and A Level Modular Mathematics

### Exercise C, Question 8

#### Question:

In the diagram  $AB = 6$  cm is the diameter of the circle and  $BT$  is the tangent to the circle at  $B$ . The chord  $AC$  is extended to meet this tangent at  $D$  and

$$\angle DAB = \theta.$$

(a) Show that  $CD = 6 (\sec \theta - \cos \theta)$  .

(b) Given that  $CD = 16$  cm, calculate the length of the chord  $AC$ .

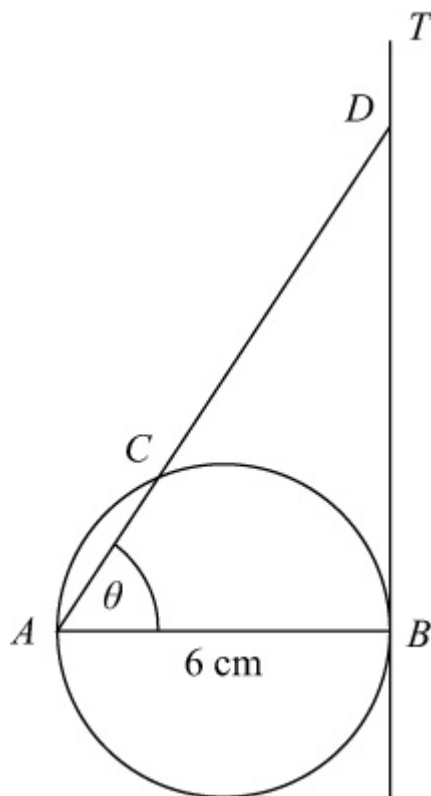

#### Solution:

(a) In right-angled triangle  $ABD$

$$\frac{AB}{AD} = \cos \theta$$

$$\Rightarrow AD = \frac{6}{\cos \theta} = 6 \sec \theta$$

In right-angled triangle  $ACB$

$$\frac{AC}{AB} = \cos \theta$$

$$\Rightarrow AC = 6 \cos \theta$$

$$DC = AD - AC = 6 \sec \theta - 6 \cos \theta = 6 (\sec \theta - \cos \theta)$$

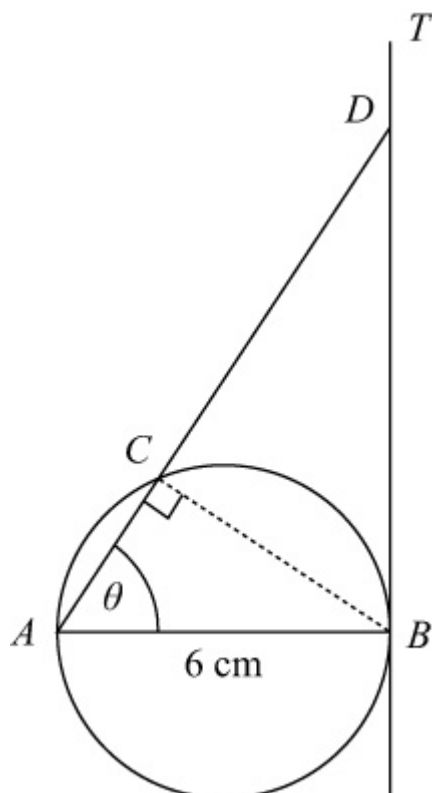

(b) As  $16 = 6 \sec \theta - 6 \cos \theta$

$$\Rightarrow 8 = \frac{3}{\cos \theta} - 3 \cos \theta$$

$$\Rightarrow 8 \cos \theta = 3 - 3 \cos^2 \theta$$

$$\Rightarrow 3 \cos^2 \theta + 8 \cos \theta - 3 = 0$$

$$\Rightarrow (3 \cos \theta - 1) (\cos \theta + 3) = 0$$

$$\Rightarrow \cos \theta = \frac{1}{3} \quad \text{as } \cos \theta \neq -3$$

From (a)  $AC = 6 \cos \theta = 6 \times \frac{1}{3} = 2 \text{ cm}$

# Solutionbank

## Edexcel AS and A Level Modular Mathematics

### Exercise D, Question 1

#### Question:

Simplify each of the following expressions:

(a)  $1 + \tan^2 \frac{1}{2}\theta$

(b)  $(\sec \theta - 1)(\sec \theta + 1)$

(c)  $\tan^2 \theta (\operatorname{cosec}^2 \theta - 1)$

(d)  $(\sec^2 \theta - 1) \cot \theta$

(e)  $(\operatorname{cosec}^2 \theta - \cot^2 \theta)^2$

(f)  $2 - \tan^2 \theta + \sec^2 \theta$

(g)  $\frac{\tan \theta \sec \theta}{1 + \tan^2 \theta}$

(h)  $(1 - \sin^2 \theta)(1 + \tan^2 \theta)$

(i)  $\frac{\operatorname{cosec} \theta \cot \theta}{1 + \cot^2 \theta}$

(j)  $(\sec^4 \theta - 2 \sec^2 \theta \tan^2 \theta + \tan^4 \theta)$

(k)  $4 \operatorname{cosec}^2 2\theta + 4 \operatorname{cosec}^2 2\theta \cot^2 2\theta$

#### Solution:

(a) Use  $1 + \tan^2 \theta = \sec^2 \theta$  with  $\theta$  replaced with  $\frac{1}{2}\theta$ .

$$1 + \tan^2 \left( \frac{1}{2}\theta \right) = \sec^2 \left( \frac{1}{2}\theta \right)$$

(b)  $(\sec \theta - 1)(\sec \theta + 1)$  (multiply out)  
 $= \sec^2 \theta - 1$   
 $= (1 + \tan^2 \theta) - 1$

$$= \tan^2 \theta$$

$$\begin{aligned} \text{(c) } & \tan^2 \theta (\operatorname{cosec}^2 \theta - 1) \\ &= \tan^2 \theta [ (1 + \cot^2 \theta) - 1 ] \\ &= \tan^2 \theta \cot^2 \theta \\ &= \tan^2 \theta \times \frac{1}{\tan^2 \theta} \\ &= 1 \end{aligned}$$

$$\begin{aligned} \text{(d) } & (\sec^2 \theta - 1) \cot \theta \\ &= \tan^2 \theta \cot \theta \\ &= \tan^2 \theta \times \frac{1}{\tan \theta} \\ &= \tan \theta \end{aligned}$$

$$\begin{aligned} \text{(e) } & (\operatorname{cosec}^2 \theta - \cot^2 \theta)^2 \\ &= [ (1 + \cot^2 \theta) - \cot^2 \theta ]^2 \\ &= 1^2 \\ &= 1 \end{aligned}$$

$$\begin{aligned} \text{(f) } & 2 - \tan^2 \theta + \sec^2 \theta \\ &= 2 - \tan^2 \theta + (1 + \tan^2 \theta) \\ &= 2 - \tan^2 \theta + 1 + \tan^2 \theta \\ &= 3 \end{aligned}$$

$$\begin{aligned} \text{(g) } & \frac{\tan \theta \sec \theta}{1 + \tan^2 \theta} \\ &= \frac{\tan \theta \sec \theta}{\sec^2 \theta} \\ &= \frac{\tan \theta}{\sec \theta} \\ &= \tan \theta \cos \theta \\ &= \frac{\sin \theta}{\cos \theta} \times \cos \theta \\ &= \sin \theta \end{aligned}$$

$$\begin{aligned} \text{(h) } & (1 - \sin^2 \theta) (1 + \tan^2 \theta) \\ &= \cos^2 \theta \times \sec^2 \theta \end{aligned}$$

$$= \cos^2 \theta \times \frac{1}{\cos^2 \theta}$$

$$= 1$$

$$(i) \frac{\operatorname{cosec} \theta \cot \theta}{1 + \cot^2 \theta}$$

$$= \frac{\operatorname{cosec} \theta \cot \theta}{\operatorname{cosec}^2 \theta}$$

$$= \frac{1}{\operatorname{cosec} \theta} \times \cot \theta$$

$$= \frac{\sin \theta}{1} \times \frac{\cos \theta}{\sin \theta}$$

$$= \cos \theta$$

$$(j) \sec^4 \theta - 2 \sec^2 \theta \tan^2 \theta + \tan^4 \theta$$

$$= (\sec^2 \theta - \tan^2 \theta)^2 \quad (\text{factorise})$$

$$= [ (1 + \tan^2 \theta) - \tan^2 \theta ]^2$$

$$= 1^2$$

$$= 1$$

$$(k) 4 \operatorname{cosec}^2 2\theta + 4 \operatorname{cosec}^2 2\theta \cot^2 2\theta$$

$$= 4 \operatorname{cosec}^2 2\theta (1 + \cot^2 2\theta)$$

$$= 4 \operatorname{cosec}^2 2\theta \operatorname{cosec}^2 2\theta$$

$$= 4 \operatorname{cosec}^4 2\theta$$

# Solutionbank

## Edexcel AS and A Level Modular Mathematics

Exercise D, Question 2

### Question:

Given that  $\operatorname{cosec} x = \frac{k}{\operatorname{cosec} x}$ , where  $k > 1$ , find, in terms of  $k$ , possible values of  $\cot x$ .

### Solution:

$$\operatorname{cosec} x = \frac{k}{\operatorname{cosec} x}$$

$$\Rightarrow \operatorname{cosec}^2 x = k$$

$$\Rightarrow 1 + \cot^2 x = k$$

$$\Rightarrow \cot^2 x = k - 1$$

$$\Rightarrow \cot x = \pm \sqrt{k - 1}$$

© Pearson Education Ltd 2008

# Solutionbank

## Edexcel AS and A Level Modular Mathematics

### Exercise D, Question 3

#### Question:

Given that  $\cot \theta = -\sqrt{3}$ , and that  $90^\circ < \theta < 180^\circ$ , find the exact value of

(a)  $\sin \theta$

(b)  $\cos \theta$

#### Solution:

(a)  $\cot \theta = -\sqrt{3} \quad 90^\circ < \theta < 180^\circ$

$$\Rightarrow 1 + \cot^2 \theta = 1 + 3 = 4$$

$$\Rightarrow \operatorname{cosec}^2 \theta = 4$$

$$\Rightarrow \sin^2 \theta = \frac{1}{4}$$

$$\Rightarrow \sin \theta = \frac{1}{2} \quad (\text{as } \theta \text{ is in 2nd quadrant, } \sin \theta \text{ is +ve)}$$

(b) Using  $\sin^2 \theta + \cos^2 \theta = 1$

$$\Rightarrow \cos^2 \theta = 1 - \sin^2 \theta = 1 - \frac{1}{4} = \frac{3}{4}$$

$$\Rightarrow \cos \theta = -\frac{\sqrt{3}}{2} \quad (\text{as } \theta \text{ is in 2nd quadrant, } \cos \theta \text{ is -ve)}$$



# Solutionbank

## Edexcel AS and A Level Modular Mathematics

### Exercise D, Question 4

#### Question:

Given that  $\tan \theta = \frac{3}{4}$ , and that  $180^\circ < \theta < 270^\circ$ , find the exact value of

(a)  $\sec \theta$

(b)  $\cos \theta$

(c)  $\sin \theta$

#### Solution:

$$\tan \theta = \frac{3}{4} \quad 180^\circ < \theta < 270^\circ$$

Draw right-angled triangle where  $\tan \theta = \frac{3}{4}$

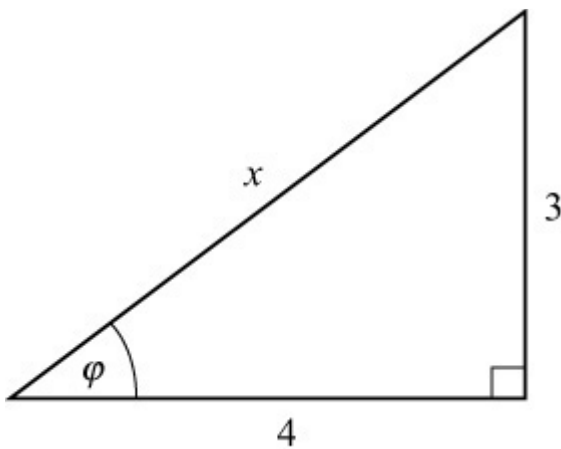

Using Pythagoras' theorem,  $x = 5$

$$\text{So } \cos \theta = \frac{4}{5} \text{ and } \sin \theta = \frac{3}{5}$$

As  $\theta$  is in 3rd quadrant, both  $\sin \theta$  and  $\cos \theta$  are  $-ve$ .

$$\text{So } \sin \theta = -\frac{3}{5}, \cos \theta = -\frac{4}{5}$$

(a)  $\sec \theta = \frac{1}{\cos \theta} = -\frac{5}{4}$

(b)  $\cos \theta = -\frac{4}{5}$

(c)  $\sin \theta = -\frac{3}{5}$

© Pearson Education Ltd 2008

# Solutionbank

## Edexcel AS and A Level Modular Mathematics

### Exercise D, Question 5

#### Question:

Given that  $\cos \theta = \frac{24}{25}$ , and that  $\theta$  is a reflex angle, find the exact value of

(a)  $\tan \theta$

(b)  $\operatorname{cosec} \theta$

#### Solution:

$$\cos \theta = \frac{24}{25}, \theta \text{ reflex}$$

As  $\cos \theta$  is +ve and  $\theta$  reflex,  $\theta$  is in the 4th quadrant.

Use right-angled triangle where  $\cos \theta = \frac{24}{25}$

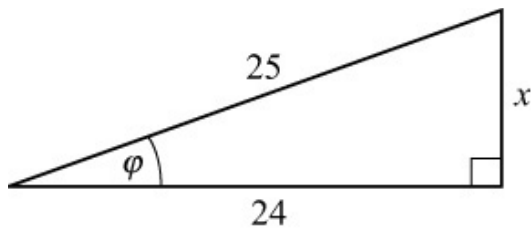

Using Pythagoras' theorem,

$$25^2 = x^2 + 24^2$$

$$\Rightarrow x^2 = 25^2 - 24^2 = 49$$

$$\Rightarrow x = 7$$

So  $\tan \phi = \frac{7}{24}$  and  $\sin \phi = \frac{7}{25}$

As  $\theta$  is in 4th quadrant,

(a)  $\tan \theta = -\frac{7}{24}$

(b)  $\operatorname{cosec} \theta = \frac{1}{\sin \theta} = -\frac{1}{\frac{7}{25}} = -\frac{25}{7}$

# Solutionbank

## Edexcel AS and A Level Modular Mathematics

### Exercise D, Question 6

#### Question:

Prove the following identities:

$$(a) \sec^4 \theta - \tan^4 \theta \equiv \sec^2 \theta + \tan^2 \theta$$

$$(b) \operatorname{cosec}^2 x - \sin^2 x \equiv \cot^2 x + \cos^2 x$$

$$(c) \sec^2 A (\cot^2 A - \cos^2 A) \equiv \cot^2 A$$

$$(d) 1 - \cos^2 \theta \equiv (\sec^2 \theta - 1) (1 - \sin^2 \theta)$$

$$(e) \frac{1 - \tan^2 A}{1 + \tan^2 A} \equiv 1 - 2 \sin^2 A$$

$$(f) \sec^2 \theta + \operatorname{cosec}^2 \theta \equiv \sec^2 \theta \operatorname{cosec}^2 \theta$$

$$(g) \operatorname{cosec} A \sec^2 A \equiv \operatorname{cosec} A + \tan A \sec A$$

$$(h) (\sec \theta - \sin \theta) (\sec \theta + \sin \theta) \equiv \tan^2 \theta + \cos^2 \theta$$

#### Solution:

$$\begin{aligned} (a) \text{L.H.S.} &\equiv \sec^4 \theta - \tan^4 \theta \\ &\equiv (\sec^2 \theta - \tan^2 \theta) (\sec^2 \theta + \tan^2 \theta) \quad (\text{difference of two squares}) \\ &\equiv (1) (\sec^2 \theta + \tan^2 \theta) \quad (\text{as } 1 + \tan^2 \theta \equiv \sec^2 \theta \Rightarrow \sec^2 \theta - \tan^2 \theta \equiv 1) \\ &\equiv \sec^2 \theta + \tan^2 \theta \equiv \text{R.H.S.} \end{aligned}$$

$$\begin{aligned} (b) \text{L.H.S.} &\equiv \operatorname{cosec}^2 x - \sin^2 x \\ &\equiv (1 + \cot^2 x) - (1 - \cos^2 x) \\ &\equiv 1 + \cot^2 x - 1 + \cos^2 x \\ &\equiv \cot^2 x + \cos^2 x \equiv \text{R.H.S.} \end{aligned}$$

$$(c) \text{L.H.S.} \equiv \sec^2 A (\cot^2 A - \cos^2 A)$$

$$\begin{aligned}
&\equiv \frac{1}{\cos^2 A} \left( \frac{\cos^2 A}{\sin^2 A} - \cos^2 A \right) \\
&\equiv \frac{1}{\sin^2 A} - 1 \\
&\equiv \operatorname{cosec}^2 A - 1 \quad (\text{use } 1 + \cot^2 \theta = \operatorname{cosec}^2 \theta) \\
&\equiv 1 + \cot^2 A - 1 \\
&\equiv \cot^2 A \equiv \text{R.H.S.}
\end{aligned}$$

$$\begin{aligned}
\text{(d) R.H.S.} &\equiv (\sec^2 \theta - 1) (1 - \sin^2 \theta) \\
&\equiv \tan^2 \theta \times \cos^2 \theta \quad (\text{use } 1 + \tan^2 \theta \equiv \sec^2 \theta \text{ and} \\
&\cos^2 \theta + \sin^2 \theta \equiv 1) \\
&\equiv \frac{\sin^2 \theta}{\cos^2 \theta} \times \cos^2 \theta \\
&\equiv \sin^2 \theta \\
&\equiv 1 - \cos^2 \theta \equiv \text{L.H.S.}
\end{aligned}$$

$$\begin{aligned}
\text{(e) L.H.S.} &\equiv \frac{1 - \tan^2 A}{1 + \tan^2 A} \\
&\equiv \frac{1 - \tan^2 A}{\sec^2 A} \\
&\equiv \frac{1}{\sec^2 A} (1 - \tan^2 A) \\
&\equiv \cos^2 A \left( 1 - \frac{\sin^2 A}{\cos^2 A} \right) \\
&\equiv \cos^2 A - \sin^2 A \\
&\equiv (1 - \sin^2 A) - \sin^2 A \\
&\equiv 1 - 2 \sin^2 A \equiv \text{R.H.S.}
\end{aligned}$$

$$\begin{aligned}
\text{(f) R.H.S.} &\equiv \sec^2 \theta \operatorname{cosec}^2 \theta \\
&\equiv \sec^2 \theta (1 + \cot^2 \theta) \\
&\equiv \sec^2 \theta + \frac{1}{\cos^2 \theta} \times \frac{\cos^2 \theta}{\sin^2 \theta} \\
&\equiv \sec^2 \theta + \frac{1}{\sin^2 \theta} \\
&\equiv \sec^2 \theta + \operatorname{cosec}^2 \theta \equiv \text{L.H.S.}
\end{aligned}$$

$$\text{(g) L.H.S.} \equiv \operatorname{cosec} A \sec^2 A$$

$$\begin{aligned}
&\equiv \operatorname{cosec} A ( 1 + \tan^2 A ) \\
&\equiv \operatorname{cosec} A + \frac{1}{\sin A} \times \frac{\sin^2 A}{\cos^2 A} \\
&\equiv \operatorname{cosec} A + \frac{\sin A}{\cos^2 A} \\
&\equiv \operatorname{cosec} A + \frac{\sin A}{\cos A} \times \frac{1}{\cos A} \\
&\equiv \operatorname{cosec} A + \tan A \sec A \equiv \text{R.H.S.}
\end{aligned}$$

$$\begin{aligned}
\text{(h) L.H.S.} &\equiv ( \sec \theta - \sin \theta ) ( \sec \theta + \sin \theta ) \\
&\equiv \sec^2 \theta - \sin^2 \theta \\
&\equiv ( 1 + \tan^2 \theta ) - ( 1 - \cos^2 \theta ) \\
&\equiv 1 + \tan^2 \theta - 1 + \cos^2 \theta \\
&\equiv \tan^2 \theta + \cos^2 \theta \equiv \text{R.H.S.}
\end{aligned}$$

# Solutionbank

## Edexcel AS and A Level Modular Mathematics

Exercise D, Question 7

### Question:

Given that  $3 \tan^2 \theta + 4 \sec^2 \theta = 5$ , and that  $\theta$  is obtuse, find the exact value of  $\sin \theta$ .

### Solution:

$$\begin{aligned}3 \tan^2 \theta + 4 \sec^2 \theta &= 5 \\ \Rightarrow 3 \tan^2 \theta + 4(1 + \tan^2 \theta) &= 5 \\ \Rightarrow 3 \tan^2 \theta + 4 + 4 \tan^2 \theta &= 5 \\ \Rightarrow 7 \tan^2 \theta &= 1 \\ \Rightarrow \tan^2 \theta &= \frac{1}{7} \\ \Rightarrow \cot^2 \theta &= 7 \\ \Rightarrow \operatorname{cosec}^2 \theta - 1 &= 7 \\ \Rightarrow \operatorname{cosec}^2 \theta &= 8 \\ \Rightarrow \sin^2 \theta &= \frac{1}{8}\end{aligned}$$

As  $\theta$  is obtuse (2nd quadrant), so  $\sin \theta$  is +ve.

$$\text{So } \sin \theta = \sqrt{\frac{1}{8}} = \frac{1}{2\sqrt{2}} = \frac{\sqrt{2}}{4}$$

# Solutionbank

## Edexcel AS and A Level Modular Mathematics

### Exercise D, Question 8

#### Question:

Giving answers to 3 significant figures where necessary, solve the following equations in the given intervals:

(a)  $\sec^2 \theta = 3 \tan \theta, 0 \leq \theta \leq 360^\circ$

(b)  $\tan^2 \theta - 2 \sec \theta + 1 = 0, -\pi \leq \theta \leq \pi$

(c)  $\operatorname{cosec}^2 \theta + 1 = 3 \cot \theta, -180^\circ \leq \theta \leq 180^\circ$

(d)  $\cot \theta = 1 - \operatorname{cosec}^2 \theta, 0 \leq \theta \leq 2\pi$

(e)  $3 \sec \frac{1}{2}\theta = 2 \tan^2 \frac{1}{2}\theta, 0 \leq \theta \leq 360^\circ$

(f)  $(\sec \theta - \cos \theta)^2 = \tan \theta - \sin^2 \theta, 0 \leq \theta \leq \pi$

(g)  $\tan^2 2\theta = \sec 2\theta - 1, 0 \leq \theta \leq 180^\circ$

(h)  $\sec^2 \theta - (1 + \sqrt{3}) \tan \theta + \sqrt{3} = 1, 0 \leq \theta \leq 2\pi$

#### Solution:

(a)  $\sec^2 \theta = 3 \tan \theta \quad 0 \leq \theta \leq 360^\circ$

$$\Rightarrow 1 + \tan^2 \theta = 3 \tan \theta$$

$$\Rightarrow \tan^2 \theta - 3 \tan \theta + 1 = 0$$

$$\tan \theta = \frac{3 \pm \sqrt{5}}{2} \quad (\text{equation does not factorise}).$$

For  $\tan \theta = \frac{3 + \sqrt{5}}{2}$ , calculator value is  $69.1^\circ$



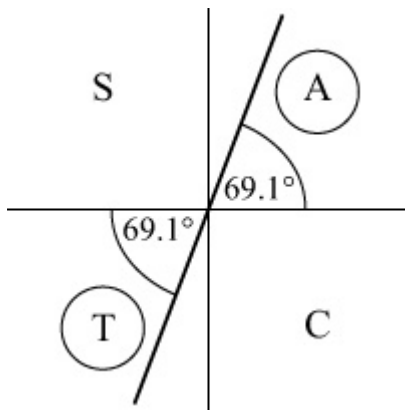

Solutions are  $69.1^\circ$ ,  $249^\circ$

For  $\tan \theta = \frac{3 - \sqrt{5}}{2}$ , calculator value is  $20.9^\circ$

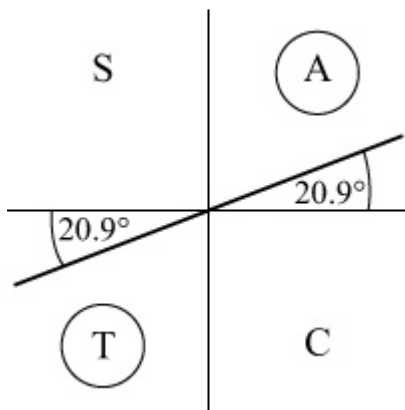

Solutions are  $20.9^\circ$ ,  $201^\circ$

Set of solutions:  $20.9^\circ$ ,  $69.1^\circ$ ,  $201^\circ$ ,  $249^\circ$  (3 s.f.)

$$(b) \tan^2 \theta - 2 \sec \theta + 1 = 0 \quad -\pi \leq \theta \leq \pi$$

$$\Rightarrow (\sec^2 \theta - 1) - 2 \sec \theta + 1 = 0$$

$$\Rightarrow \sec^2 \theta - 2 \sec \theta = 0$$

$$\Rightarrow \sec \theta (\sec \theta - 2) = 0$$

$$\Rightarrow \sec \theta = 2 \quad (\text{as } \sec \theta \text{ cannot be } 0)$$

$$\Rightarrow \cos \theta = \frac{1}{2}$$

$$\Rightarrow \theta = -\frac{\pi}{3}, \frac{\pi}{3}$$

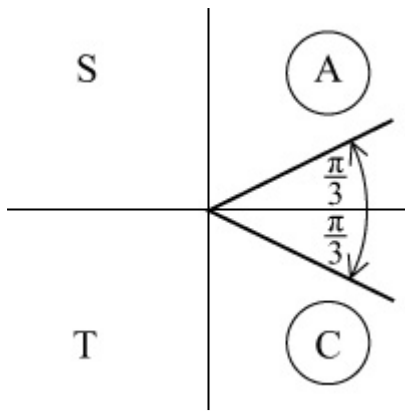

$$\begin{aligned}
 \text{(c) } \operatorname{cosec}^2 \theta + 1 &= 3 \cot \theta & -180^\circ \leq \theta \leq 180^\circ \\
 \Rightarrow (1 + \cot^2 \theta) + 1 &= 3 \cot \theta \\
 \Rightarrow \cot^2 \theta - 3 \cot \theta + 2 &= 0 \\
 \Rightarrow (\cot \theta - 1)(\cot \theta - 2) &= 0 \\
 \Rightarrow \cot \theta = 1 \text{ or } \cot \theta = 2 \\
 \Rightarrow \tan \theta = 1 \text{ or } \tan \theta = \frac{1}{2}
 \end{aligned}$$

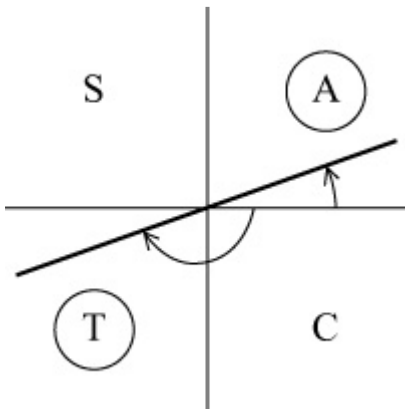

$$\begin{aligned}
 \tan \theta = 1 &\Rightarrow \theta = -135^\circ, 45^\circ \\
 \tan \theta = \frac{1}{2} &\Rightarrow \theta = -153^\circ, 26.6^\circ
 \end{aligned}$$

$$\begin{aligned}
 \text{(d) } \cot \theta = 1 - \operatorname{cosec}^2 \theta & \quad 0 \leq \theta \leq 2\pi \\
 \Rightarrow \cot \theta = 1 - (1 + \cot^2 \theta) \\
 \Rightarrow \cot \theta = -\cot^2 \theta \\
 \Rightarrow \cot^2 \theta + \cot \theta = 0 \\
 \Rightarrow \cot \theta (\cot \theta + 1) = 0 \\
 \Rightarrow \cot \theta = 0 \text{ or } \cot \theta = -1
 \end{aligned}$$

For  $\cot \theta = 0$  refer to graph:  $\theta = \frac{\pi}{2}, \frac{3\pi}{2}$

For  $\cot \theta = -1, \tan \theta = -1$

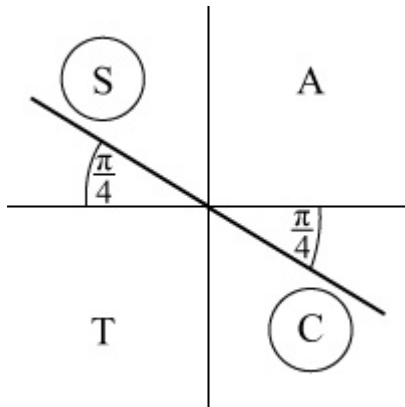

So  $\theta = \frac{3\pi}{4}, \frac{7\pi}{4}$

Set of solutions:  $\frac{\pi}{2}, \frac{3\pi}{4}, \frac{3\pi}{2}, \frac{7\pi}{4}$

$$(e) 3 \sec \frac{1}{2}\theta = 2 \tan^2 \frac{1}{2}\theta \quad 0 \leq \theta \leq 360^\circ$$

$$\Rightarrow 3 \sec \frac{1}{2}\theta = 2 \left( \sec^2 \frac{1}{2}\theta - 1 \right) \quad (\text{use } 1 + \tan^2 A \equiv \sec^2 A \text{ with}$$

$$A = \frac{1}{2}\theta)$$

$$\Rightarrow 2 \sec^2 \frac{1}{2}\theta - 3 \sec \frac{1}{2}\theta - 2 = 0$$

$$\Rightarrow \left( 2 \sec \frac{1}{2}\theta + 1 \right) \left( \sec \frac{1}{2}\theta - 2 \right) = 0$$

$$\Rightarrow \sec \frac{1}{2}\theta = -\frac{1}{2} \text{ or } \sec \frac{1}{2}\theta = 2$$

Only  $\sec \frac{1}{2}\theta = 2$  applies as  $\sec A \leq -1$  or  $\sec A \geq 1$

$$\Rightarrow \cos \frac{1}{2}\theta = \frac{1}{2}$$

As  $0 \leq \theta \leq 360^\circ$

so  $0 \leq \frac{1}{2}\theta \leq 180^\circ$

Calculator value is  $60^\circ$

This is the only value in the interval.

$$\text{So } \frac{1}{2}\theta = 60^\circ$$

$$\Rightarrow \theta = 120^\circ$$

$$(f) (\sec \theta - \cos \theta)^2 = \tan \theta - \sin^2 \theta \quad 0 \leq \theta \leq \pi$$

$$\Rightarrow \sec^2 \theta - 2 \sec \theta \cos \theta + \cos^2 \theta = \tan \theta - \sin^2 \theta$$

$$\Rightarrow \sec^2 \theta - 2 + \cos^2 \theta = \tan \theta - \sin^2 \theta \quad \left( \begin{array}{l} \sec \theta \cos \theta = \\ \frac{1}{\cos \theta} \times \cos \theta = 1 \end{array} \right)$$

$$\Rightarrow (1 + \tan^2 \theta) - 2 + (\cos^2 \theta + \sin^2 \theta) = \tan \theta$$

$$\Rightarrow 1 + \tan^2 \theta - 2 + 1 = \tan \theta$$

$$\Rightarrow \tan^2 \theta - \tan \theta = 0$$

$$\Rightarrow \tan \theta (\tan \theta - 1) = 0$$

$$\Rightarrow \tan \theta = 0 \text{ or } \tan \theta = 1$$

$$\tan \theta = 0 \Rightarrow \theta = 0, \pi$$

$$\tan \theta = 1 \Rightarrow \theta = \frac{\pi}{4}$$

$$\text{Set of solutions: } 0, \frac{\pi}{4}, \pi$$

$$(g) \tan^2 2\theta = \sec 2\theta - 1 \quad 0 \leq \theta \leq 180^\circ$$

$$\Rightarrow \sec^2 2\theta - 1 = \sec 2\theta - 1$$

$$\Rightarrow \sec^2 2\theta - \sec 2\theta = 0$$

$$\Rightarrow \sec 2\theta (\sec 2\theta - 1) = 0$$

$$\Rightarrow \sec 2\theta = 0 \text{ (not possible) or } \sec 2\theta = 1$$

$$\Rightarrow \cos 2\theta = 1 \quad 0 \leq 2\theta \leq 360^\circ$$

Refer to graph of  $y = \cos \theta$

$$\Rightarrow 2\theta = 0^\circ, 360^\circ$$

$$\Rightarrow \theta = 0^\circ, 180^\circ$$

$$(h) \sec^2 \theta - (1 + \sqrt{3}) \tan \theta + \sqrt{3} = 1 \quad 0 \leq \theta \leq 2\pi$$

$$\Rightarrow (1 + \tan^2 \theta) - (1 + \sqrt{3}) \tan \theta + \sqrt{3} = 1$$

$$\Rightarrow \tan^2 \theta - (1 + \sqrt{3}) \tan \theta + \sqrt{3} = 0$$

$$\Rightarrow (\tan \theta - \sqrt{3}) (\tan \theta - 1) = 0$$

$$\Rightarrow \tan \theta = \sqrt{3} \text{ or } \tan \theta = 1$$

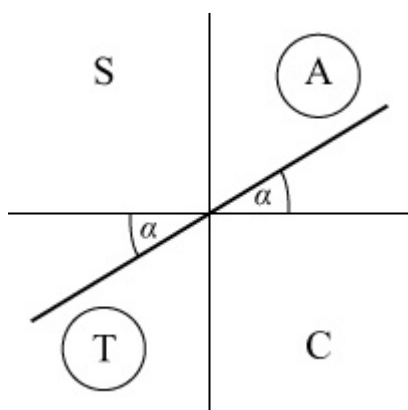

First answer ( $\alpha$ ) for  $\tan \theta = \sqrt{3}$  is  $\frac{\pi}{3}$

Second solution is  $\pi + \frac{\pi}{3} = \frac{4\pi}{3}$

First answer for  $\tan \theta = 1$  is  $\frac{\pi}{4}$

Second solution is  $\pi + \frac{\pi}{4} = \frac{5\pi}{4}$

Set of solutions:  $\frac{\pi}{4}, \frac{\pi}{3}, \frac{5\pi}{4}, \frac{4\pi}{3}$

# Solutionbank

## Edexcel AS and A Level Modular Mathematics

### Exercise D, Question 9

#### Question:

Given that  $\tan^2 k = 2 \sec k$ ,

(a) find the value of  $\sec k$ .

(b) deduce that  $\cos k = \sqrt{2} - 1$

(c) hence solve, in the interval  $0 \leq k \leq 360^\circ$ ,  $\tan^2 k = 2 \sec k$ , giving your answers to 1 decimal place.

#### Solution:

(a)  $\tan^2 k = 2 \sec k$

$$\Rightarrow (\sec^2 k - 1) = 2 \sec k$$

$$\Rightarrow \sec^2 k - 2 \sec k - 1 = 0$$

$$\Rightarrow \sec k = \frac{2 \pm \sqrt{8}}{2} = \frac{2 \pm 2\sqrt{2}}{2} = 1 \pm \sqrt{2}$$

As  $\sec k$  has no values between  $-1$  and  $1$

$$\sec k = 1 + \sqrt{2}$$

$$(b) \cos k = \frac{1}{1 + \sqrt{2}} = \frac{\sqrt{2} - 1}{(1 + \sqrt{2})(\sqrt{2} - 1)} = \frac{\sqrt{2} - 1}{2 - 1} = \sqrt{2} - 1$$

(c) Solutions of  $\tan^2 k = 2 \sec k$ ,  $0 \leq k \leq 360^\circ$   
are solutions of  $\cos k = \sqrt{2} - 1$

Calculator solution is  $65.5^\circ$

$$\Rightarrow k = 65.5^\circ, 360^\circ - 65.5^\circ = 65.5^\circ, 294.5^\circ \text{ (1 d.p.)}$$

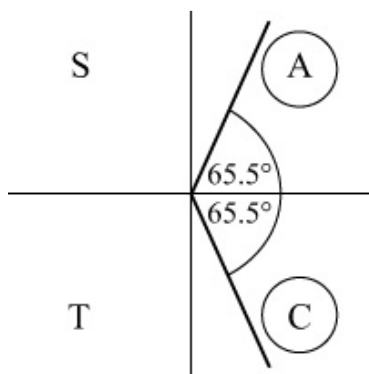

# Solutionbank

## Edexcel AS and A Level Modular Mathematics

### Exercise D, Question 10

#### Question:

Given that  $a = 4 \sec x$ ,  $b = \cos x$  and  $c = \cot x$ ,

(a) express  $b$  in terms of  $a$

(b) show that  $c^2 = \frac{16}{a^2 - 16}$

#### Solution:

(a) As  $a = 4 \sec x$

$$\Rightarrow \sec x = \frac{a}{4}$$

$$\Rightarrow \cos x = \frac{4}{a}$$

As  $\cos x = b$

$$\Rightarrow b = \frac{4}{a}$$

(b)  $c = \cot x$

$$\Rightarrow c^2 = \cot^2 x$$

$$\Rightarrow \frac{1}{c^2} = \tan^2 x$$

$$\Rightarrow \frac{1}{c^2} = \sec^2 x - 1 \quad (\text{use } 1 + \tan^2 x \equiv \sec^2 x)$$

$$\Rightarrow \frac{1}{c^2} = \frac{a^2}{16} - 1 \quad \left( \sec x = \frac{a}{4} \right)$$

$$\Rightarrow 16 = a^2 c^2 - 16c^2 \quad (\text{multiply by } 16c^2)$$

$$\Rightarrow c^2 (a^2 - 16) = 16$$

$$\Rightarrow c^2 = \frac{16}{a^2 - 16}$$

# Solutionbank

## Edexcel AS and A Level Modular Mathematics

### Exercise D, Question 11

#### Question:

Given that  $x = \sec \theta + \tan \theta$ ,

(a) show that  $\frac{1}{x} = \sec \theta - \tan \theta$ .

(b) Hence express  $x^2 + \frac{1}{x^2} + 2$  in terms of  $\theta$ , in its simplest form.

#### Solution:

(a)  $x = \sec \theta + \tan \theta$

$$\frac{1}{x} = \frac{1}{\sec \theta + \tan \theta}$$

$$= \frac{\sec \theta - \tan \theta}{(\sec \theta + \tan \theta)(\sec \theta - \tan \theta)}$$

$$= \frac{\sec \theta - \tan \theta}{\sec^2 \theta - \tan^2 \theta}$$

$$= \sec \theta - \tan \theta \quad (\text{as } 1 + \tan^2 \theta \equiv \sec^2 \theta \Rightarrow \sec^2 \theta - \tan^2 \theta \equiv 1)$$

(b)  $x + \frac{1}{x} = \sec \theta + \tan \theta + \sec \theta - \tan \theta = 2 \sec \theta$

$$\Rightarrow \left( x + \frac{1}{x} \right)^2 = 4 \sec^2 \theta$$

$$\Rightarrow x^2 + 2x \times \frac{1}{x} + \frac{1}{x^2} = 4 \sec^2 \theta$$

$$\Rightarrow x^2 + \frac{1}{x^2} + 2 = 4 \sec^2 \theta$$



# Solutionbank

## Edexcel AS and A Level Modular Mathematics

### Exercise D, Question 12

#### Question:

Given that  $2 \sec^2 \theta - \tan^2 \theta = p$  show that  $\operatorname{cosec}^2 \theta = \frac{p-1}{p-2}, p \neq 2$ .

#### Solution:

$$2 \sec^2 \theta - \tan^2 \theta = p$$

$$\Rightarrow 2(1 + \tan^2 \theta) - \tan^2 \theta = p$$

$$\Rightarrow 2 + 2 \tan^2 \theta - \tan^2 \theta = p$$

$$\Rightarrow \tan^2 \theta = p - 2$$

$$\Rightarrow \cot^2 \theta = \frac{1}{p-2} \quad \left( \cot \theta = \frac{1}{\tan \theta} \right)$$

$$\operatorname{cosec}^2 \theta = 1 + \cot^2 \theta = 1 + \frac{1}{p-2} = \frac{(p-2) + 1}{p-2} = \frac{p-1}{p-2}$$

# Solutionbank

## Edexcel AS and A Level Modular Mathematics

### Exercise E, Question 1

#### Question:

Without using a calculator, work out, giving your answer in terms of  $\pi$ , the value of:

(a)  $\arccos 0$

(b)  $\arcsin(1)$

(c)  $\arctan (-1)$

(d)  $\arcsin \left( -\frac{1}{2} \right)$

(e)  $\arccos \left( -\frac{1}{\sqrt{2}} \right)$

(f)  $\arctan \left( -\frac{1}{\sqrt{3}} \right)$

(g)  $\arcsin \left( \sin \frac{\pi}{3} \right)$

(h)  $\arcsin \left( \sin \frac{2\pi}{3} \right)$

#### Solution:

(a)  $\arccos 0$  is the angle  $\alpha$  in  $0 \leq \alpha \leq \pi$  for which  $\cos \alpha = 0$

Refer to graph of  $y = \cos \theta \Rightarrow \alpha = \frac{\pi}{2}$

So  $\arccos 0 = \frac{\pi}{2}$

(b)  $\arcsin 1$  is the angle  $\alpha$  in  $-\frac{\pi}{2} \leq \alpha \leq \frac{\pi}{2}$  for which  $\sin \alpha = 1$

Refer to graph of  $y = \sin \theta \Rightarrow \alpha = \frac{\pi}{2}$

So  $\arcsin 1 = \frac{\pi}{2}$

(c)  $\arctan(-1)$  is the angle  $\alpha$  in  $-\frac{\pi}{2} < \alpha < \frac{\pi}{2}$  for which  $\tan \alpha = -1$

So  $\arctan(-1) = -\frac{\pi}{4}$

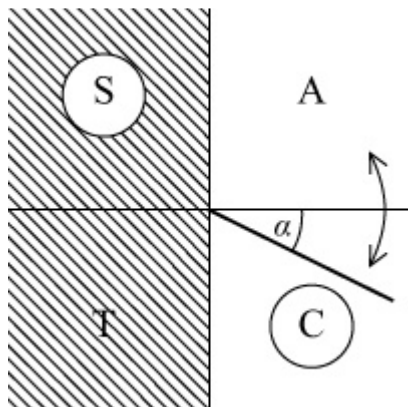

(d)  $\arcsin\left(-\frac{1}{2}\right)$  is the angle  $\alpha$  in  $-\frac{\pi}{2} \leq \alpha \leq \frac{\pi}{2}$  for which

$\sin \alpha = -\frac{1}{2}$

So  $\arcsin\left(-\frac{1}{2}\right) = -\frac{\pi}{6}$

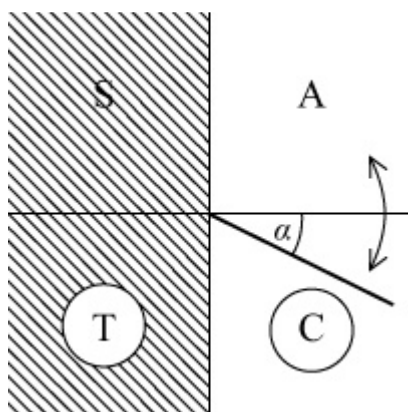

(e)  $\arccos\left(-\frac{1}{\sqrt{2}}\right)$  is the angle  $\alpha$  in  $0 \leq \alpha \leq \pi$  for which  $\cos \alpha = -\frac{1}{\sqrt{2}}$

So  $\arccos\left(-\frac{1}{\sqrt{2}}\right) = \frac{3\pi}{4}$

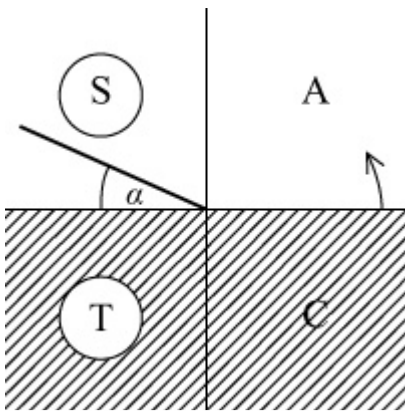

(f)  $\arctan \left( -\frac{1}{\sqrt{3}} \right)$  is the angle  $\alpha$  in  $-\frac{\pi}{2} < \alpha < \frac{\pi}{2}$  for which  $\tan \alpha = -\frac{1}{\sqrt{3}}$

So  $\arctan \left( -\frac{1}{\sqrt{3}} \right) = -\frac{\pi}{6}$

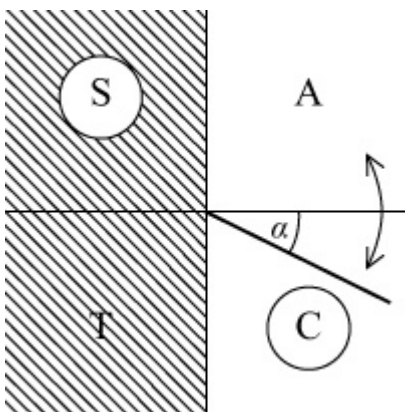

(g)  $\arcsin \left( \sin \frac{\pi}{3} \right)$  is the angle  $\alpha$  in  $-\frac{\pi}{2} \leq \alpha \leq \frac{\pi}{2}$  for which

$$\sin \alpha = \sin \frac{\pi}{3}$$

So  $\arcsin \left( \sin \frac{\pi}{3} \right) = \frac{\pi}{3}$

(h)  $\arcsin \left( \sin \frac{2\pi}{3} \right)$  is the angle  $\alpha$  in  $-\frac{\pi}{2} \leq \alpha \leq \frac{\pi}{2}$  for which

$$\sin \alpha = \sin \frac{2\pi}{3}$$

So  $\arcsin \left( \sin \frac{2\pi}{3} \right) = \frac{\pi}{3}$

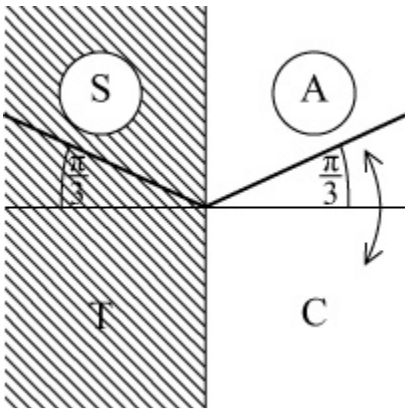

© Pearson Education Ltd 2008

# Solutionbank

## Edexcel AS and A Level Modular Mathematics

### Exercise E, Question 2

#### Question:

Find the value of:

(a)  $\arcsin \left( \frac{1}{2} \right) + \arcsin \left( -\frac{1}{2} \right)$

(b)  $\arccos \left( \frac{1}{2} \right) - \arccos \left( -\frac{1}{2} \right)$

(c)  $\arctan ( 1 ) - \arctan ( - 1 )$

#### Solution:

(a)  $\arcsin \left( \frac{1}{2} \right) + \arcsin \left( -\frac{1}{2} \right) = \frac{\pi}{6} + \left( -\frac{\pi}{6} \right) = 0$

(b)  $\arccos \left( \frac{1}{2} \right) - \arccos \left( -\frac{1}{2} \right) = \frac{\pi}{3} - \frac{2\pi}{3} = -\frac{\pi}{3}$

(c)  $\arctan ( 1 ) - \arctan ( - 1 ) = \frac{\pi}{4} - \left( -\frac{\pi}{4} \right) = \frac{\pi}{2}$

# Solutionbank

## Edexcel AS and A Level Modular Mathematics

### Exercise E, Question 3

#### Question:

Without using a calculator, work out the values of:

(a)  $\sin \left( \arcsin \frac{1}{2} \right)$

(b)  $\sin \left[ \arcsin \left( -\frac{1}{2} \right) \right]$

(c)  $\tan [ \arctan ( -1 ) ]$

(d)  $\cos(\arccos 0)$

#### Solution:

(a)  $\sin \left( \arcsin \frac{1}{2} \right)$

$$\arcsin \frac{1}{2} = \alpha \text{ where } \sin \alpha = \frac{1}{2}, -\frac{\pi}{2} \leq \alpha \leq \frac{\pi}{2}$$

$$\text{So } \arcsin \frac{1}{2} = \frac{\pi}{6}$$

$$\Rightarrow \sin \left( \arcsin \frac{1}{2} \right) = \sin \frac{\pi}{6} = \frac{1}{2}$$

(b)  $\sin \left[ \arcsin \left( -\frac{1}{2} \right) \right]$

$$\arcsin \left( -\frac{1}{2} \right) = \alpha \text{ where } \sin \alpha = -\frac{1}{2}, -\frac{\pi}{2} \leq \alpha \leq \frac{\pi}{2}$$

$$\text{So } \arcsin \left( -\frac{1}{2} \right) = -\frac{\pi}{6}$$

$$\Rightarrow \sin \left[ \arcsin \left( -\frac{1}{2} \right) \right] = \sin \left( -\frac{\pi}{6} \right) = -\frac{1}{2}$$

(c)  $\tan [ \arctan ( -1 ) ]$

$$\arctan ( -1 ) = \alpha \text{ where } \tan \alpha = -1, -\frac{\pi}{2} < \alpha < \frac{\pi}{2}$$

$$\text{So } \arctan(-1) = -\frac{\pi}{4}$$

$$\Rightarrow \tan[\arctan(-1)] = \tan\left(-\frac{\pi}{4}\right) = -1$$

(d)  $\cos(\arccos 0)$

$$\arccos 0 = \alpha \text{ where } \cos \alpha = 0, 0 \leq \alpha \leq \pi$$

$$\text{So } \arccos 0 = \frac{\pi}{2}$$

$$\Rightarrow \cos(\arccos 0) = \cos \frac{\pi}{2} = 0$$



# Solutionbank

## Edexcel AS and A Level Modular Mathematics

### Exercise E, Question 4

#### Question:

Without using a calculator, work out the exact values of:

$$(a) \sin \left[ \arccos \left( \frac{1}{2} \right) \right]$$

$$(b) \cos \left[ \arcsin \left( -\frac{1}{2} \right) \right]$$

$$(c) \tan \left[ \arccos \left( -\frac{\sqrt{2}}{2} \right) \right]$$

$$(d) \sec \left[ \arctan \left( \sqrt{3} \right) \right]$$

$$(e) \operatorname{cosec} \left[ \arcsin \left( -1 \right) \right]$$

$$(f) \sin \left[ 2 \arcsin \left( \frac{\sqrt{2}}{2} \right) \right]$$

#### Solution:

$$(a) \sin \left( \arccos \frac{1}{2} \right)$$

$$\arccos \frac{1}{2} = \frac{\pi}{3}$$

$$\sin \frac{\pi}{3} = \frac{\sqrt{3}}{2}$$

$$(b) \cos \left[ \arcsin \left( -\frac{1}{2} \right) \right]$$

$$\arcsin \left( -\frac{1}{2} \right) = -\frac{\pi}{6}$$

$$\cos \left( -\frac{\pi}{6} \right) = +\frac{\sqrt{3}}{2}$$

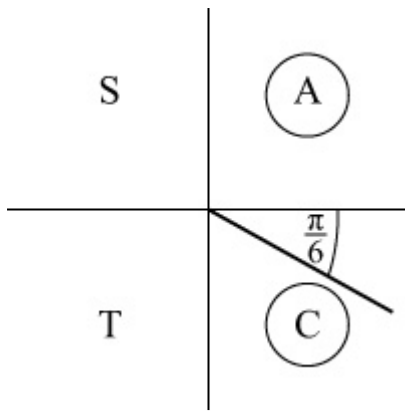

$$(c) \tan \left[ \arccos \left( -\frac{\sqrt{2}}{2} \right) \right]$$

$$\arccos \left( -\frac{\sqrt{2}}{2} \right) = \alpha \text{ where } \cos \alpha = -\frac{\sqrt{2}}{2}, 0 \leq \alpha \leq \pi$$

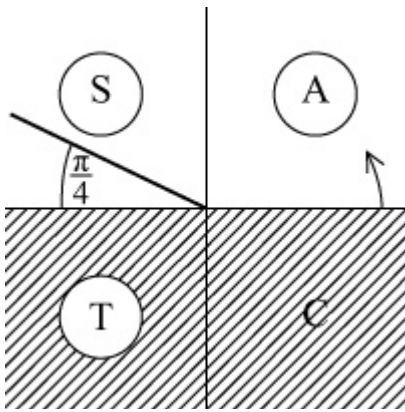

$$\text{So } \arccos \left( -\frac{\sqrt{2}}{2} \right) = \frac{3\pi}{4}$$

$$\tan \frac{3\pi}{4} = -1$$

$$(d) \sec (\arctan \sqrt{3})$$

$$\arctan \sqrt{3} = \frac{\pi}{3} \quad (\text{the angle whose tan is } \sqrt{3})$$

$$\sec \frac{\pi}{3} = \frac{1}{\cos \frac{\pi}{3}} = \frac{1}{\frac{1}{2}} = 2$$

$$(e) \operatorname{cosec} [\arcsin (-1)]$$

$$\arcsin (-1) = \alpha \text{ where } \sin \alpha = -1, -\frac{\pi}{2} \leq \alpha \leq \frac{\pi}{2}$$

$$\text{So } \arcsin(-1) = -\frac{\pi}{2}$$

$$\Rightarrow \operatorname{cosec}[\arcsin(-1)] = \frac{1}{\sin(-\frac{\pi}{2})} = \frac{1}{-1} = -1$$

$$\text{(f) } \sin\left[2 \arcsin\left(\frac{\sqrt{2}}{2}\right)\right]$$

$$\arcsin\frac{\sqrt{2}}{2} = \frac{\pi}{4}$$

$$\text{So } \sin\left[2 \arcsin\left(\frac{\sqrt{2}}{2}\right)\right] = \sin\frac{\pi}{2} = 1$$

# Solutionbank

## Edexcel AS and A Level Modular Mathematics

Exercise E, Question 5

### Question:

Given that  $\arcsin k = \alpha$ , where  $0 < k < 1$  and  $\alpha$  is in radians, write down, in terms of  $\alpha$ , the first two positive values of  $x$  satisfying the equation  $\sin x = k$ .

### Solution:

As  $k$  is positive, the first two positive solutions of  $\sin x = k$  are  $\arcsin k$  and  $\pi - \arcsin k$

i.e.  $\alpha$  and  $\pi - \alpha$

(Try a few examples, taking specific values for  $k$ ).

© Pearson Education Ltd 2008

# Solutionbank

## Edexcel AS and A Level Modular Mathematics

### Exercise E, Question 6

#### Question:

Given that  $x$  satisfies  $\arcsin x = k$ , where  $0 < k < \frac{\pi}{2}$ ,

(a) state the range of possible values of  $x$

(b) express, in terms of  $x$ ,  
 (i)  $\cos k$       (ii)  $\tan k$

Given, instead, that  $-\frac{\pi}{2} < k < 0$ ,

(c) how, if at all, would it affect your answers to (b)?

#### Solution:

(a)  $\arcsin x$  is the angle  $\alpha$  in  $-\frac{\pi}{2} \leq \alpha \leq \frac{\pi}{2}$  such that  $\sin \alpha = x$

In this case  $x = \sin k$  where  $0 < k < \frac{\pi}{2}$

As  $\sin$  is an increasing function

$$\sin 0 < x < \sin \frac{\pi}{2}$$

i.e.  $0 < x < 1$

$$(b) (i) \cos k = \pm \sqrt{1 - \sin^2 k} = \pm \sqrt{1 - x^2}$$

$k$  is in the 1st quadrant  $\Rightarrow \cos k > 0$

$$\text{So } \cos k = \sqrt{1 - x^2}$$

$$(ii) \tan k = \frac{\sin k}{\cos k} = \frac{x}{\sqrt{1 - x^2}}$$

(c)  $k$  is now in the 4th quadrant, where  $\cos k$  is positive.

So the value of  $\cos k$  remains the same and there is no change to  $\tan k$ .

# Solutionbank

## Edexcel AS and A Level Modular Mathematics

Exercise E, Question 7

### Question:

The function  $f$  is defined as  $f : x \rightarrow \arcsin x$ ,  $-1 \leq x \leq 1$ , and the function  $g$  is such that  $g(x) = f(2x)$ .

- Sketch the graph of  $y = f(x)$  and state the range of  $f$ .
- Sketch the graph of  $y = g(x)$ .
- Define  $g$  in the form  $g : x \rightarrow \dots$  and give the domain of  $g$ .
- Define  $g^{-1}$  in the form  $g^{-1} : x \rightarrow \dots$

### Solution:

- (a)  $y = \arcsin x$

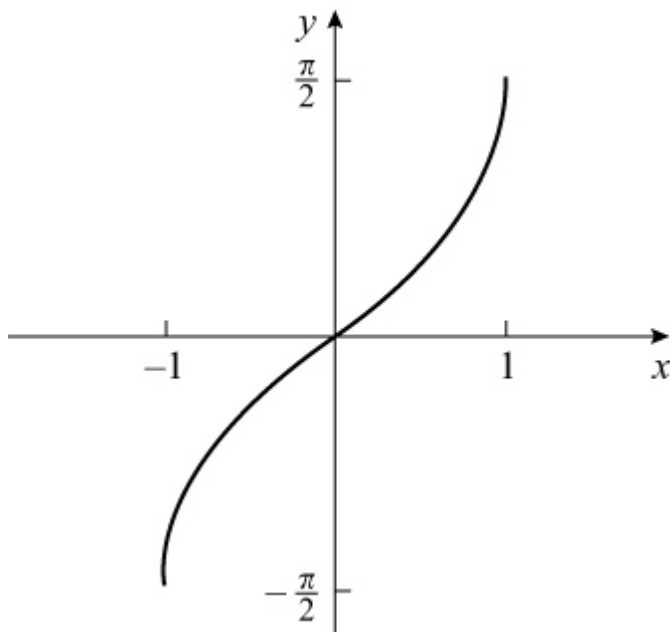

$$\text{Range: } -\frac{\pi}{2} \leq f(x) \leq \frac{\pi}{2}$$

- (b) Using the transformation work, the graph of  $y = f(2x)$  is the graph of  $y = f(x)$  stretched in the  $x$  direction by scale factor  $\frac{1}{2}$ .

$$y = g(x)$$

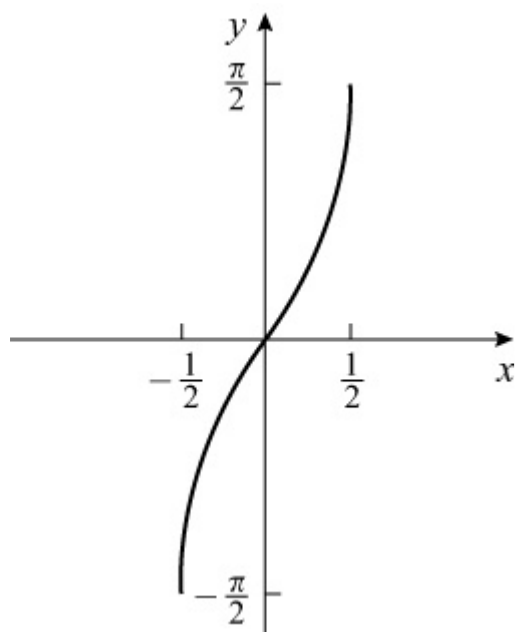

(c)  $g : x \rightarrow \arcsin 2x, \quad -\frac{1}{2} \leq x \leq \frac{1}{2}$

(d) Let  $y = \arcsin 2x$

$$\Rightarrow 2x = \sin y$$

$$\Rightarrow x = \frac{1}{2} \sin y$$

So  $g^{-1} : x \rightarrow \frac{1}{2} \sin x, \quad -\frac{\pi}{2} \leq x \leq \frac{\pi}{2}$

# Solutionbank

## Edexcel AS and A Level Modular Mathematics

Exercise E, Question 8

### Question:

(a) Sketch the graph of  $y = \sec x$ , with the restricted domain

$$0 \leq x \leq \pi, \quad x \neq \frac{\pi}{2}.$$

(b) Given that  $\operatorname{arcsec} x$  is the inverse function of  $\sec x$ ,  $0 \leq x \leq \pi$ ,  $x \neq \frac{\pi}{2}$ , sketch the graph of  $y = \operatorname{arcsec} x$  and state the range of  $\operatorname{arcsec} x$ .

### Solution:

(a)  $y = \sec x$

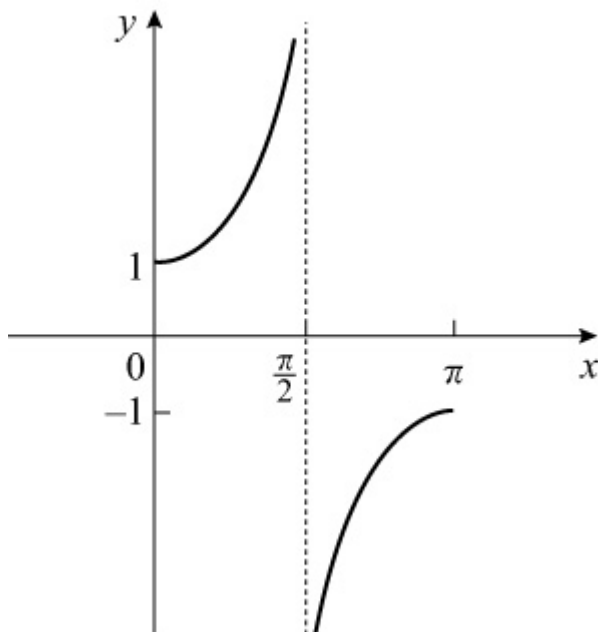

(b) Reflect the above graph in the line  $y = x$   
 $y = \operatorname{arcsec} x$ ,  $x \leq -1$ ,  $x \geq 1$



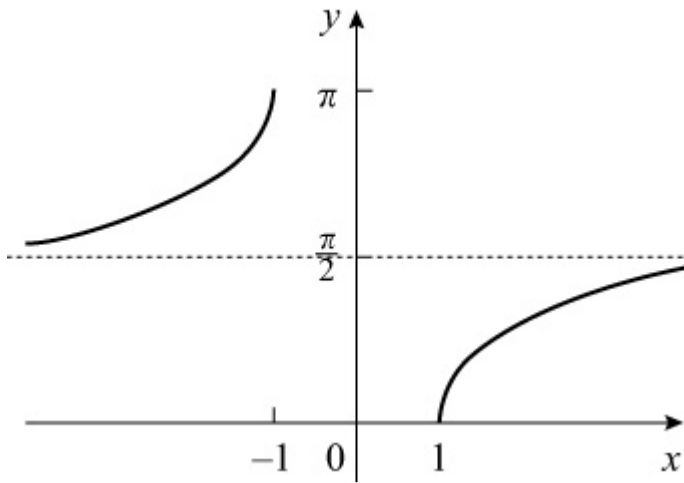

Range:  $0 \leq \text{arcsec } x \leq \pi$ ,  $\text{arcsec } x \neq \frac{\pi}{2}$

© Pearson Education Ltd 2008

# Solutionbank

## Edexcel AS and A Level Modular Mathematics

### Exercise F, Question 1

#### Question:

Solve  $\tan x = 2 \cot x$ , in the interval  $-180^\circ \leq x \leq 90^\circ$ . Give any non-exact answers to 1 decimal place.

#### Solution:

$$\tan x = 2 \cot x, \quad -180^\circ \leq x \leq 90^\circ$$

$$\Rightarrow \tan x = \frac{2}{\tan x}$$

$$\Rightarrow \tan^2 x = 2$$

$$\Rightarrow \tan x = \pm \sqrt{2}$$

Calculator value for  $\tan x = +\sqrt{2}$  is  $54.7^\circ$

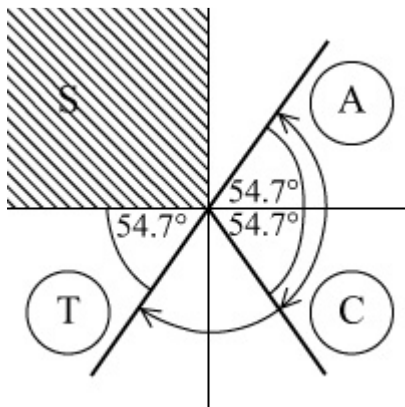

Solutions are required in the 1st, 3rd and 4th quadrants.

Solution set:  $-125.3^\circ, -54.7^\circ, +54.7^\circ$

# Solutionbank

## Edexcel AS and A Level Modular Mathematics

### Exercise F, Question 2

#### Question:

Given that  $p = 2 \sec \theta$  and  $q = 4 \cos \theta$ , express  $p$  in terms of  $q$ .

#### Solution:

$$p = 2 \sec \theta \Rightarrow \sec \theta = \frac{p}{2}$$

$$q = 4 \cos \theta \Rightarrow \cos \theta = \frac{q}{4}$$

$$\sec \theta = \frac{1}{\cos \theta} \Rightarrow \frac{p}{2} = \frac{1}{\frac{q}{4}} \Rightarrow p = \frac{8}{q}$$

# Solutionbank

## Edexcel AS and A Level Modular Mathematics

### Exercise F, Question 3

#### Question:

Given that  $p = \sin \theta$  and  $q = 4 \cot \theta$ , show that  $p^2 q^2 = 16 (1 - p^2)$ .

#### Solution:

$$p = \sin \theta \quad \Rightarrow \quad \frac{1}{p} = \frac{1}{\sin \theta} = \operatorname{cosec} \theta$$

$$q = 4 \cot \theta \quad \Rightarrow \quad \cot \theta = \frac{q}{4}$$

Using  $1 + \cot^2 \theta \equiv \operatorname{cosec}^2 \theta$

$$\Rightarrow 1 + \frac{q^2}{16} = \frac{1}{p^2} \quad (\text{multiply by } 16p^2)$$

$$\Rightarrow 16p^2 + p^2 q^2 = 16$$

$$\Rightarrow p^2 q^2 = 16 - 16p^2 = 16 (1 - p^2)$$

# Solutionbank

## Edexcel AS and A Level Modular Mathematics

### Exercise F, Question 4

#### Question:

Give any non-exact answers to 1 decimal place.

(a) Solve, in the interval  $0 < \theta < 180^\circ$ ,

(i)  $\operatorname{cosec} \theta = 2 \cot \theta$

(ii)  $2 \cot^2 \theta = 7 \operatorname{cosec} \theta - 8$

(b) Solve, in the interval  $0 \leq \theta \leq 360^\circ$ ,

(i)  $\sec(2\theta - 15^\circ) = \operatorname{cosec} 135^\circ$

(ii)  $\sec^2 \theta + \tan \theta = 3$

(c) Solve, in the interval  $0 \leq x \leq 2\pi$ ,

(i)  $\operatorname{cosec} \left( x + \frac{\pi}{15} \right) = -\sqrt{2}$

(ii)  $\sec^2 x = \frac{4}{3}$

#### Solution:

(a) (i)  $\operatorname{cosec} \theta = 2 \cot \theta, 0 < \theta < 180^\circ$

$$\Rightarrow \frac{1}{\sin \theta} = \frac{2 \cos \theta}{\sin \theta}$$

$$\Rightarrow 2 \cos \theta = 1$$

$$\Rightarrow \cos \theta = \frac{1}{2}$$

$$\Rightarrow \theta = 60^\circ$$

(ii)  $2 \cot^2 \theta = 7 \operatorname{cosec} \theta - 8, 0 < \theta < 180^\circ$

$$\Rightarrow 2(\operatorname{cosec}^2 \theta - 1) = 7 \operatorname{cosec} \theta - 8$$

$$\Rightarrow 2 \operatorname{cosec}^2 \theta - 7 \operatorname{cosec} \theta + 6 = 0$$

$$\Rightarrow (2 \operatorname{cosec} \theta - 3)(\operatorname{cosec} \theta - 2) = 0$$

$$\Rightarrow \operatorname{cosec} \theta = \frac{3}{2} \text{ or } \operatorname{cosec} \theta = 2$$

$$\text{So } \sin \theta = \frac{2}{3} \text{ or } \sin \theta = \frac{1}{2}$$

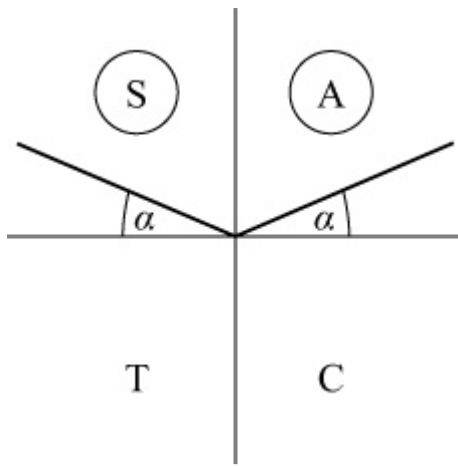

Solutions are  $\alpha^\circ$  and  $(180 - \alpha)^\circ$  where  $\alpha$  is the calculator value.

Solutions set:  $41.8^\circ, 138.2^\circ, 30^\circ, 150^\circ$

i.e.  $30^\circ, 41.8^\circ, 138.2^\circ, 150^\circ$

$$(b) (i) \sec(2\theta - 15^\circ) = \operatorname{cosec} 135^\circ, 0 \leq \theta \leq 360^\circ$$

$$\Rightarrow \cos(2\theta - 15^\circ) = \frac{1}{\operatorname{cosec} 135^\circ} = \sin 135^\circ = \frac{\sqrt{2}}{2}$$

$$\text{Solve } \cos(2\theta - 15^\circ) = \frac{\sqrt{2}}{2}, -15^\circ \leq 2\theta - 15^\circ \leq 705^\circ$$

$$\text{The calculator value is } \cos^{-1}\left(\frac{\sqrt{2}}{2}\right) = 45^\circ$$

cos is positive, so  $(2\theta - 15^\circ)$  is in the 1st and 4th quadrants.

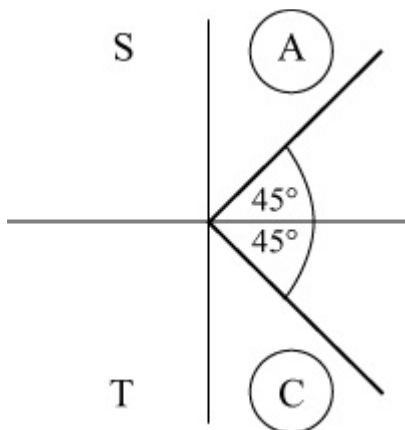

$$\text{So } (2\theta - 15^\circ) = 45^\circ, 315^\circ, 405^\circ, 675^\circ$$

$$\Rightarrow 2\theta = 60^\circ, 330^\circ, 420^\circ, 690^\circ$$

$$\Rightarrow \theta = 30^\circ, 165^\circ, 210^\circ, 345^\circ$$

$$(ii) \sec^2 \theta + \tan \theta = 3, 0 \leq \theta \leq 360^\circ$$

$$\Rightarrow 1 + \tan^2 \theta + \tan \theta = 3$$

$$\Rightarrow \tan^2 \theta + \tan \theta - 2 = 0$$

$$\Rightarrow (\tan \theta - 1)(\tan \theta + 2) = 0$$

$$\Rightarrow \tan \theta = 1 \text{ or } \tan \theta = -2$$

$$\tan \theta = 1 \Rightarrow \theta = 45^\circ, 180^\circ + 45^\circ, \text{ i.e. } 45^\circ, 225^\circ$$

$$\tan \theta = -2 \Rightarrow \theta = 180^\circ + (-63.4)^\circ, 360^\circ + (-63.4)^\circ, \text{ i.e. } 116.6^\circ, 296.6^\circ$$

$$(c) (i) \operatorname{cosec} \left( x + \frac{\pi}{15} \right) = -\sqrt{2}, 0 \leq x \leq 2\pi$$

$$\Rightarrow \sin \left( x + \frac{\pi}{15} \right) = -\frac{1}{\sqrt{2}}$$

$$\text{Calculator value is } \sin^{-1} \left( -\frac{1}{\sqrt{2}} \right) = -\frac{\pi}{4}$$

$\sin \left( x + \frac{\pi}{15} \right)$  is negative, so  $x + \frac{\pi}{15}$  is in 3rd and 4th quadrants.

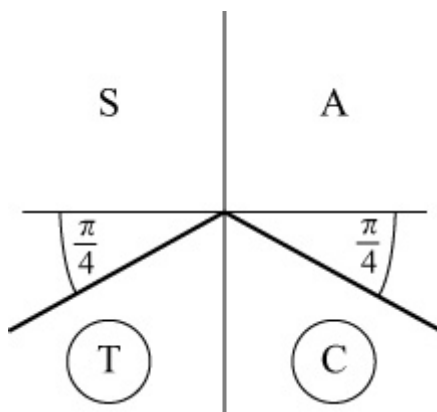

$$\text{So } x + \frac{\pi}{15} = \frac{5\pi}{4}, \frac{7\pi}{4}$$

$$\Rightarrow x = \frac{5\pi}{4} - \frac{\pi}{15}, \frac{7\pi}{4} - \frac{\pi}{15} = \frac{75\pi - 4\pi}{60}, \frac{105\pi - 4\pi}{60} = \frac{71\pi}{60}, \frac{101\pi}{60}$$

$$(ii) \sec^2 x = \frac{4}{3}, 0 \leq x \leq 2\pi$$

$$\Rightarrow \cos^2 x = \frac{3}{4}$$

$$\Rightarrow \cos x = \pm \frac{\sqrt{3}}{2}$$

Calculator value for  $\cos x = +\frac{\sqrt{3}}{2}$  is  $\frac{\pi}{6}$

As  $\cos x$  is  $\pm$ ,  $x$  is in all four quadrants.

Solutions set:  $x = \frac{\pi}{6}, \pi - \frac{\pi}{6}, \pi + \frac{\pi}{6}, 2\pi - \frac{\pi}{6} = \frac{\pi}{6}, \frac{5\pi}{6}, \frac{7\pi}{6}, \frac{11\pi}{6}$

© Pearson Education Ltd 2008



# Solutionbank

## Edexcel AS and A Level Modular Mathematics

### Exercise F, Question 5

#### Question:

Given that  $5 \sin x \cos y + 4 \cos x \sin y = 0$ , and that  $\cot x = 2$ , find the value of  $\cot y$ .

#### Solution:

$$5 \sin x \cos y + 4 \cos x \sin y = 0$$

$$\Rightarrow \frac{5 \sin x \cos y}{\sin x \sin y} + \frac{4 \cos x \sin y}{\sin x \sin y} = 0 \quad (\text{divide by } \sin x \sin y)$$

$$\Rightarrow \frac{5 \cos y}{\sin y} + \frac{4 \cos x}{\sin x} = 0$$

$$\text{So } 5 \cot y + 4 \cot x = 0$$

$$\text{As } \cot x = 2$$

$$5 \cot y + 8 = 0$$

$$5 \cot y = -8$$

$$\cot y = -\frac{8}{5}$$

# Solutionbank

## Edexcel AS and A Level Modular Mathematics

### Exercise F, Question 6

#### Question:

Show that:

$$(a) (\tan \theta + \cot \theta) (\sin \theta + \cos \theta) \equiv \sec \theta + \operatorname{cosec} \theta$$

$$(b) \frac{\operatorname{cosec} x}{\operatorname{cosec} x - \sin x} \equiv \sec^2 x$$

$$(c) (1 - \sin x) (1 + \operatorname{cosec} x) \equiv \cos x \cot x$$

$$(d) \frac{\cot x}{\operatorname{cosec} x - 1} - \frac{\cos x}{1 + \sin x} \equiv 2 \tan x$$

$$(e) \frac{1}{\operatorname{cosec} \theta - 1} + \frac{1}{\operatorname{cosec} \theta + 1} \equiv 2 \sec \theta \tan \theta$$

$$(f) \frac{(\sec \theta - \tan \theta) (\sec \theta + \tan \theta)}{1 + \tan^2 \theta} \equiv \cos^2 \theta$$

#### Solution:

$$\begin{aligned} (a) \text{ L.H.S.} &\equiv (\tan \theta + \cot \theta) (\sin \theta + \cos \theta) \\ &\equiv \left( \frac{\sin \theta}{\cos \theta} + \frac{\cos \theta}{\sin \theta} \right) (\sin \theta + \cos \theta) \\ &\equiv \left( \frac{\sin^2 \theta + \cos^2 \theta}{\cos \theta \sin \theta} \right) (\sin \theta + \cos \theta) \\ &\equiv \left( \frac{1}{\cos \theta \sin \theta} \right) (\sin \theta + \cos \theta) \\ &\equiv \frac{\sin \theta}{\cos \theta \sin \theta} + \frac{\cos \theta}{\cos \theta \sin \theta} \\ &\equiv \frac{1}{\cos \theta} + \frac{1}{\sin \theta} \\ &\equiv \sec \theta + \operatorname{cosec} \theta \equiv \text{R.H.S.} \end{aligned}$$

(b)

$$\begin{aligned}
\text{L.H.S.} &\equiv \frac{\operatorname{cosec} x}{\operatorname{cosec} x - \sin x} \\
&\equiv \frac{\frac{1}{\sin x}}{\frac{1}{\sin x} - \sin x} \\
&\equiv \frac{\frac{1}{\sin x}}{\frac{1 - \sin^2 x}{\sin x}} \\
&\equiv \frac{1}{\sin x} \times \frac{\sin x}{1 - \sin^2 x} \\
&\equiv \frac{1}{1 - \sin^2 x} \\
&\equiv \frac{1}{\cos^2 x} \quad (\text{using } \sin^2 x + \cos^2 x \equiv 1) \\
&\equiv \sec^2 x \equiv \text{R.H.S.}
\end{aligned}$$

$$\begin{aligned}
\text{(c) L.H.S.} &\equiv (1 - \sin x)(1 + \operatorname{cosec} x) \\
&\equiv 1 - \sin x + \operatorname{cosec} x - \sin x \operatorname{cosec} x \\
&\equiv 1 - \sin x + \operatorname{cosec} x - 1 \quad \left( \text{as } \operatorname{cosec} x = \frac{1}{\sin x} \right) \\
&\equiv \operatorname{cosec} x - \sin x \\
&\equiv \frac{1}{\sin x} - \sin x \\
&\equiv \frac{1 - \sin^2 x}{\sin x} \\
&\equiv \frac{\cos^2 x}{\sin x} \\
&\equiv \frac{\cos x}{\sin x} \times \cos x \\
&\equiv \cos x \cot x \equiv \text{R.H.S.}
\end{aligned}$$

(d)

$$\begin{aligned}
\text{L.H.S.} &\equiv \frac{\cot x}{\operatorname{cosec} x - 1} - \frac{\cos x}{1 + \sin x} \\
&\equiv \frac{\frac{\cos x}{\sin x}}{\frac{1}{\sin x} - 1} - \frac{\cos x}{1 + \sin x} \\
&\equiv \frac{\frac{\cos x}{\sin x}}{\frac{1 - \sin x}{\sin x}} - \frac{\cos x}{1 + \sin x} \\
&\equiv \frac{\cos x}{1 - \sin x} - \frac{\cos x}{1 + \sin x} \\
&\equiv \frac{\cos x(1 + \sin x) - \cos x(1 - \sin x)}{(1 - \sin x)(1 + \sin x)} \\
&\equiv \frac{2 \cos x \sin x}{1 - \sin^2 x} \\
&\equiv \frac{2 \cos x \sin x}{\cos^2 x} \\
&\equiv 2 \frac{\sin x}{\cos x} \\
&\equiv 2 \tan x \equiv \text{R.H.S.}
\end{aligned}$$

$$\begin{aligned}
\text{(e) L.H.S.} &\equiv \frac{1}{\operatorname{cosec} \theta - 1} + \frac{1}{\operatorname{cosec} \theta + 1} \\
&\equiv \frac{(\operatorname{cosec} \theta + 1) + (\operatorname{cosec} \theta - 1)}{(\operatorname{cosec} \theta - 1)(\operatorname{cosec} \theta + 1)} \\
&\equiv \frac{2 \operatorname{cosec} \theta}{\operatorname{cosec}^2 \theta - 1} \\
&\equiv \frac{2 \operatorname{cosec} \theta}{\cot^2 \theta} \quad (1 + \cot^2 \theta \equiv \operatorname{cosec}^2 \theta) \\
&\equiv \frac{2}{\sin \theta} \times \frac{\sin^2 \theta}{\cos^2 \theta} \\
&\equiv 2 \times \frac{1}{\cos \theta} \times \frac{\sin \theta}{\cos \theta} \\
&\equiv 2 \sec \theta \tan \theta \equiv \text{R.H.S.}
\end{aligned}$$

$$\begin{aligned}
\text{(f) L.H.S.} &\equiv \frac{(\sec \theta - \tan \theta)(\sec \theta + \tan \theta)}{1 + \tan^2 \theta} \\
&\equiv \frac{\sec^2 \theta - \tan^2 \theta}{\sec^2 \theta} \\
&\equiv \frac{(1 + \tan^2 \theta) - \tan^2 \theta}{\sec^2 \theta} \\
&\equiv \frac{1}{\sec^2 \theta} \\
&\equiv \cos^2 \theta \equiv \text{R.H.S.}
\end{aligned}$$



# Solutionbank

## Edexcel AS and A Level Modular Mathematics

### Exercise F, Question 7

#### Question:

(a) Show that  $\frac{\sin x}{1 + \cos x} + \frac{1 + \cos x}{\sin x} \equiv 2 \operatorname{cosec} x$ .

(b) Hence solve, in the interval  $-2\pi \leq x \leq 2\pi$ ,  $\frac{\sin x}{1 + \cos x} +$

$$\frac{1 + \cos x}{\sin x} = -\frac{4}{\sqrt{3}}.$$

#### Solution:

(a) L.H.S.  $\equiv \frac{\sin x}{1 + \cos x} + \frac{1 + \cos x}{\sin x}$

$$\equiv \frac{\sin^2 x + (1 + \cos x)^2}{(1 + \cos x) \sin x}$$

$$\equiv \frac{\sin^2 x + 1 + 2 \cos x + \cos^2 x}{(1 + \cos x) \sin x}$$

$$\equiv \frac{2 + 2 \cos x}{(1 + \cos x) \sin x} \quad \left( \sin^2 x + \cos^2 x \equiv 1 \right)$$

$$\equiv \frac{2(1 + \cos x)}{(1 + \cos x) \sin x}$$

$$\equiv \frac{2}{\sin x}$$

$$\equiv 2 \operatorname{cosec} x \equiv \text{R.H.S.}$$

(b) Solve  $2 \operatorname{cosec} x = -\frac{4}{\sqrt{3}}$ ,  $-2\pi \leq x \leq 2\pi$

$$\Rightarrow \operatorname{cosec} x = -\frac{2}{\sqrt{3}}$$

$$\Rightarrow \sin x = -\frac{\sqrt{3}}{2}$$

Calculator value is  $-\frac{\pi}{3}$

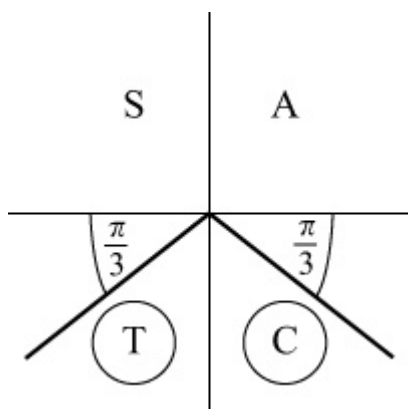

Solutions in  $-2\pi \leq x \leq 2\pi$  are

$$-\frac{\pi}{3}, \quad -\pi + \frac{\pi}{3}, \quad \pi + \frac{\pi}{3}, \quad 2\pi - \frac{\pi}{3},$$

i.e.  $-\frac{\pi}{3}, \quad -\frac{2\pi}{3}, \quad \frac{4\pi}{3}, \quad \frac{5\pi}{3}$

# Solutionbank

## Edexcel AS and A Level Modular Mathematics

### Exercise F, Question 8

#### Question:

Prove that  $\frac{1 + \cos \theta}{1 - \cos \theta} \equiv (\operatorname{cosec} \theta + \cot \theta)^2$ .

#### Solution:

$$\begin{aligned} \text{R.H.S.} &\equiv (\operatorname{cosec} \theta + \cot \theta)^2 \\ &\equiv \left( \frac{1}{\sin \theta} + \frac{\cos \theta}{\sin \theta} \right)^2 \\ &\equiv \frac{(1 + \cos \theta)^2}{\sin^2 \theta} \\ &\equiv \frac{(1 + \cos \theta)^2}{1 - \cos^2 \theta} \\ &\equiv \frac{(1 + \cos \theta)(1 + \cos \theta)}{(1 + \cos \theta)(1 - \cos \theta)} \\ &\equiv \frac{1 + \cos \theta}{1 - \cos \theta} \equiv \text{L.H.S.} \end{aligned}$$



# Solutionbank

## Edexcel AS and A Level Modular Mathematics

### Exercise F, Question 9

#### Question:

Given that  $\sec A = -3$ , where  $\frac{\pi}{2} < A < \pi$ ,

(a) calculate the exact value of  $\tan A$ .

(b) Show that  $\operatorname{cosec} A = \frac{3\sqrt{2}}{4}$ .

#### Solution:

(a)  $\sec A = -3$ ,  $\frac{\pi}{2} < A < \pi$ , i.e.  $A$  is in 2nd quadrant.

$$\text{As } 1 + \tan^2 A = \sec^2 A$$

$$1 + \tan^2 A = 9$$

$$\tan^2 A = 8$$

$$\tan A = \pm \sqrt{8} = \pm 2\sqrt{2}$$

As  $A$  is in 2nd quadrant,  $\tan A$  is -ve.

$$\text{So } \tan A = -2\sqrt{2}$$

(b)  $\sec A = -3$ , so  $\cos A = -\frac{1}{3}$

$$\text{As } \tan A = \frac{\sin A}{\cos A}$$

$$\sin A = \cos A \times \tan A = -\frac{1}{3} \times -2\sqrt{2} = \frac{2\sqrt{2}}{3}$$

$$\text{So } \operatorname{cosec} A = \frac{3}{2\sqrt{2}} = \frac{3\sqrt{2}}{2 \times 2} = \frac{3\sqrt{2}}{4}$$

# Solutionbank

## Edexcel AS and A Level Modular Mathematics

### Exercise F, Question 10

#### Question:

Given that  $\sec \theta = k$ ,  $|k| \geq 1$ , and that  $\theta$  is obtuse, express in terms of  $k$ :

(a)  $\cos \theta$

(b)  $\tan^2 \theta$

(c)  $\cot \theta$

(d)  $\operatorname{cosec} \theta$

#### Solution:

$$\sec \theta = k, |k| \geq 1$$

$\theta$  is in the 2nd quadrant  $\Rightarrow k$  is negative

(a)  $\cos \theta = \frac{1}{\sec \theta} = \frac{1}{k}$

(b) Using  $1 + \tan^2 \theta = \sec^2 \theta$   
 $\tan^2 \theta = k^2 - 1$

(c)  $\tan \theta = \pm \sqrt{k^2 - 1}$

In the 2nd quadrant,  $\tan \theta$  is -ve.

So  $\tan \theta = -\sqrt{k^2 - 1}$

$$\cot \theta = \frac{1}{\tan \theta} = \frac{1}{-\sqrt{k^2 - 1}} = -\frac{1}{\sqrt{k^2 - 1}}$$

(d) Using  $1 + \cot^2 \theta = \operatorname{cosec}^2 \theta$

$$\operatorname{cosec}^2 \theta = 1 + \frac{1}{k^2 - 1} = \frac{k^2 - 1 + 1}{k^2 - 1} = \frac{k^2}{k^2 - 1}$$

So  $\operatorname{cosec} \theta = \pm \frac{k}{\sqrt{k^2 - 1}}$

In the 2nd quadrant,  $\operatorname{cosec} \theta$  is +ve.

As  $k$  is -ve,  $\operatorname{cosec} \theta = \frac{-k}{\sqrt{k^2 - 1}}$

# Solutionbank

## Edexcel AS and A Level Modular Mathematics

### Exercise F, Question 11

#### Question:

Solve, in the interval  $0 \leq x \leq 2\pi$ , the equation  $\sec \left( x + \frac{\pi}{4} \right) = 2$ , giving your answers in terms of  $\pi$ .

#### Solution:

$$\sec \left( x + \frac{\pi}{4} \right) = 2, 0 \leq x \leq 2\pi$$

$$\Rightarrow \cos \left( x + \frac{\pi}{4} \right) = \frac{1}{2}, 0 \leq x \leq 2\pi$$

$$\Rightarrow x + \frac{\pi}{4} = \cos^{-1} \frac{1}{2}, 2\pi - \cos^{-1} \frac{1}{2} = \frac{\pi}{3}, 2\pi - \frac{\pi}{3}$$

$$\text{So } x = \frac{\pi}{3} - \frac{\pi}{4}, \frac{5\pi}{3} - \frac{\pi}{4} = \frac{4\pi - 3\pi}{12}, \frac{20\pi - 3\pi}{12} = \frac{\pi}{12}, \frac{17\pi}{12}$$

# Solutionbank

## Edexcel AS and A Level Modular Mathematics

### Exercise F, Question 12

#### Question:

Find, in terms of  $\pi$ , the value of  $\arcsin \left( \frac{1}{2} \right) - \arcsin \left( -\frac{1}{2} \right)$ .

#### Solution:

$\arcsin \left( \frac{1}{2} \right)$  is the angle in the interval  $-\frac{\pi}{2} \leq \text{angle} \leq \frac{\pi}{2}$  whose sine is  $\frac{1}{2}$ .

$$\text{So } \arcsin \left( \frac{1}{2} \right) = \frac{\pi}{6}$$

$$\text{Similarly, } \arcsin \left( -\frac{1}{2} \right) = -\frac{\pi}{6}$$

$$\text{So } \arcsin \left( \frac{1}{2} \right) - \arcsin \left( -\frac{1}{2} \right) = \frac{\pi}{6} - \left( -\frac{\pi}{6} \right) = \frac{\pi}{3}$$

# Solutionbank

## Edexcel AS and A Level Modular Mathematics

### Exercise F, Question 13

#### Question:

Solve, in the interval  $0 \leq x \leq 2\pi$ , the equation  $\sec^2 x - \frac{2\sqrt{3}}{3}\tan x - 2 = 0$ , giving your answers in terms of  $\pi$ .

#### Solution:

$$\sec^2 x - \frac{2\sqrt{3}}{3}\tan x - 2 = 0, 0 \leq x \leq 2\pi$$

$$\Rightarrow (1 + \tan^2 x) - \frac{2\sqrt{3}}{3}\tan x - 2 = 0$$

$$\tan^2 x - \frac{2\sqrt{3}}{3}\tan x - 1 = 0$$

(This does factorise but you may not have noticed!)

$$\left(\tan x + \frac{\sqrt{3}}{3}\right) (\tan x - \sqrt{3}) = 0$$

$$\Rightarrow \tan x = -\frac{\sqrt{3}}{3} \text{ or } \tan x = \sqrt{3}$$

Calculator values are  $-\frac{\pi}{6}$  and  $\frac{\pi}{3}$ .

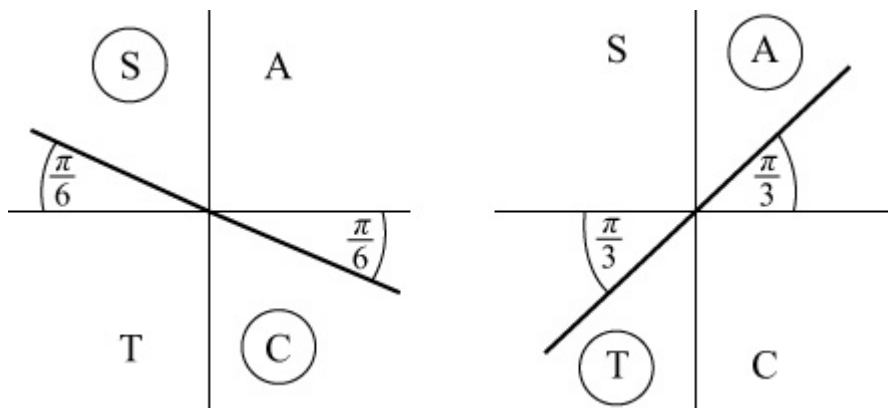

Solution set:  $\frac{\pi}{3}, \frac{5\pi}{6}, \frac{4\pi}{3}, \frac{11\pi}{6}$

# Solutionbank

## Edexcel AS and A Level Modular Mathematics

### Exercise F, Question 14

#### Question:

- (a) Factorise  $\sec x \operatorname{cosec} x - 2 \sec x - \operatorname{cosec} x + 2$ .
- (b) Hence solve  $\sec x \operatorname{cosec} x - 2 \sec x - \operatorname{cosec} x + 2 = 0$ , in the interval  $0 \leq x \leq 360^\circ$ .

#### Solution:

$$\begin{aligned} \text{(a) } \sec x \operatorname{cosec} x - 2 \sec x - \operatorname{cosec} x + 2 & \\ &= \sec x (\operatorname{cosec} x - 2) - (\operatorname{cosec} x - 2) \\ &= (\operatorname{cosec} x - 2) (\sec x - 1) \end{aligned}$$

$$\begin{aligned} \text{(b) So } \sec x \operatorname{cosec} x - 2 \sec x - \operatorname{cosec} x + 2 &= 0 \\ \Rightarrow (\operatorname{cosec} x - 2) (\sec x - 1) &= 0 \\ \Rightarrow \operatorname{cosec} x = 2 \text{ or } \sec x = 1 & \\ \Rightarrow \sin x = \frac{1}{2} \text{ or } \cos x = 1 & \end{aligned}$$

$$\sin x = \frac{1}{2}, \quad 0 \leq x \leq 360^\circ$$

$$\Rightarrow x = 30^\circ, (180 - 30)^\circ$$

$$\cos x = 1, \quad 0 \leq x \leq 360^\circ,$$

$$\Rightarrow x = 0^\circ, 360^\circ \quad (\text{from the graph})$$

Full set of solutions:  $0^\circ, 30^\circ, 150^\circ, 360^\circ$

# Solutionbank

## Edexcel AS and A Level Modular Mathematics

### Exercise F, Question 15

#### Question:

Given that  $\arctan (x - 2) = -\frac{\pi}{3}$ , find the value of  $x$ .

#### Solution:

$$\arctan (x - 2) = -\frac{\pi}{3}$$

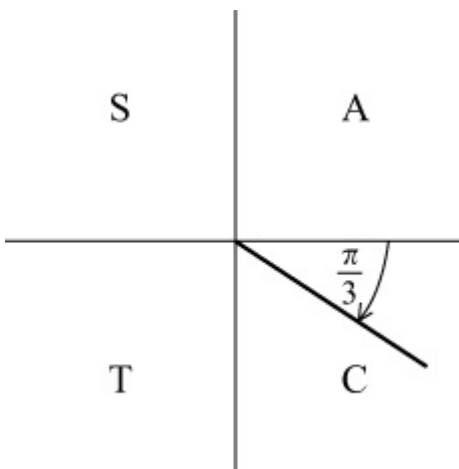

$$\Rightarrow x - 2 = \tan \left( -\frac{\pi}{3} \right)$$

$$\Rightarrow x - 2 = -\sqrt{3}$$

$$\Rightarrow x = 2 - \sqrt{3}$$

# Solutionbank

## Edexcel AS and A Level Modular Mathematics

### Exercise F, Question 16

#### Question:

On the same set of axes sketch the graphs of  $y = \cos x$ ,  $0 \leq x \leq \pi$ , and  $y = \arccos x$ ,  $-1 \leq x \leq 1$ , showing the coordinates of points in which the curves meet the axes.

#### Solution:

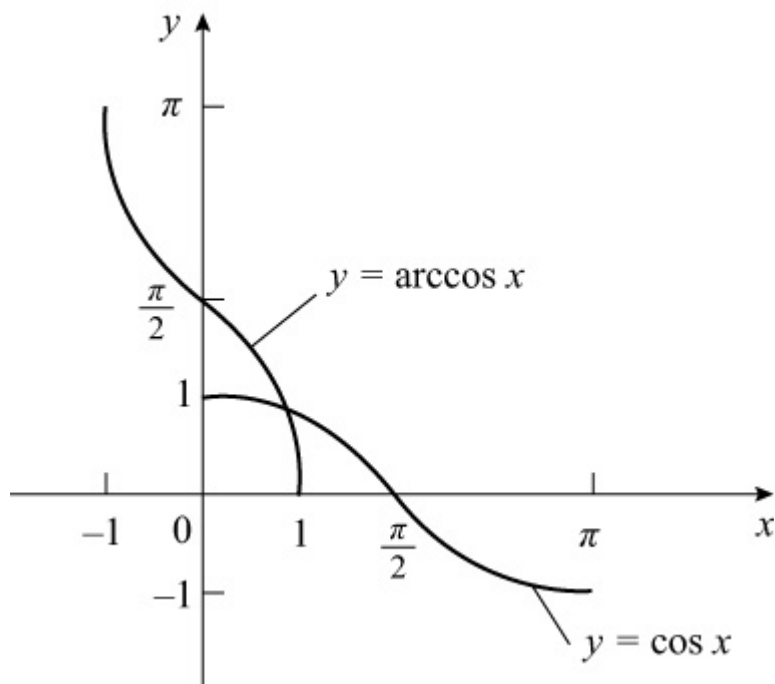

...

© Pearson Education Ltd 2008



# Solutionbank

## Edexcel AS and A Level Modular Mathematics

### Exercise F, Question 17

#### Question:

(a) Given that  $\sec x + \tan x = -3$ , use the identity  $1 + \tan^2 x \equiv \sec^2 x$  to find the value of  $\sec x - \tan x$ .

(b) Deduce the value of

(i)  $\sec x$

(ii)  $\tan x$

(c) Hence solve, in the interval

$-180^\circ \leq x \leq 180^\circ$ ,  $\sec x + \tan x = -3$ . (Give answer to 1 decimal place).

#### Solution:

(a) As  $1 + \tan^2 x \equiv \sec^2 x$

$$\sec^2 x - \tan^2 x \equiv 1$$

$$\Rightarrow (\sec x - \tan x)(\sec x + \tan x) \equiv 1 \quad (\text{difference of two squares})$$

As  $\tan x + \sec x = -3$  is given,

$$\text{so } -3(\sec x - \tan x) = 1$$

$$\Rightarrow \sec x - \tan x = -\frac{1}{3}$$

(b)  $\sec x + \tan x = -3$

$$\text{and } \sec x - \tan x = -\frac{1}{3}$$

$$(i) \text{ Add the equations } \Rightarrow 2 \sec x = -\frac{10}{3} \Rightarrow \sec x = -\frac{5}{3}$$

$$(ii) \text{ Subtract the equation } \Rightarrow 2 \tan x = -3 + \frac{1}{3} = -\frac{8}{3} \Rightarrow \tan x = -\frac{4}{3}$$

(c) As  $\sec x$  and  $\tan x$  are both  $-ve$ ,  $\cos x$  and  $\tan x$  are both  $-ve$ .

So  $x$  must be in the 2nd quadrant.

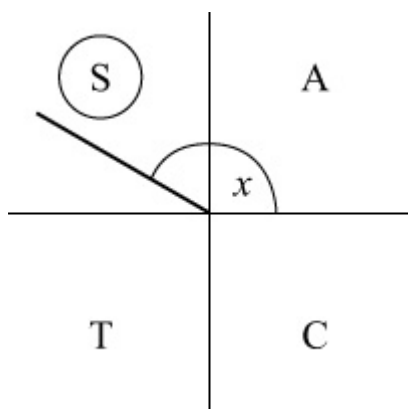

Solving  $\tan x = -\frac{4}{3}$ , where  $x$  is in the 2nd quadrant, gives  $180^\circ + \left( -53.1^\circ \right) = 126.9^\circ$

# Solutionbank

## Edexcel AS and A Level Modular Mathematics

Exercise F, Question 18

### Question:

Given that  $p = \sec \theta - \tan \theta$  and  $q = \sec \theta + \tan \theta$ , show that  $p = \frac{1}{q}$ .

### Solution:

$$p = \sec \theta - \tan \theta, q = \sec \theta + \tan \theta$$

Multiply together:

$$pq = (\sec \theta - \tan \theta) (\sec \theta + \tan \theta) = \sec^2 \theta - \tan^2 \theta = 1 \quad (\text{since } 1 + \tan^2 \theta = \sec^2 \theta)$$

$$\Rightarrow p = \frac{1}{q}$$

(There are several ways of solving this problem).

© Pearson Education Ltd 2008

# Solutionbank

## Edexcel AS and A Level Modular Mathematics

### Exercise F, Question 19

#### Question:

(a) Prove that  $\sec^4 \theta - \tan^4 \theta \equiv \sec^2 \theta + \tan^2 \theta$ .

(b) Hence solve, in the interval

$-180^\circ \leq \theta \leq 180^\circ$ ,  $\sec^4 \theta = \tan^4 \theta + 3 \tan \theta$ . (Give answers to 1 decimal place).

#### Solution:

(a) L.H.S.  $\equiv \sec^4 \theta - \tan^4 \theta$   
 $\equiv (\sec^2 \theta + \tan^2 \theta) (\sec^2 \theta - \tan^2 \theta)$   
 $\equiv (\sec^2 \theta + \tan^2 \theta) (1)$   
 $\equiv \sec^2 \theta + \tan^2 \theta \equiv \text{R.H.S.}$

(b)  $\sec^4 \theta = \tan^4 \theta + 3 \tan \theta$   
 $\Rightarrow \sec^4 \theta - \tan^4 \theta = 3 \tan \theta$   
 $\Rightarrow \sec^2 \theta + \tan^2 \theta = 3 \tan \theta$  [using part (a)]  
 $\Rightarrow (1 + \tan^2 \theta) + \tan^2 \theta = 3 \tan \theta$   
 $\Rightarrow 2 \tan^2 \theta - 3 \tan \theta + 1 = 0$   
 $\Rightarrow (2 \tan \theta - 1) (\tan \theta - 1) = 0$   
 $\Rightarrow \tan \theta = \frac{1}{2} \text{ or } \tan \theta = 1$

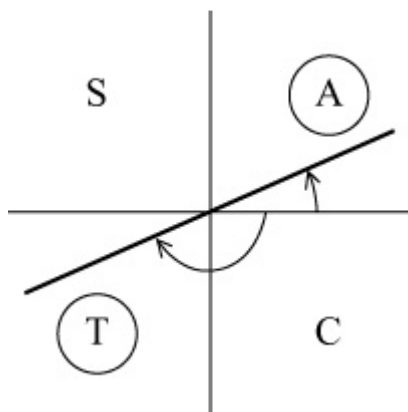

In the interval  $-180^\circ \leq \theta \leq 180^\circ$

$\tan \theta = \frac{1}{2} \Rightarrow \theta = \tan^{-1} \frac{1}{2}, -180^\circ + \tan^{-1}$

$$\frac{1}{2} = 26.6^\circ, \quad -153.4^\circ$$

$$\tan \theta = 1 \Rightarrow \theta = \tan^{-1} 1, \quad -180^\circ + \tan^{-1} 1 = 45^\circ, \quad -135^\circ$$

Set of solutions:  $-153.4^\circ, -135^\circ, 26.6^\circ, 45^\circ$  (3 s.f.)

© Pearson Education Ltd 2008

# Solutionbank

## Edexcel AS and A Level Modular Mathematics

Exercise F, Question 20

### Question:

(Although integration is not in the specification for C3, this question only requires you to know that the area under a curve can be represented by an integral.)

(a) Sketch the graph of  $y = \sin x$  and shade in the area representing  $\int_0^{\frac{\pi}{2}} \sin x \, dx$ .

$$\frac{\pi}{2} \sin x \, dx.$$

(b) Sketch the graph of  $y = \arcsin x$  and shade in the area representing  $\int_0^1 \arcsin x \, dx$ .

(c) By considering the shaded areas explain why  $\int_0^{\frac{\pi}{2}} \sin x \, dx + \int_0^1 \arcsin x \, dx = \frac{\pi}{2}$ .

$$\frac{\pi}{2} \sin x \, dx + \int_0^1 \arcsin x \, dx = \frac{\pi}{2}.$$

### Solution:

(a)  $y = \sin x$

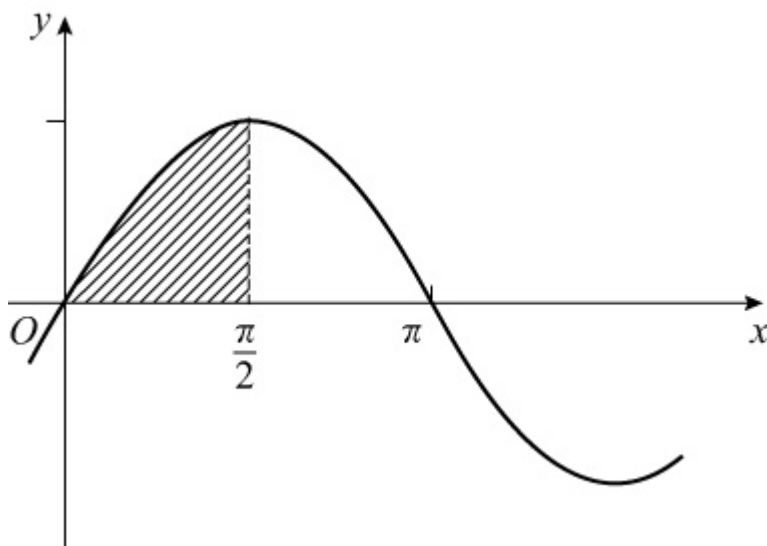

$\int_0^{\frac{\pi}{2}} \sin x \, dx$  represents the area between  $y = \sin x$ ,  $x$ -axis and  $x = \frac{\pi}{2}$ .

(b)  $y = \arcsin x$ ,  $-1 \leq x \leq 1$

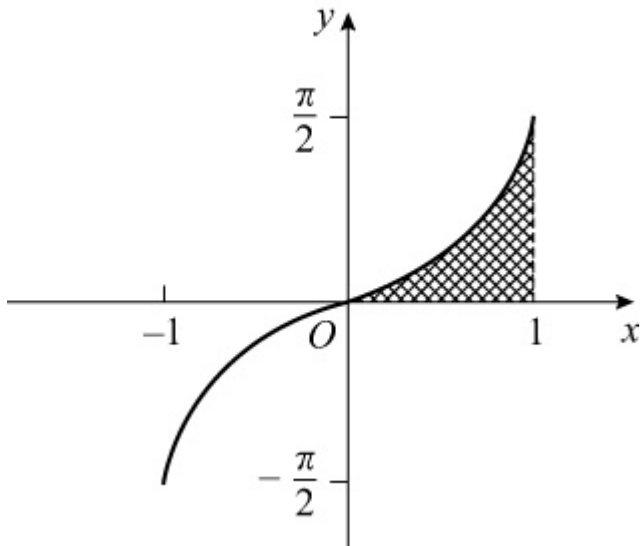

$\int_0^1 \arcsin x \, dx$  represents the area between the curve,  $x$ -axis and  $x = 1$ .

(c) The curves are the same with the axes interchanged.

The shaded area in (b) could be added to the graph in (a) to form a rectangle with sides 1 and  $\frac{\pi}{2}$ , as in the diagram.

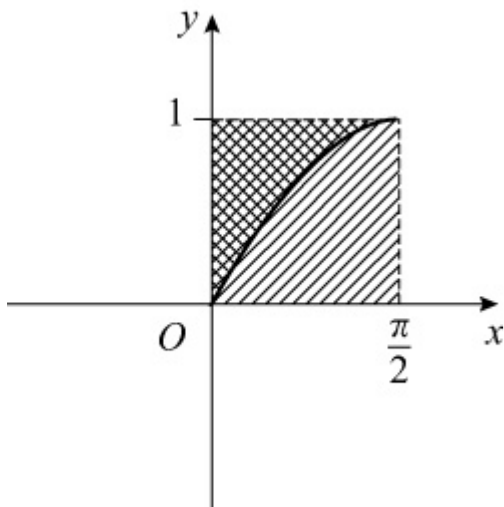

$$\text{Area of rectangle} = \frac{\pi}{2}$$

$$\text{So } \int_0^{\frac{\pi}{2}} \sin x \, dx + \int_0^1 \arcsin x \, dx = \frac{\pi}{2}$$

# Solutionbank

## Edexcel AS and A Level Modular Mathematics

### Exercise A, Question 1

#### Question:

A student makes the mistake of thinking that  $\sin ( A + B ) \equiv \sin A + \sin B$  .  
Choose non-zero values of  $A$  and  $B$  to show that this statement is not true for all values of  $A$  and  $B$ .

#### Solution:

Example: Take  $A = 30^\circ$  ,  $B = 60^\circ$

$$\sin A = \frac{1}{2}$$

$$\sin B = \frac{\sqrt{3}}{2}$$

$$\sin A + \sin B \neq 1$$

$$\text{but } \sin ( A + B ) = \sin 90^\circ = 1 .$$

This proves that  $\sin ( A + B ) = \sin A + \sin B$  is *not* true for all values. There will be many values of  $A$  and  $B$  for which it is true, e.g.  $A = -30^\circ$  and  $B = +30^\circ$  , and that is the danger of trying to prove a statement by taking particular examples. To prove a statement requires a sound argument; to disprove only requires one example.



# Solutionbank

## Edexcel AS and A Level Modular Mathematics

Exercise A, Question 2

### Question:

Using the expansion of  $\cos ( A - B )$  with  $A = B = \theta$ , show that  $\sin^2 \theta + \cos^2 \theta \equiv 1$ .

### Solution:

$$\cos ( A - B ) \equiv \cos A \cos B + \sin A \sin B$$

$$\text{Set } A = \theta, B = \theta$$

$$\Rightarrow \cos ( \theta - \theta ) \equiv \cos \theta \cos \theta + \sin \theta \sin \theta$$

$$\Rightarrow \cos 0 \equiv \cos^2 \theta + \sin^2 \theta$$

$$\text{So } \cos^2 \theta + \sin^2 \theta \equiv 1 \quad (\text{since } \cos 0 = 1)$$

© Pearson Education Ltd 2008

# Solutionbank

## Edexcel AS and A Level Modular Mathematics

### Exercise A, Question 3

#### Question:

(a) Use the expansion of  $\sin (A - B)$  to show that  $\sin \left( \frac{\pi}{2} - \theta \right) = \cos \theta$ .

(b) Use the expansion of  $\cos (A - B)$  to show that  $\cos \left( \frac{\pi}{2} - \theta \right) = \sin \theta$ .

#### Solution:

(a)  $\sin (A - B) \equiv \sin A \cos B - \cos A \sin B$

Set  $A = \frac{\pi}{2}$ ,  $B = \theta$

$$\Rightarrow \sin \left( \frac{\pi}{2} - \theta \right) \equiv \sin \frac{\pi}{2} \cos \theta - \cos \frac{\pi}{2} \sin \theta$$

$$\Rightarrow \sin \left( \frac{\pi}{2} - \theta \right) \equiv \cos \theta \quad (\text{since } \sin \frac{\pi}{2} = 1, \cos \frac{\pi}{2} = 0)$$

(b)  $\cos (A - B) \equiv \cos A \cos B + \sin A \sin B$

Set  $A = \frac{\pi}{2}$ ,  $B = \theta$

$$\Rightarrow \cos \left( \frac{\pi}{2} - \theta \right) \equiv \cos \frac{\pi}{2} \cos \theta + \sin \frac{\pi}{2} \sin \theta$$

$$\Rightarrow \cos \left( \frac{\pi}{2} - \theta \right) \equiv \sin \theta \quad (\text{since } \cos \frac{\pi}{2} = 0, \sin \frac{\pi}{2} = 1)$$

# Solutionbank

## Edexcel AS and A Level Modular Mathematics

### Exercise A, Question 4

#### Question:

Express the following as a single sine, cosine or tangent:

(a)  $\sin 15^\circ \cos 20^\circ + \cos 15^\circ \sin 20^\circ$

(b)  $\sin 58^\circ \cos 23^\circ - \cos 58^\circ \sin 23^\circ$

(c)  $\cos 130^\circ \cos 80^\circ - \sin 130^\circ \sin 80^\circ$

(d)  $\frac{\tan 76^\circ - \tan 45^\circ}{1 + \tan 76^\circ \tan 45^\circ}$

(e)  $\cos 2\theta \cos \theta + \sin 2\theta \sin \theta$

(f)  $\cos 4\theta \cos 3\theta - \sin 4\theta \sin 3\theta$

(g)  $\sin \frac{1}{2}\theta \cos 2\frac{1}{2}\theta + \cos \frac{1}{2}\theta \sin 2\frac{1}{2}\theta$

(h)  $\frac{\tan 2\theta + \tan 3\theta}{1 - \tan 2\theta \tan 3\theta}$

(i)  $\sin (A + B) \cos B - \cos (A + B) \sin B$

(j)  $\cos \left( \frac{3x + 2y}{2} \right) \cos \left( \frac{3x - 2y}{2} \right) - \sin \left( \frac{3x + 2y}{2} \right) \sin \left( \frac{3x - 2y}{2} \right)$

#### Solution:

(a) Using  $\sin (A + B) \equiv \sin A \cos B + \cos A \sin B$

$$\sin 15^\circ \cos 20^\circ + \cos 15^\circ \sin 20^\circ \equiv \sin (15^\circ + 20^\circ) \equiv \sin 35^\circ$$

(b) Using  $\sin (A - B) \equiv \sin A \cos B - \cos A \sin B$

$$\sin 58^\circ \cos 23^\circ - \cos 58^\circ \sin 23^\circ \equiv \sin (58^\circ - 23^\circ) \equiv \sin 35^\circ$$

(c) Using  $\cos (A + B) \equiv \cos A \cos B - \sin A \sin B$

$$\cos 130^\circ \cos 80^\circ - \sin 130^\circ \sin 80^\circ \equiv \cos (130^\circ + 80^\circ) \equiv \cos 210^\circ$$

(d) Using  $\tan (A - B) \equiv \frac{\tan A - \tan B}{1 + \tan A \tan B}$

$$\frac{\tan 76^\circ - \tan 45^\circ}{1 + \tan 76^\circ \tan 45^\circ} \equiv \tan (76^\circ - 45^\circ) \equiv \tan 31^\circ$$

(e) Using  $\cos (A - B) \equiv \cos A \cos B + \sin A \sin B$   
 $\cos 2\theta \cos \theta + \sin 2\theta \sin \theta \equiv \cos (2\theta - \theta) \equiv \cos \theta$

(f) Using  $\cos (A + B) \equiv \cos A \cos B - \sin A \sin B$   
 $\cos 4\theta \cos 3\theta - \sin 4\theta \sin 3\theta \equiv \cos (4\theta + 3\theta) \equiv \cos 7\theta$

(g) Using  $\sin (A + B) \equiv \sin A \cos B + \cos A \sin B$   
 $\sin \frac{1}{2}\theta \cos 2\frac{1}{2}\theta + \cos \frac{1}{2}\theta \sin 2\frac{1}{2}\theta \equiv \sin \left( \frac{1}{2}\theta + 2\frac{1}{2}\theta \right) \equiv \sin 3\theta$

(h) Using  $\tan (A + B) \equiv \frac{\tan A + \tan B}{1 - \tan A \tan B}$

$$\frac{\tan 2\theta + \tan 3\theta}{1 - \tan 2\theta \tan 3\theta} \equiv \tan (2\theta + 3\theta) \equiv \tan 5\theta$$

(i) Using  $\sin (P - Q) \equiv \sin P \cos Q - \cos P \sin Q$   
 $\sin (A + B) \cos B - \cos (A + B) \sin B \equiv \sin [ (A + B) - B ] \equiv \sin A$

(j) Using  $\cos (A + B) \equiv \cos A \cos B - \sin A \sin B$   
 $\cos \left( \frac{3x + 2y}{2} \right) \cos \left( \frac{3x - 2y}{2} \right) - \sin \left( \frac{3x + 2y}{2} \right) \sin \left( \frac{3x - 2y}{2} \right)$   
 $\equiv \cos \left[ \left( \frac{3x + 2y}{2} \right) + \left( \frac{3x - 2y}{2} \right) \right] \equiv \cos \left( \frac{6x}{2} \right) \equiv \cos 3x$

# Solutionbank

## Edexcel AS and A Level Modular Mathematics

### Exercise A, Question 5

#### Question:

Calculate, without using your calculator, the exact value of:

(a)  $\sin 30^\circ \cos 60^\circ + \cos 30^\circ \sin 60^\circ$

(b)  $\cos 110^\circ \cos 20^\circ + \sin 110^\circ \sin 20^\circ$

(c)  $\sin 33^\circ \cos 27^\circ + \cos 33^\circ \sin 27^\circ$

(d)  $\cos \frac{\pi}{8} \cos \frac{\pi}{8} - \sin \frac{\pi}{8} \sin \frac{\pi}{8}$

(e)  $\sin 60^\circ \cos 15^\circ - \cos 60^\circ \sin 15^\circ$

(f)  $\cos 70^\circ (\cos 50^\circ - \tan 70^\circ \sin 50^\circ)$

(g)  $\frac{\tan 45^\circ + \tan 15^\circ}{1 - \tan 45^\circ \tan 15^\circ}$

(h)  $\frac{1 - \tan 15^\circ}{1 + \tan 15^\circ}$

(i)  $\frac{\tan \left( \frac{7\pi}{12} \right) - \tan \left( \frac{\pi}{3} \right)}{1 + \tan \left( \frac{7\pi}{12} \right) \tan \left( \frac{\pi}{3} \right)}$

(j)  $\sqrt{3} \cos 15^\circ - \sin 15^\circ$

#### Solution:

(a) Using  $\sin (A + B)$  expansion

$$\sin 30^\circ \cos 60^\circ + \cos 30^\circ \sin 60^\circ = \sin (30 + 60)^\circ = \sin 90^\circ = 1$$

(b)  $\cos 110^\circ \cos 20^\circ + \sin 110^\circ \sin 20^\circ = \cos (110 - 20)^\circ = \cos 90^\circ = 0$

(c)  $\sin 33^\circ \cos 27^\circ + \cos 33^\circ \sin 27^\circ = \sin (33 + 27)^\circ = \sin 60^\circ = \frac{\sqrt{3}}{2}$

(d)  $\cos \frac{\pi}{8} \cos \frac{\pi}{8} - \sin \frac{\pi}{8} \sin \frac{\pi}{8} = \cos \left( \frac{\pi}{8} + \frac{\pi}{8} \right) = \cos \frac{\pi}{4} = \frac{\sqrt{2}}{2}$

(e)  $\sin 60^\circ \cos 15^\circ - \cos 60^\circ \sin 15^\circ = \sin (60 - 15)^\circ = \sin 45^\circ = \frac{\sqrt{2}}{2}$

$$(f) \cos 70^\circ \cos 50^\circ - \cos 70^\circ \tan 70^\circ \sin 50^\circ \\ = \cos 70^\circ \cos 50^\circ - \sin 70^\circ \sin 50^\circ$$

$$\left( \cos \theta \times \tan \theta = \cancel{\cos \theta} \times \frac{\sin \theta}{\cancel{\cos \theta}} = \sin \theta \right) \\ = \cos ( 70 + 50 ) \\ = \cos 120^\circ \\ = -\cos 60^\circ = -\frac{1}{2}$$

$$(g) \frac{\tan 45^\circ + \tan 15^\circ}{1 - \tan 45^\circ \tan 15^\circ} = \tan ( 45 + 15 )^\circ = \tan 60^\circ = \sqrt{3}$$

$$(h) \frac{1 - \tan 15^\circ}{1 + \tan 15^\circ} = \frac{\tan 45^\circ - \tan 15^\circ}{1 + \tan 45^\circ \tan 15^\circ} \quad (\text{using } \tan 45^\circ = 1) \\ = \tan ( 45 - 15 )^\circ = \tan 30^\circ = \frac{\sqrt{3}}{3}$$

$$(i) \frac{\tan \left( \frac{7\pi}{12} \right) - \tan \left( \frac{1}{3}\pi \right)}{1 + \tan \left( \frac{7\pi}{12} \right) \tan \left( \frac{1}{3}\pi \right)} = \tan \left( \frac{7\pi}{12} - \frac{\pi}{3} \right) = \tan \frac{3\pi}{12} = \tan \frac{\pi}{4} = 1$$

(j) This is very similar to part (e) but you need to rewrite it as  $2 \left( \frac{\sqrt{3}}{2} \cos 15^\circ - \frac{1}{2} \sin 15^\circ \right)$  to appreciate it!

$$\sqrt{3} \cos 15^\circ - \sin 15^\circ \equiv 2 \left( \frac{\sqrt{3}}{2} \cos 15^\circ - \frac{1}{2} \sin 15^\circ \right) \\ \equiv 2 ( \sin 60^\circ \cos 15^\circ - \cos 60^\circ \sin 15^\circ ) \\ \equiv 2 \sin ( 60 - 15 )^\circ \\ \equiv 2 \sin 45^\circ \\ = \sqrt{2}$$

# Solutionbank

## Edexcel AS and A Level Modular Mathematics

Exercise A, Question 6

### Question:

Triangle  $ABC$  is such that  $AB = 3$  cm,  $BC = 4$  cm,  $\angle ABC = 120^\circ$  and  $\angle BAC = \theta^\circ$ .

(a) Write down, in terms of  $\theta$ , an expression for  $\angle ACB$ .

(b) Using the sine rule, or otherwise, show that  $\tan \theta^\circ = \frac{2\sqrt{3}}{5}$ .

### Solution:

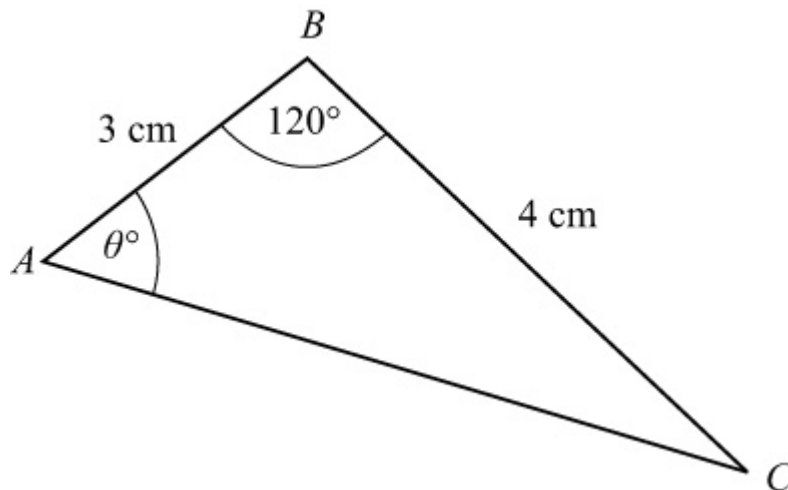

(a)  $\angle ACB = 180^\circ - 120^\circ - \theta^\circ = (60 - \theta)^\circ$

(b) Using sine rule:  $\frac{\sin C}{c} = \frac{\sin A}{a}$

$$\Rightarrow \frac{\sin(60 - \theta)^\circ}{3} = \frac{\sin \theta^\circ}{4}$$

$$\Rightarrow 4 \sin(60 - \theta)^\circ = 3 \sin \theta^\circ$$

$$\Rightarrow 4 \sin 60^\circ \cos \theta^\circ - 4 \cos 60^\circ \sin \theta^\circ = 3 \sin \theta^\circ$$

$$\Rightarrow 2\sqrt{3} \cos \theta^\circ - 2 \sin \theta^\circ = 3 \sin \theta^\circ \quad \left( \sin 60^\circ = \frac{\sqrt{3}}{2} \right)$$

$$\Rightarrow 5 \sin \theta^\circ = 2\sqrt{3} \cos \theta^\circ$$

$$\Rightarrow \frac{\sin \theta^\circ}{\cos \theta^\circ} = \frac{2\sqrt{3}}{5}$$

$$\Rightarrow \tan \theta^\circ = \frac{2\sqrt{3}}{5}$$

© Pearson Education Ltd 2008



# Solutionbank

## Edexcel AS and A Level Modular Mathematics

### Exercise A, Question 7

#### Question:

Prove the identities

$$(a) \sin ( A + 60^\circ ) + \sin ( A - 60^\circ ) \equiv \sin A$$

$$(b) \frac{\cos A}{\sin B} - \frac{\sin A}{\cos B} \equiv \frac{\cos ( A + B )}{\sin B \cos B}$$

$$(c) \frac{\sin ( x + y )}{\cos x \cos y} \equiv \tan x + \tan y$$

$$(d) \frac{\cos ( x + y )}{\sin x \sin y} + 1 \equiv \cot x \cot y$$

$$(e) \cos \left( \theta + \frac{\pi}{3} \right) + \sqrt{3} \sin \theta \equiv \sin \left( \theta + \frac{\pi}{6} \right)$$

$$(f) \cot ( A + B ) \equiv \frac{\cot A \cot B - 1}{\cot A + \cot B}$$

$$(g) \sin^2 ( 45 + \theta )^\circ + \sin^2 ( 45 - \theta )^\circ \equiv 1$$

$$(h) \cos ( A + B ) \cos ( A - B ) \equiv \cos^2 A - \sin^2 B$$

#### Solution:

$$\begin{aligned} (a) \text{ L.H.S. } &\equiv \sin ( A + 60^\circ ) + \sin ( A - 60^\circ ) \\ &\equiv \sin A \cos 60^\circ + \cos A \sin 60^\circ + \sin A \cos 60^\circ - \cos A \sin 60^\circ \\ &\equiv 2 \sin A \cos 60^\circ \\ &\equiv \sin A \quad \left( \text{since } \cos 60^\circ = \frac{1}{2} \right) \\ &\equiv \text{ R.H.S.} \end{aligned}$$

$$\begin{aligned} (b) \text{ L.H.S. } &\equiv \frac{\cos A}{\sin B} - \frac{\sin A}{\cos B} \\ &\equiv \frac{\cos A \cos B - \sin A \sin B}{\sin B \cos B} \\ &\equiv \frac{\cos ( A + B )}{\sin B \cos B} \\ &\equiv \text{ R.H.S.} \end{aligned}$$

$$(c) \text{ L.H.S. } \equiv \frac{\sin ( x + y )}{\cos x \cos y}$$

$$\begin{aligned}
&\equiv \frac{\sin x \cos y + \cos x \sin y}{\cos x \cos y} \\
&\equiv \frac{\sin x \cos y}{\cos x \cos y} + \frac{\cos x \sin y}{\cos x \cos y} \\
&\equiv \frac{\sin x}{\cos x} + \frac{\sin y}{\cos y} \\
&\equiv \tan x + \tan y \\
&\equiv \text{R.H.S.}
\end{aligned}$$

$$\begin{aligned}
\text{(d) L.H.S.} &\equiv \frac{\cos(x+y)}{\sin x \sin y} + 1 \\
&\equiv \frac{\cos(x+y) + \sin x \sin y}{\sin x \sin y} \\
&\equiv \frac{\cos x \cos y - \sin x \sin y + \sin x \sin y}{\sin x \sin y} \\
&\equiv \frac{\cos x \cos y}{\sin x \sin y} \\
&\equiv \cot x \cot y \\
&\equiv \text{R.H.S.}
\end{aligned}$$

$$\begin{aligned}
\text{(e) L.H.S.} &\equiv \cos\left(\theta + \frac{\pi}{3}\right) + \sqrt{3} \sin \theta \\
&\equiv \cos \theta \cos \frac{\pi}{3} - \sin \theta \sin \frac{\pi}{3} + \sqrt{3} \sin \theta \\
&\equiv \frac{1}{2} \cos \theta - \frac{\sqrt{3}}{2} \sin \theta + \sqrt{3} \sin \theta \\
&\equiv \frac{\sqrt{3}}{2} \sin \theta + \frac{1}{2} \cos \theta \\
&\equiv \sin \theta \cos \frac{\pi}{6} + \cos \theta \sin \frac{\pi}{6} \quad \left( \cos \frac{\pi}{6} = \frac{\sqrt{3}}{2}, \sin \frac{\pi}{6} = \frac{1}{2} \right) \\
&\equiv \sin\left(\theta + \frac{\pi}{6}\right) \quad [ \sin(A+B) ] \\
&\equiv \text{R.H.S.}
\end{aligned}$$

(f)

$$\begin{aligned}
\text{R.H.S.} &\equiv \frac{\cot A \cot B - 1}{\cot A + \cot B} \\
&\equiv \frac{\frac{1}{\tan A} \times \frac{1}{\tan B} - 1}{\frac{1}{\tan A} + \frac{1}{\tan B}} \\
&\equiv \frac{1 - \tan A \tan B}{\frac{\tan A \tan B}{\tan B - \tan A}} \\
&\equiv \frac{1 - \tan A \tan B}{\tan A \tan B} \times \frac{\tan A \tan B}{\tan A + \tan B} \\
&\equiv \frac{1 - \tan A \tan B}{\tan A + \tan B} \\
&\equiv \frac{1}{\frac{\tan A + \tan B}{1 - \tan A \tan B}} \\
&\equiv \frac{1}{\tan(A + B)} \\
&\equiv \cot(A + B) \\
&\equiv \text{L.H.S.}
\end{aligned}$$

$$\begin{aligned}
\text{(g) L.H.S.} &\equiv \sin^2(45^\circ + \theta^\circ) + \sin^2(45^\circ - \theta^\circ) \\
&\equiv (\sin 45^\circ \cos \theta^\circ + \cos 45^\circ \sin \theta^\circ)^2 + (\sin 45^\circ \cos \theta^\circ - \cos 45^\circ \sin \theta^\circ)^2
\end{aligned}$$

As  $\sin 45^\circ = \cos 45^\circ$  it is easier to take out as a common factor.

$$\begin{aligned}
&\equiv (\sin 45^\circ)^2 [(\cos \theta^\circ + \sin \theta^\circ)^2 + (\cos \theta^\circ - \sin \theta^\circ)^2] \\
&\equiv \frac{1}{2} \left( \cos^2 \theta^\circ + 2 \sin \theta^\circ \cos \theta^\circ + \sin^2 \theta^\circ + \cos^2 \theta^\circ - 2 \sin \theta^\circ \cos \theta^\circ + \sin^2 \theta^\circ \right) \\
&\equiv \frac{1}{2} \left[ 2 \left( \sin^2 \theta^\circ + \cos^2 \theta^\circ \right) \right] \\
&\equiv \frac{1}{2} \times 2 \quad (\sin^2 \theta^\circ + \cos^2 \theta^\circ \equiv 1) \\
&\equiv 1 \\
&\equiv \text{R.H.S.}
\end{aligned}$$

Alternatively:

as  $\sin(90^\circ - x^\circ) \equiv \cos x^\circ$ ,

if  $x = 45^\circ + \theta^\circ$  then  $\sin(45^\circ - \theta^\circ) \equiv \cos(45^\circ + \theta^\circ)$

and original L.H.S. becomes  $\sin^2(45^\circ + \theta^\circ) + \cos^2(45^\circ + \theta^\circ)$

which is identically = 1

$$\begin{aligned}
\text{(h) L.H.S.} &\equiv \cos(A + B) \cos(A - B) \\
&\equiv (\cos A \cos B - \sin A \sin B)(\cos A \cos B + \sin A \sin B) \\
&\equiv \cos^2 A \cos^2 B - \sin^2 A \sin^2 B
\end{aligned}$$

$$\begin{aligned} &\equiv \cos^2 A (1 - \sin^2 B) - (1 - \cos^2 A) \sin^2 B \\ &\equiv \cos^2 A - \cos^2 A \sin^2 B - \sin^2 B + \cos^2 A \sin^2 B \\ &\equiv \cos^2 A - \sin^2 B \\ &\equiv \text{R.H.S.} \end{aligned}$$

© Pearson Education Ltd 2008

# Solutionbank

## Edexcel AS and A Level Modular Mathematics

### Exercise A, Question 8

#### Question:

Given that  $\sin A = \frac{4}{5}$  and  $\sin B = \frac{1}{2}$ , where  $A$  and  $B$  are both acute angles, calculate the exact values of

(a)  $\sin ( A + B )$

(b)  $\cos ( A - B )$

(c)  $\sec ( A - B )$

#### Solution:

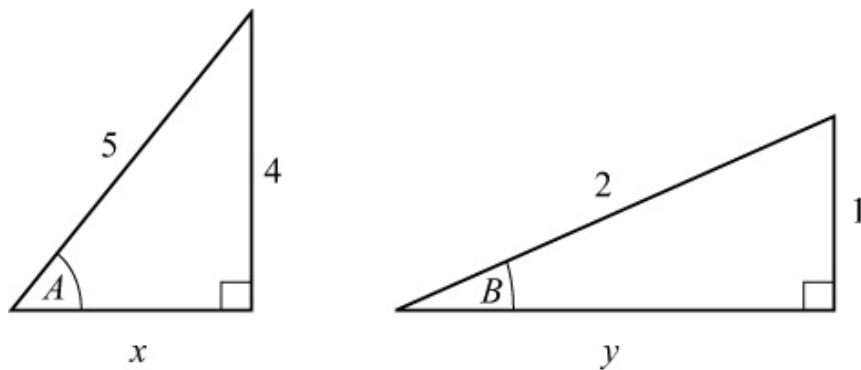

Using Pythagoras' theorem  $x = 3$  and  $y = \sqrt{3}$

$$(a) \sin ( A + B ) = \sin A \cos B + \cos A \sin B = \frac{4}{5} \times \frac{\sqrt{3}}{2} + \frac{3}{5} \times \frac{1}{2} = \frac{4\sqrt{3} + 3}{10}$$

$$(b) \cos ( A - B ) = \cos A \cos B + \sin A \sin B = \frac{3}{5} \times \frac{\sqrt{3}}{2} + \frac{4}{5} \times \frac{1}{2} = \frac{3\sqrt{3} + 4}{10}$$

$$\begin{aligned} (c) \sec ( A - B ) &= \frac{1}{\cos ( A - B )} = \frac{10}{3\sqrt{3} + 4} \\ &= \frac{10(3\sqrt{3} - 4)}{(3\sqrt{3} + 4)(3\sqrt{3} - 4)} \\ &= \frac{10(3\sqrt{3} - 4)}{27 - 16} \\ &= \frac{10(3\sqrt{3} - 4)}{11} \end{aligned}$$

# Solutionbank

## Edexcel AS and A Level Modular Mathematics

### Exercise A, Question 9

#### Question:

Given that  $\cos A = -\frac{4}{5}$ , and  $A$  is an obtuse angle measured in radians, find the exact value of

- (a)  $\sin A$
- (b)  $\cos(\pi + A)$
- (c)  $\sin\left(\frac{\pi}{3} + A\right)$
- (d)  $\tan\left(\frac{\pi}{4} + A\right)$

#### Solution:

Draw a right-angled triangle where  $\cos A' = \frac{4}{5}$

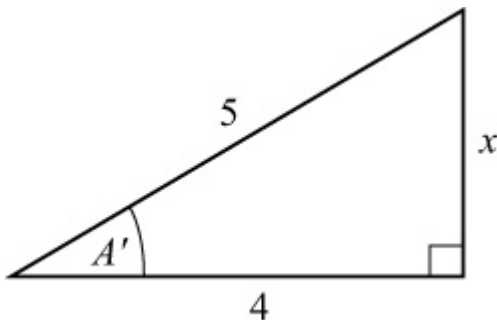

Using Pythagoras' theorem  $x = 3$

So  $\sin A' = \frac{3}{5}$ ,  $\tan A' = \frac{3}{4}$

(a) As  $A$  is in the 2nd quadrant,  $\sin A = \sin A'$

$$\sin A = \frac{3}{5}$$

(b)  $\cos(\pi + A) = \cos \pi \cos A - \sin \pi \sin A = -\cos A$  ( $\cos \pi = -1$ ,  $\sin \pi = 0$ )

$$\cos(\pi + A) = +\frac{4}{5}$$

$$\begin{aligned} \text{(c) } \sin\left(\frac{\pi}{3} + A\right) &= \sin\frac{\pi}{3}\cos A + \cos\frac{\pi}{3}\sin A \\ &= \left(\frac{\sqrt{3}}{2}\right)\left(-\frac{4}{5}\right) + \left(\frac{1}{2}\right)\left(\frac{3}{5}\right) \\ &= \frac{3 - 4\sqrt{3}}{10} \end{aligned}$$

$$\text{(d) As } A \text{ is in 2nd quadrant, } \tan A = -\tan A' = -\frac{3}{4}$$

$$\tan\left(\frac{\pi}{4} + A\right) = \frac{\tan\frac{\pi}{4} + \tan A}{1 - \tan\frac{\pi}{4}\tan A} = \frac{1 + \tan A}{1 - \tan A} = \frac{\frac{1}{4}}{\frac{7}{4}} = \frac{1}{7}$$

# Solutionbank

## Edexcel AS and A Level Modular Mathematics

### Exercise A, Question 10

#### Question:

Given that  $\sin A = \frac{8}{17}$ , where  $A$  is acute, and  $\cos B = -\frac{4}{5}$ , where  $B$  is obtuse, calculate the exact value of

(a)  $\sin ( A - B )$

(b)  $\cos ( A - B )$

(c)  $\cot ( A - B )$

#### Solution:

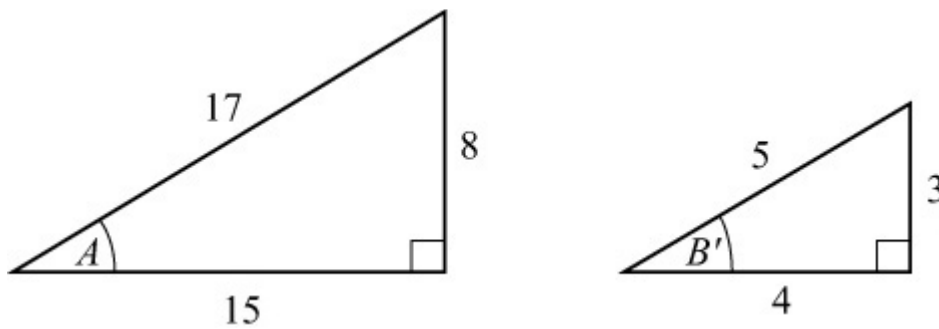

$$\sin B = \sin B', \tan B = -\tan B'$$

By Pythagoras' theorem, the remaining sides are 15 and 3.

$$\text{So } \sin A = \frac{8}{17}, \cos A = \frac{15}{17}, \tan A = \frac{8}{15}$$

$$\text{and } \sin B = \frac{3}{5}, \cos B = -\frac{4}{5}, \tan B = -\frac{3}{4}$$

$$\begin{aligned} \text{(a) } \sin ( A - B ) &= \sin A \cos B - \cos A \sin B \\ &= \left( \frac{8}{17} \right) \left( -\frac{4}{5} \right) - \left( \frac{15}{17} \right) \left( \frac{3}{5} \right) \\ &= \frac{-32 - 45}{85} = -\frac{77}{85} \end{aligned}$$

$$\begin{aligned} \text{(b) } \cos ( A - B ) &= \cos A \cos B + \sin A \sin B \\ &= \left( \frac{15}{17} \right) \left( -\frac{4}{5} \right) + \left( \frac{8}{17} \right) \left( \frac{3}{5} \right) \end{aligned}$$



$$= \frac{-60 + 24}{85} = -\frac{36}{85}$$

$$(c) \tan(A - B) = \frac{\tan A - \tan B}{1 + \tan A \tan B} = \frac{\frac{8}{15} + \frac{3}{4}}{1 - \frac{24}{60}} = \frac{\frac{77}{60}}{\frac{36}{60}} = \frac{77}{36}$$

$$\text{So } \cot(A - B) = \frac{1}{\tan(A - B)} = \frac{36}{77}$$

© Pearson Education Ltd 2008

# Solutionbank

## Edexcel AS and A Level Modular Mathematics

### Exercise A, Question 11

#### Question:

Given that  $\tan A = \frac{7}{24}$ , where  $A$  is reflex, and  $\sin B = \frac{5}{13}$ , where  $B$  is obtuse, calculate the exact value of

- (a)  $\sin ( A + B )$   
 (b)  $\tan ( A - B )$   
 (c)  $\operatorname{cosec} ( A + B )$

#### Solution:

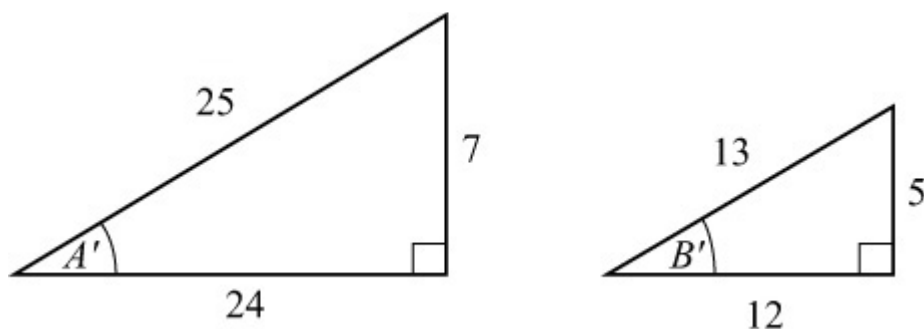

Using Pythagoras' theorem, the remaining sides are 25 and 12.

As  $A$  is in the 3rd quadrant ( $\tan A$  is +ve, and  $A$  is reflex),

$$\sin A = -\sin A', \cos A = -\cos A'$$

$$\text{So } \sin A = -\frac{7}{25}, \cos A = -\frac{24}{25}, \tan A = \frac{7}{24}$$

As  $B$  is in the 2nd quadrant,

$$\cos B = -\cos B', \tan B = -\tan B'$$

$$\text{So } \sin B = \frac{5}{13}, \cos B = -\frac{12}{13}, \tan B = -\frac{5}{12}$$

(a)

$$\begin{aligned} \sin ( A + B ) &= \sin A \cos B + \cos A \sin B \\ &= \left( -\frac{7}{25} \right) \left( -\frac{12}{13} \right) + \left( -\frac{24}{25} \right) \left( \frac{5}{13} \right) \\ &= \frac{84 - 120}{325} = -\frac{36}{325} \end{aligned}$$

$$(b) \tan (A - B) = \frac{\tan A - \tan B}{1 + \tan A \tan B} = \frac{\frac{7}{24} + \frac{5}{12}}{1 - \left(\frac{7}{24}\right)\left(\frac{5}{12}\right)} = \frac{\frac{17}{24}}{\frac{253}{288}} = \frac{204}{253}$$

$$(c) \operatorname{cosec} (A + B) = \frac{1}{\sin (A + B)} = -\frac{325}{36}$$

© Pearson Education Ltd 2008

# Solutionbank

## Edexcel AS and A Level Modular Mathematics

### Exercise A, Question 12

#### Question:

Write the following as a single trigonometric function, assuming that  $\theta$  is measured in radians:

(a)  $\cos^2 \theta - \sin^2 \theta$

(b)  $2 \sin 4\theta \cos 4\theta$

(c)  $\frac{1 + \tan \theta}{1 - \tan \theta}$

(d)  $\frac{1}{\sqrt{2}} (\sin \theta + \cos \theta)$

#### Solution:

(a)  $\cos^2 \theta - \sin^2 \theta = \cos \theta \cos \theta - \sin \theta \sin \theta = \cos (\theta + \theta) = \cos 2\theta$

(b)  $2 \sin 4\theta \cos 4\theta = \sin 4\theta \cos 4\theta + \sin 4\theta \cos 4\theta$   
 $= \sin 4\theta \cos 4\theta + \cos 4\theta \sin 4\theta$   
 $= \sin (4\theta + 4\theta)$   
 $= \sin 8\theta$

(c)  $\frac{1 + \tan \theta}{1 - \tan \theta} = \frac{\tan \frac{\pi}{4} + \tan \theta}{1 - \tan \frac{\pi}{4} \tan \theta} \quad (\text{as } \tan \frac{\pi}{4} = 1)$   
 $= \tan \left( \frac{\pi}{4} + \theta \right)$

(d)  $\frac{1}{\sqrt{2}} \sin \theta + \frac{1}{\sqrt{2}} \cos \theta = \sin \theta \cos \frac{\pi}{4} + \cos \theta \sin \frac{\pi}{4} \quad (\text{as } \frac{1}{\sqrt{2}} = \cos \frac{\pi}{4} = \sin \frac{\pi}{4})$   
 $= \sin \left( \theta + \frac{\pi}{4} \right)$

[ **Note:** (d) could be  $\cos \left( \theta - \frac{\pi}{4} \right)$  ]

© Pearson Education Ltd 2008

# Solutionbank

## Edexcel AS and A Level Modular Mathematics

### Exercise A, Question 13

#### Question:

Solve, in the interval  $0^\circ \leq \theta < 360^\circ$ , the following equations. Give answers to the nearest  $0.1^\circ$ .

(a)  $3 \cos \theta = 2 \sin (\theta + 60^\circ)$

(b)  $\sin (\theta + 30^\circ) + 2 \sin \theta = 0$

(c)  $\cos (\theta + 25^\circ) + \sin (\theta + 65^\circ) = 1$

(d)  $\cos \theta = \cos (\theta + 60^\circ)$

(e)  $\tan (\theta - 45^\circ) = 6 \tan \theta$

(f)  $\sin \theta + \cos \theta = 1$

#### Solution:

(a)  $3 \cos \theta = 2 \sin (\theta + 60^\circ)$

$$\Rightarrow 3 \cos \theta = 2 (\sin \theta \cos 60^\circ + \cos \theta \sin 60^\circ)$$

$$\Rightarrow 3 \cos \theta = 2 \left( \frac{1}{2} \sin \theta + \frac{\sqrt{3}}{2} \cos \theta \right) = \sin \theta + \sqrt{3} \cos \theta$$

$$\Rightarrow (3 - \sqrt{3}) \cos \theta = \sin \theta$$

$$\Rightarrow \tan \theta = 3 - \sqrt{3} \quad \left( \tan \theta = \frac{\sin \theta}{\cos \theta} \right)$$

As  $\tan \theta$  is +ve,  $\theta$  is in 1st and 3rd quadrants.

$$\theta = \tan^{-1} (3 - \sqrt{3}), 180^\circ + \tan^{-1} (3 - \sqrt{3}) = 51.7^\circ, 231.7^\circ$$

(b)  $\sin (\theta + 30^\circ) + 2 \sin \theta = 0$

$$\Rightarrow \sin \theta \cos 30^\circ + \cos \theta \sin 30^\circ + 2 \sin \theta = 0$$

$$\Rightarrow \frac{\sqrt{3}}{2} \sin \theta + \frac{1}{2} \cos \theta + 2 \sin \theta = 0$$

$$\Rightarrow (4 + \sqrt{3}) \sin \theta = -\cos \theta$$

$$\Rightarrow \tan \theta = -\frac{1}{4 + \sqrt{3}}$$

As  $\tan \theta$  is -ve,  $\theta$  is in the 2nd and 4th quadrants.

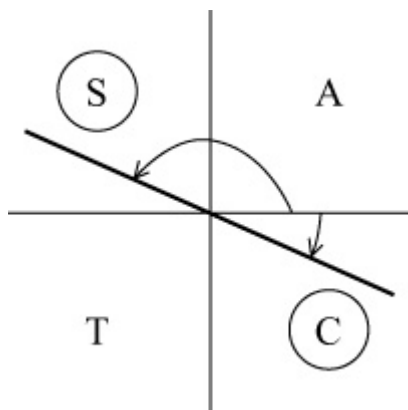

$$\theta = \tan^{-1} \left( -\frac{1}{4 + \sqrt{3}} \right) + 180^\circ, \tan^{-1} \left( -\frac{1}{4 + \sqrt{3}} \right) + 360^\circ$$

$$= 170.1^\circ, 350.1^\circ.$$

$$(c) \cos(\theta + 25^\circ) + \sin(\theta + 65^\circ) = 1$$

$$\Rightarrow \cos\theta \cos 25^\circ - \sin\theta \sin 25^\circ + \sin\theta \cos 65^\circ + \cos\theta \sin 65^\circ = 1$$

As  $\sin(90 - x)^\circ = \cos x^\circ$  and  $\cos(90 - x)^\circ = \sin x^\circ$

$\cos 25^\circ = \sin 65^\circ$  and  $\sin 25^\circ = \cos 65^\circ$

So  $\cos\theta \sin 65^\circ - \sin\theta \cos 65^\circ + \sin\theta \cos 65^\circ + \cos\theta \sin 65^\circ = 1$

$$\Rightarrow 2 \cos\theta \sin 65^\circ = 1$$

$$\Rightarrow \cos\theta = \frac{1}{2 \sin 65^\circ} = 0.55169$$

$$\theta = \cos^{-1}(0.55169), 360^\circ - \cos^{-1}(0.55169) = 56.5^\circ, 303.5^\circ$$

$$(d) \cos\theta = \cos(\theta + 60^\circ)$$

$$\Rightarrow \cos\theta = \cos\theta \cos 60^\circ - \sin\theta \sin 60^\circ = \frac{1}{2} \cos\theta - \frac{\sqrt{3}}{2} \sin\theta$$

$$\Rightarrow \cos\theta = -\sqrt{3} \sin\theta$$

$$\Rightarrow \tan\theta = -\frac{1}{\sqrt{3}} \quad \left( \tan\theta = \frac{\sin\theta}{\cos\theta} \right)$$

$\theta$  is in the 2nd and 4th quadrants.

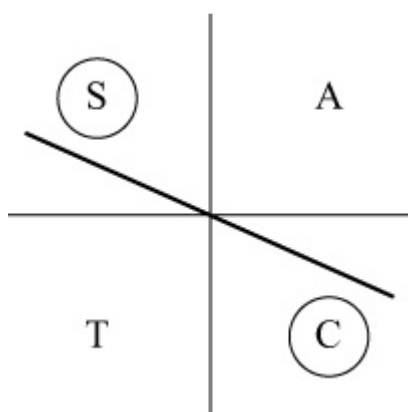

$\tan^{-1} \left( -\frac{1}{\sqrt{3}} \right)$  is not in given interval.

$$\theta = \tan^{-1} \left( -\frac{1}{\sqrt{3}} \right) + 180^\circ, \tan^{-1} \left( -\frac{1}{\sqrt{3}} \right) + 360^\circ = 150^\circ, 330^\circ$$

(e)  $\tan(\theta - 45^\circ) = 6 \tan \theta$

$$\Rightarrow \frac{\tan \theta - \tan 45^\circ}{1 + \tan \theta \tan 45^\circ} = 6 \tan \theta$$

$$\Rightarrow \frac{\tan \theta - 1}{1 + \tan \theta} = 6 \tan \theta$$

$$\Rightarrow \tan \theta - 1 = 6 \tan \theta + 6 \tan^2 \theta$$

$$\Rightarrow 6 \tan^2 \theta + 5 \tan \theta + 1 = 0$$

$$\Rightarrow (3 \tan \theta + 1)(2 \tan \theta + 1) = 0$$

$$\Rightarrow \tan \theta = -\frac{1}{3} \text{ or } \tan \theta = -\frac{1}{2}$$

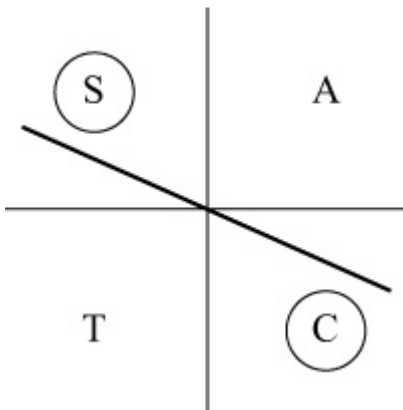

$$\tan \theta = -\frac{1}{3} \Rightarrow \theta = \tan^{-1} \left( -\frac{1}{3} \right) + 180^\circ, \tan^{-1} \left( -\frac{1}{3} \right) + 360^\circ = 161.6^\circ, 341.6^\circ$$

$$\tan \theta = -\frac{1}{2} \Rightarrow \theta = \tan^{-1} \left( -\frac{1}{2} \right) + 180^\circ, \tan^{-1} \left( -\frac{1}{2} \right) + 360^\circ = 153.4^\circ, 333.4^\circ$$

Set of solutions:  $153.4^\circ, 161.6^\circ, 333.4^\circ, 341.6^\circ$

(f)  $\sin \theta + \cos \theta = 1$

$$\Rightarrow \frac{1}{\sqrt{2}} \sin \theta + \frac{1}{\sqrt{2}} \cos \theta = \frac{1}{\sqrt{2}}$$



$$\Rightarrow \cos 45^\circ \sin \theta + \sin 45^\circ \cos \theta = \frac{1}{\sqrt{2}}$$

$$\Rightarrow \sin (\theta + 45^\circ) = \frac{1}{\sqrt{2}}$$

$$\Rightarrow \theta + 45^\circ = 45^\circ, 135^\circ$$

$$\Rightarrow \theta = 0^\circ, 90^\circ$$

# Solutionbank

## Edexcel AS and A Level Modular Mathematics

### Exercise A, Question 14

#### Question:

(a) Solve the equation  $\cos \theta \cos 30^\circ - \sin \theta \sin 30^\circ = 0.5$ , for  $0 \leq \theta \leq 360^\circ$ .

(b) Hence write down, in the same interval, the solutions of  $\sqrt{3} \cos \theta - \sin \theta = 1$ .

#### Solution:

$$(a) \cos \theta \cos 30^\circ - \sin \theta \sin 30^\circ = 0.5$$

$$\Rightarrow \cos (\theta + 30^\circ) = 0.5$$

$$\Rightarrow \theta + 30^\circ = 60^\circ, 300^\circ$$

$$\Rightarrow \theta = 30^\circ, 270^\circ$$

$$(b) \cos \theta \cos 30^\circ - \sin \theta \sin 30^\circ \equiv \cos \theta \times \frac{\sqrt{3}}{2} - \sin \theta \times \frac{1}{2}$$

$$\text{So } \cos \theta \cos 30^\circ - \sin \theta \sin 30^\circ = \frac{1}{2}$$

is identical to  $\sqrt{3} \cos \theta - \sin \theta = 1$

Solutions are same as (a), i.e.  $30^\circ, 270^\circ$

# Solutionbank

## Edexcel AS and A Level Modular Mathematics

Exercise A, Question 15

### Question:

- (a) Express  $\tan (45 + 30)^\circ$  in terms of  $\tan 45^\circ$  and  $\tan 30^\circ$ .
- (b) Hence show that  $\tan 75^\circ = 2 + \sqrt{3}$ .

### Solution:

$$(a) \tan (45 + 30)^\circ = \frac{\tan 45^\circ + \tan 30^\circ}{1 - \tan 45^\circ \tan 30^\circ}$$

(b)

$$\tan 75^\circ = \frac{1 + \frac{1}{\sqrt{3}}}{1 - \frac{1}{\sqrt{3}}}$$

$$= \frac{\sqrt{3} + 1}{\sqrt{3} - 1}$$

$$= \frac{(\sqrt{3} + 1)(\sqrt{3} + 1)}{(\sqrt{3} - 1)(\sqrt{3} + 1)}$$

$$= \frac{4 + 2\sqrt{3}}{2}$$

$$= 2 + \sqrt{3}$$

© Pearson Education Ltd 2008

# Solutionbank

## Edexcel AS and A Level Modular Mathematics

### Exercise A, Question 16

#### Question:

Show that  $\sec 105^\circ = -\sqrt{2}(1 + \sqrt{3})$

#### Solution:

$$\begin{aligned}\cos(60 + 45)^\circ &= \cos 60^\circ \cos 45^\circ - \sin 60^\circ \sin 45^\circ \\ &= \frac{1}{2} \times \frac{1}{\sqrt{2}} - \frac{\sqrt{3}}{2} \times \frac{1}{\sqrt{2}} \\ &= \frac{1 - \sqrt{3}}{2\sqrt{2}}\end{aligned}$$

$$\begin{aligned}\text{So } \sec 105^\circ &= \frac{1}{\cos 105^\circ} = \frac{2\sqrt{2}}{1 - \sqrt{3}} \\ &= \frac{2\sqrt{2}(1 + \sqrt{3})}{(1 - \sqrt{3})(1 + \sqrt{3})} \\ &= \frac{2\sqrt{2}(1 + \sqrt{3})}{-2} \\ &= -\sqrt{2}(1 + \sqrt{3})\end{aligned}$$

# Solutionbank

## Edexcel AS and A Level Modular Mathematics

### Exercise A, Question 17

#### Question:

Calculate the exact values of

(a)  $\cos 15^\circ$

(b)  $\sin 75^\circ$

(c)  $\sin ( 120 + 45 )^\circ$

(d)  $\tan 165^\circ$

#### Solution:

$$\begin{aligned} \text{(a) } \cos 15^\circ &= \cos ( 45 - 30 )^\circ \\ &= \cos 45^\circ \cos 30^\circ + \sin 45^\circ \sin 30^\circ \\ &= \frac{\sqrt{2}}{2} \times \frac{\sqrt{3}}{2} + \frac{\sqrt{2}}{2} \times \frac{1}{2} \\ &= \frac{\sqrt{2}}{4} ( \sqrt{3} + 1 ) \end{aligned}$$

$$\begin{aligned} \text{(b) } \sin 75^\circ &= \sin ( 45 + 30 )^\circ \\ &= \sin 45^\circ \cos 30^\circ + \cos 45^\circ \sin 30^\circ \\ &= \frac{\sqrt{2}}{2} \times \frac{\sqrt{3}}{2} + \frac{\sqrt{2}}{2} \times \frac{1}{2} \\ &= \frac{\sqrt{2}}{4} ( \sqrt{3} + 1 ) \end{aligned}$$

$$[ \sin 75^\circ = \cos ( 90 - 75^\circ ) = \cos 15^\circ ]$$

$$\begin{aligned} \text{(c) } \sin ( 120 + 45 )^\circ &= \sin 120^\circ \cos 45^\circ + \cos 120^\circ \sin 45^\circ \\ &= \frac{\sqrt{3}}{2} \times \frac{\sqrt{2}}{2} + \left( -\frac{1}{2} \right) \frac{\sqrt{2}}{2} \\ &= \frac{\sqrt{2}}{4} ( \sqrt{3} - 1 ) \end{aligned}$$

$$\begin{aligned} \text{(d) } \tan 165^\circ &= \tan ( 120 + 45 )^\circ = \frac{\tan 120^\circ + \tan 45^\circ}{1 - \tan 120^\circ \tan 45^\circ} \quad ( \tan 120^\circ \\ &= -\sqrt{3} ) \end{aligned}$$

$$\begin{aligned} &= \frac{-\sqrt{3}+1}{1+\sqrt{3}} \\ &= \frac{(-\sqrt{3}+1)(\sqrt{3}-1)}{(\sqrt{3}+1)(\sqrt{3}-1)} \\ &= \frac{-4+2\sqrt{3}}{2} \\ &= -2+\sqrt{3} \end{aligned}$$

© Pearson Education Ltd 2008

# Solutionbank

## Edexcel AS and A Level Modular Mathematics

Exercise A, Question 18

### Question:

- (a) Given that  $3 \sin (x - y) - \sin (x + y) = 0$ , show that  $\tan x = 2 \tan y$ .
- (b) Solve  $3 \sin (x - 45^\circ) - \sin (x + 45^\circ) = 0$ , for  $0 \leq x \leq 360^\circ$ .

### Solution:

$$\begin{aligned}
 \text{(a) } & 3 \sin (x - y) - \sin (x + y) = 0 \\
 & \Rightarrow 3 \sin x \cos y - 3 \cos x \sin y - \sin x \cos y - \cos x \sin y = 0 \\
 & \Rightarrow 2 \sin x \cos y = 4 \cos x \sin y \\
 & \Rightarrow \frac{2 \sin x \cos y}{\cos x \cos y} = \frac{4 \cos x \sin y}{\cos x \cos y} \\
 & \Rightarrow \frac{2 \sin x}{\cos x} = \frac{4 \sin y}{\cos y} \\
 & \Rightarrow 2 \tan x = 4 \tan y
 \end{aligned}$$

So  $\tan x = 2 \tan y$

$$\text{(b) Put } y = 45^\circ \Rightarrow \tan x = 2$$

$$\text{So } x = \tan^{-1} 2, 180^\circ + \tan^{-1} 2 = 63.4^\circ, 243.4^\circ$$

# Solutionbank

## Edexcel AS and A Level Modular Mathematics

### Exercise A, Question 19

#### Question:

Given that  $\sin x (\cos y + 2 \sin y) = \cos x (2 \cos y - \sin y)$ , find the value of  $\tan (x + y)$ .

#### Solution:

$$\begin{aligned}\sin x (\cos y + 2 \sin y) &= \cos x (2 \cos y - \sin y) \\ \Rightarrow \sin x \cos y + 2 \sin x \sin y &= 2 \cos x \cos y - \cos x \sin y \\ \Rightarrow \sin x \cos y + \cos x \sin y &= 2 (\cos x \cos y - \sin x \sin y) \\ \Rightarrow \sin (x + y) &= 2 \cos (x + y) \\ \Rightarrow \frac{\sin (x + y)}{\cos (x + y)} &= 2 \\ \Rightarrow \tan (x + y) &= 2\end{aligned}$$



# Solutionbank

## Edexcel AS and A Level Modular Mathematics

Exercise A, Question 20

### Question:

Given that  $\tan (x - y) = 3$ , express  $\tan y$  in terms of  $\tan x$ .

### Solution:

As  $\tan (x - y) = 3$

$$\text{so } \frac{\tan x - \tan y}{1 + \tan x \tan y} = 3$$

$$\Rightarrow \tan x - \tan y = 3 + 3 \tan x \tan y$$

$$\Rightarrow 3 \tan x \tan y + \tan y = \tan x - 3$$

$$\Rightarrow \tan y (3 \tan x + 1) = \tan x - 3$$

$$\Rightarrow \tan y = \frac{\tan x - 3}{3 \tan x + 1}$$

© Pearson Education Ltd 2008

# Solutionbank

## Edexcel AS and A Level Modular Mathematics

### Exercise A, Question 21

#### Question:

In each of the following, calculate the exact value of  $\tan x^\circ$ .

$$(a) \tan (x - 45)^\circ = \frac{1}{4}$$

$$(b) \sin (x - 60)^\circ = 3 \cos (x + 30)^\circ$$

$$(c) \tan (x - 60)^\circ = 2$$

#### Solution:

$$(a) \tan (x - 45)^\circ = \frac{1}{4}$$

$$\Rightarrow \frac{\tan x^\circ - \tan 45^\circ}{1 + \tan x^\circ \tan 45^\circ} = \frac{1}{4}$$

$$\Rightarrow 4 \tan x^\circ - 4 = 1 + \tan x^\circ \quad (\tan 45^\circ = 1)$$

$$\Rightarrow 3 \tan x^\circ = 5$$

$$\Rightarrow \tan x^\circ = \frac{5}{3}$$

$$(b) \sin (x - 60)^\circ = 3 \cos (x + 30)^\circ$$

$$\Rightarrow \sin x^\circ \cos 60^\circ - \cos x^\circ \sin 60^\circ = 3 \cos x^\circ \cos 30^\circ - 3 \sin x^\circ \sin 30^\circ$$

$$\Rightarrow \sin x^\circ \times \frac{1}{2} - \cos x^\circ \times \frac{\sqrt{3}}{2} = 3 \cos x^\circ \times \frac{\sqrt{3}}{2} - 3 \sin x^\circ \times \frac{1}{2}$$

$$\Rightarrow 4 \sin x^\circ = 4 \sqrt{3} \cos x^\circ$$

$$\Rightarrow \frac{\sin x^\circ}{\cos x^\circ} = \frac{4 \sqrt{3}}{4}$$

$$\Rightarrow \tan x^\circ = \sqrt{3}$$

$$(c) \tan (x - 60)^\circ = 2$$

$$\Rightarrow \frac{\tan x^\circ - \tan 60^\circ}{1 + \tan x^\circ \tan 60^\circ} = 2$$

$$\Rightarrow \frac{\tan x^\circ - \sqrt{3}}{1 + \sqrt{3} \tan x^\circ} = 2$$

$$\Rightarrow \tan x^\circ - \sqrt{3} = 2 + 2\sqrt{3} \tan x^\circ$$

$$\Rightarrow (2\sqrt{3} - 1) \tan x^\circ = - (2 + \sqrt{3})$$

$$\Rightarrow \tan x^\circ = - \frac{(2 + \sqrt{3})}{2\sqrt{3} - 1} = - \frac{(2 + \sqrt{3})(2\sqrt{3} + 1)}{(2\sqrt{3} - 1)(2\sqrt{3} + 1)} = - \frac{8 + 5\sqrt{3}}{11}$$

# Solutionbank

## Edexcel AS and A Level Modular Mathematics

Exercise A, Question 22

### Question:

Given that  $\tan A^\circ = \frac{1}{5}$  and  $\tan B^\circ = \frac{2}{3}$ , calculate, without using your calculator, the value of  $A + B$ ,

- (a) where  $A$  and  $B$  are both acute,  
 (b) where  $A$  is reflex and  $B$  is acute.

### Solution:

$$(a) \tan (A^\circ + B^\circ) = \frac{\tan A^\circ + \tan B^\circ}{1 - \tan A^\circ \tan B^\circ}$$

$$= \frac{\frac{1}{5} + \frac{2}{3}}{1 - \frac{1}{5} \times \frac{2}{3}} = \frac{\frac{13}{15}}{\frac{15-2}{15}} = \frac{13}{15} = 1$$

As  $\tan (A + B)^\circ$  is +ve,  $A + B$  is in the 1st or 3rd quadrants, but as they are both acute  $A + B$  cannot be in the 3rd quadrant.

So  $(A + B)^\circ = \tan^{-1} 1 = 45^\circ$   
 i.e.  $A + B = 45$

(b)  $A$  is reflex but  $\tan A^\circ$  is +ve, so  $A$  is in 3rd quadrant,  
 i.e.  $180^\circ < A^\circ < 270^\circ$   
 and  $0^\circ < B^\circ < 90^\circ$

$(A + B)^\circ$  must be in the 3rd quadrant as  $\tan (A + B)^\circ$  is +ve.  
 So  $A + B = 225$

# Solutionbank

## Edexcel AS and A Level Modular Mathematics

Exercise A, Question 23

### Question:

Given that  $\cos y = \sin ( x + y )$  , show that  $\tan y = \sec x - \tan x$ .

### Solution:

$$\cos y = \sin ( x + y )$$

$$\Rightarrow \cos y = \sin x \cos y + \cos x \sin y$$

Divide throughout by  $\cos x \cos y$

$$\frac{\cancel{\cos y}^1}{\cos x \cancel{\cos y}} = \frac{\sin x \cancel{\cos y}}{\cos x \cancel{\cos y}} + \frac{\cancel{\cos x} \sin y}{\cancel{\cos x} \cos y}$$

$$\Rightarrow \sec x = \tan x + \tan y$$

$$\Rightarrow \tan y = \sec x - \tan x$$

© Pearson Education Ltd 2008

# Solutionbank

## Edexcel AS and A Level Modular Mathematics

Exercise A, Question 24

### Question:

Given that  $\cot A = \frac{1}{4}$  and  $\cot (A + B) = 2$ , find the value of  $\cot B$ .

### Solution:

$$\cot (A + B) = 2$$

$$\Rightarrow \tan (A + B) = \frac{1}{2}$$

$$\Rightarrow \frac{\tan A + \tan B}{1 - \tan A \tan B} = \frac{1}{2}$$

But as  $\cot A = \frac{1}{4}$ , then  $\tan A = 4$ .

$$\text{So } \frac{4 + \tan B}{1 - 4 \tan B} = \frac{1}{2}$$

$$\Rightarrow 8 + 2 \tan B = 1 - 4 \tan B$$

$$\Rightarrow 6 \tan B = -7$$

$$\Rightarrow \tan B = -\frac{7}{6}$$

$$\text{So } \cot B = \frac{1}{\tan B} = -\frac{6}{7}$$

# Solutionbank

## Edexcel AS and A Level Modular Mathematics

Exercise A, Question 25

### Question:

Given that  $\tan \left( x + \frac{\pi}{3} \right) = \frac{1}{2}$ , show that  $\tan x = 8 - 5\sqrt{3}$ .

### Solution:

$$\tan \left( x + \frac{\pi}{3} \right) = \frac{1}{2}$$

$$\Rightarrow \frac{\tan x + \tan \frac{\pi}{3}}{1 - \tan x \tan \frac{\pi}{3}} = \frac{1}{2}$$

$$\Rightarrow \frac{\tan x + \sqrt{3}}{1 - \sqrt{3} \tan x} = \frac{1}{2} \quad \left( \tan \frac{\pi}{3} = \sqrt{3} \right)$$

$$\Rightarrow 2 \tan x + 2\sqrt{3} = 1 - \sqrt{3} \tan x$$

$$\Rightarrow (2 + \sqrt{3}) \tan x = 1 - 2\sqrt{3}$$

$$\Rightarrow \tan x = \frac{1 - 2\sqrt{3}}{2 + \sqrt{3}} = \frac{(1 - 2\sqrt{3})(2 - \sqrt{3})}{(2 + \sqrt{3})(2 - \sqrt{3})} = \frac{2 - 4\sqrt{3} - \sqrt{3} + 6}{1} = 8 - 5\sqrt{3}$$

# Solutionbank

## Edexcel AS and A Level Modular Mathematics

### Exercise B, Question 1

#### Question:

Write the following expressions as a single trigonometric ratio:

(a)  $2 \sin 10^\circ \cos 10^\circ$

(b)  $1 - 2 \sin^2 25^\circ$

(c)  $\cos^2 40^\circ - \sin^2 40^\circ$

(d)  $\frac{2 \tan 5^\circ}{1 - \tan^2 5^\circ}$

(e)  $\frac{1}{2 \sin \left( 24 \frac{1}{2} \right)^\circ \cos \left( 24 \frac{1}{2} \right)^\circ}$

(f)  $6 \cos^2 30^\circ - 3$

(g)  $\frac{\sin 8^\circ}{\sec 8^\circ}$

(h)  $\cos^2 \frac{\pi}{16} - \sin^2 \frac{\pi}{16}$

#### Solution:

(a)  $2 \sin 10^\circ \cos 10^\circ = \sin 20^\circ$  (using  $2 \sin A \cos A \equiv \sin 2A$ )

(b)  $1 - 2 \sin^2 25^\circ = \cos 50^\circ$  (using  $\cos 2A \equiv 1 - 2 \sin^2 A$ )

(c)  $\cos^2 40^\circ - \sin^2 40^\circ = \cos 80^\circ$  (using  $\cos 2A \equiv \cos^2 A - \sin^2 A$ )

(d)  $\frac{2 \tan 5^\circ}{1 - \tan^2 5^\circ} = \tan 10^\circ$  (using  $\tan 2A \equiv \frac{2 \tan A}{1 - \tan^2 A}$ )



$$(e) \frac{1}{2 \sin \left( 24 \frac{1}{2} \right)^\circ \cos \left( 24 \frac{1}{2} \right)^\circ} = \frac{1}{\sin 49^\circ} = \operatorname{cosec} 49^\circ$$

$$(f) 6 \cos^2 30^\circ - 3 = 3 ( 2 \cos^2 30^\circ - 1 ) = 3 \cos 60^\circ$$

$$(g) \frac{\sin 8^\circ}{\sec 8^\circ} = \sin 8^\circ \cos 8^\circ = \frac{1}{2} ( 2 \sin 8^\circ \cos 8^\circ ) = \frac{1}{2} \sin 16^\circ$$

$$(h) \cos^2 \frac{\pi}{16} - \sin^2 \frac{\pi}{16} = \cos \frac{2\pi}{16} = \cos \frac{\pi}{8}$$

© Pearson Education Ltd 2008

# Solutionbank

## Edexcel AS and A Level Modular Mathematics

### Exercise B, Question 2

#### Question:

Without using your calculator find the exact values of:

(a)  $2 \sin \left( 22 \frac{1}{2} \right)^\circ \cos \left( 22 \frac{1}{2} \right)^\circ$

(b)  $2 \cos^2 15^\circ - 1$

(c)  $(\sin 75^\circ - \cos 75^\circ)^2$

(d)  $\frac{2 \tan \frac{\pi}{8}}{1 - \tan^2 \frac{\pi}{8}}$

#### Solution:

(a)  $2 \sin \left( 22 \frac{1}{2} \right)^\circ \cos \left( 22 \frac{1}{2} \right)^\circ = \sin 2 \times 22 \frac{1}{2}^\circ = \sin 45^\circ = \frac{\sqrt{2}}{2}$

(b)  $2 \cos^2 15^\circ - 1 = \cos (2 \times 15^\circ) = \cos 30^\circ = \frac{\sqrt{3}}{2}$

(c)  $(\sin 75^\circ - \cos 75^\circ)^2 = \sin^2 75^\circ + \cos^2 75^\circ - 2 \sin 75^\circ \cos 75^\circ$   
 $= 1 - \sin (2 \times 75^\circ) \quad (\sin^2 75^\circ + \cos^2 75^\circ = 1)$   
 $= 1 - \sin 150^\circ$   
 $= 1 - \frac{1}{2}$   
 $= \frac{1}{2}$

(d)  $\frac{2 \tan \frac{\pi}{8}}{1 - \tan^2 \frac{\pi}{8}} = \tan \left( 2 \times \frac{\pi}{8} \right) = \tan \frac{\pi}{4} = 1$

# Solutionbank

## Edexcel AS and A Level Modular Mathematics

### Exercise B, Question 3

#### Question:

Write the following in their simplest form, involving only one trigonometric function:

(a)  $\cos^2 3\theta - \sin^2 3\theta$

(b)  $6 \sin 2\theta \cos 2\theta$

(c)  $\frac{2 \tan \frac{\theta}{2}}{1 - \tan^2 \frac{\theta}{2}}$

(d)  $2 - 4 \sin^2 \frac{\theta}{2}$

(e)  $\sqrt{1 + \cos 2\theta}$

(f)  $\sin^2 \theta \cos^2 \theta$

(g)  $4 \sin \theta \cos \theta \cos 2\theta$

(h)  $\frac{\tan \theta}{\sec^2 \theta - 2}$

(i)  $\sin^4 \theta - 2 \sin^2 \theta \cos^2 \theta + \cos^4 \theta$

#### Solution:

(a)  $\cos^2 3\theta - \sin^2 3\theta = \cos (2 \times 3\theta) = \cos 6\theta$

(b)  $6 \sin 2\theta \cos 2\theta = 3 (2 \sin 2\theta \cos 2\theta) = 3 \sin (2 \times 2\theta) = 3 \sin 4\theta$

(c)  $\frac{2 \tan \frac{\theta}{2}}{1 - \tan^2 \frac{\theta}{2}} = \tan \left( 2 \times \frac{\theta}{2} \right) = \tan \theta$

$$\begin{aligned} \text{(d)} \quad 2 - 4 \sin^2 \left( \frac{1}{2} \theta \right) &= 2 \left[ 1 - 2 \sin^2 \left( \frac{1}{2} \theta \right) \right] = 2 \cos \left( 2 \times \frac{1}{2} \theta \right) \\ &= 2 \cos \theta \end{aligned}$$

$$\text{(e)} \quad \sqrt{1 + \cos 2\theta} = \sqrt{1 + (2 \cos^2 \theta - 1)} = \sqrt{2 \cos^2 \theta} = \sqrt{2} \cos \theta$$

$$\text{(f)} \quad \sin^2 \theta \cos^2 \theta = \frac{1}{4} (4 \sin^2 \theta \cos^2 \theta) = \frac{1}{4} (2 \sin \theta \cos \theta)^2 = \frac{1}{4} \sin^2 2\theta$$

$$\begin{aligned} \text{(g)} \quad 4 \sin \theta \cos \theta \cos 2\theta &= 2 (2 \sin \theta \cos \theta) \cos 2\theta \\ &= 2 \sin 2\theta \cos 2\theta \\ &= \sin 4\theta \quad (\sin 2A = 2 \sin A \cos A \text{ with } A = 2\theta) \end{aligned}$$

$$\begin{aligned} \text{(h)} \quad \frac{\tan \theta}{\sec^2 \theta - 2} &= \frac{\tan \theta}{(1 + \tan^2 \theta) - 2} \\ &= \frac{\tan \theta}{\tan^2 \theta - 1} \\ &= - \frac{\tan \theta}{1 - \tan^2 \theta} \\ &= - \frac{1}{2} \left( \frac{2 \tan \theta}{1 - \tan^2 \theta} \right) \\ &= - \frac{1}{2} \tan 2\theta \end{aligned}$$

$$\text{(i)} \quad \cos^4 \theta - 2 \sin^2 \theta \cos^2 \theta + \sin^4 \theta = (\cos^2 \theta - \sin^2 \theta)^2 = \cos^2 2\theta$$

# Solutionbank

## Edexcel AS and A Level Modular Mathematics

Exercise B, Question 4

### Question:

Given that  $\cos x = \frac{1}{4}$ , find the exact value of  $\cos 2x$ .

### Solution:

$$\cos 2x = 2 \cos^2 x - 1 = 2 \left( \frac{1}{4} \right)^2 - 1 = \frac{1}{8} - 1 = -\frac{7}{8}$$

© Pearson Education Ltd 2008

# Solutionbank

## Edexcel AS and A Level Modular Mathematics

### Exercise B, Question 5

#### Question:

Find the possible values of  $\sin \theta$  when  $\cos 2\theta = \frac{23}{25}$ .

#### Solution:

$$\cos 2\theta = 1 - 2\sin^2 \theta$$

$$\text{So } \frac{23}{25} = 1 - 2\sin^2 \theta$$

$$\Rightarrow 2\sin^2 \theta = 1 - \frac{23}{25} = \frac{2}{25}$$

$$\Rightarrow \sin^2 \theta = \frac{1}{25}$$

$$\Rightarrow \sin \theta = \pm \frac{1}{5}$$

# Solutionbank

## Edexcel AS and A Level Modular Mathematics

Exercise B, Question 6

### Question:

Given that  $\cos x + \sin x = m$  and  $\cos x - \sin x = n$ , where  $m$  and  $n$  are constants, write down, in terms of  $m$  and  $n$ , the value of  $\cos 2x$ .

### Solution:

$$\cos x + \sin x = m$$

$$\cos x - \sin x = n$$

Multiply the equations:

$$(\cos x + \sin x)(\cos x - \sin x) = mn$$

$$\Rightarrow \cos^2 x - \sin^2 x = mn$$

$$\Rightarrow \cos 2x = mn$$

© Pearson Education Ltd 2008

# Solutionbank

## Edexcel AS and A Level Modular Mathematics

### Exercise B, Question 7

#### Question:

Given that  $\tan \theta = \frac{3}{4}$ , and that  $\theta$  is acute:

(a) Find the exact value of

(i)  $\tan 2\theta$

(ii)  $\sin 2\theta$

(iii)  $\cos 2\theta$

(b) Deduce the value of  $\sin 4\theta$ .

#### Solution:

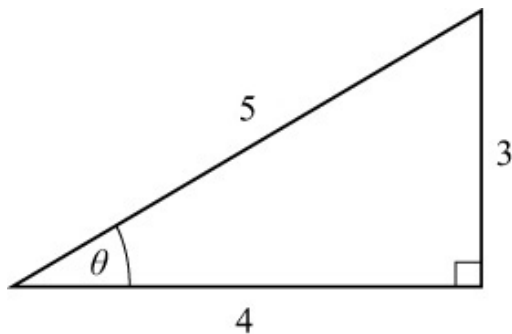

The hypotenuse is 5,

so  $\sin \theta = \frac{3}{5}$ ,  $\cos \theta = \frac{4}{5}$ ,  $\tan \theta = \frac{3}{4}$

$$(a) (i) \tan 2\theta = \frac{2 \tan \theta}{1 - \tan^2 \theta} = \frac{\frac{3}{2}}{1 - \frac{9}{16}} = \frac{\frac{3}{2}}{\frac{7}{16}} = \frac{3}{2} \times \frac{16}{7} = \frac{24}{7}$$

$$(ii) \sin 2\theta = 2 \sin \theta \cos \theta = 2 \times \frac{3}{5} \times \frac{4}{5} = \frac{24}{25}$$

$$(iii) \cos 2\theta = \cos^2 \theta - \sin^2 \theta = \frac{16}{25} - \frac{9}{25} = \frac{7}{25}$$

$$(b) \sin 4\theta = 2 \sin 2\theta \cos 2\theta = 2 \times \frac{24}{25} \times \frac{7}{25} = \frac{336}{625}$$



# Solutionbank

## Edexcel AS and A Level Modular Mathematics

### Exercise B, Question 8

#### Question:

Given that  $\cos A = -\frac{1}{3}$ , and that  $A$  is obtuse:

(a) Find the exact value of

(i)  $\cos 2A$

(ii)  $\sin A$

(iii)  $\operatorname{cosec} 2A$

(b) Show that  $\tan 2A = \frac{4\sqrt{2}}{7}$ .

#### Solution:

$$(a) (i) \cos 2A = 2 \cos^2 A - 1 = 2 \left( -\frac{1}{3} \right)^2 - 1 = \frac{2}{9} - 1 = -\frac{7}{9}$$

$$(ii) \cos 2A = 1 - 2 \sin^2 A$$

$$\Rightarrow -\frac{7}{9} = 1 - 2 \sin^2 A$$

$$\Rightarrow 2 \sin^2 A = 1 + \frac{7}{9} = \frac{16}{9}$$

$$\Rightarrow \sin^2 A = \frac{8}{9}$$

$$\Rightarrow \sin A = \pm \frac{2\sqrt{2}}{3} \quad (\sqrt{8} = 2\sqrt{2})$$

but  $A$  is in 2nd quadrant  $\Rightarrow \sin A$  is +ve.

$$\text{So } \sin A = \frac{2\sqrt{2}}{3}$$

$$(iii) \operatorname{cosec} 2A = \frac{1}{\sin 2A} = \frac{1}{2 \sin A \cos A} = \frac{1}{2 \times \frac{2\sqrt{2}}{3} \times \left( -\frac{1}{3} \right)} = -\frac{9}{4\sqrt{2}} = -\frac{9\sqrt{2}}{8}$$

$$(b) \tan 2A = \frac{\sin 2A}{\cos 2A} = \frac{-\frac{4\sqrt{2}}{9}}{-\frac{7}{9}} = \frac{-4\sqrt{2}}{9} \times \frac{-9}{7} = \frac{4\sqrt{2}}{7}$$

© Pearson Education Ltd 2008

# Solutionbank

## Edexcel AS and A Level Modular Mathematics

Exercise B, Question 9

### Question:

Given that  $\pi < \theta < \frac{3\pi}{2}$ , find the value of  $\tan \frac{\theta}{2}$  when  $\tan \theta = \frac{3}{4}$ .

### Solution:

$$\text{Using } \tan \theta = \frac{2 \tan \frac{\theta}{2}}{1 - \tan^2 \frac{\theta}{2}}$$

$$\Rightarrow \frac{3}{4} = \frac{2 \tan \frac{\theta}{2}}{1 - \tan^2 \frac{\theta}{2}}$$

$$\Rightarrow 3 - 3 \tan^2 \frac{\theta}{2} = 8 \tan \frac{\theta}{2}$$

$$\Rightarrow 3 \tan^2 \frac{\theta}{2} + 8 \tan \frac{\theta}{2} - 3 = 0$$

$$\Rightarrow \left( 3 \tan \frac{\theta}{2} - 1 \right) \left( \tan \frac{\theta}{2} + 3 \right) = 0$$

$$\text{so } \tan \frac{\theta}{2} = \frac{1}{3} \text{ or } \tan \frac{\theta}{2} = -3$$

$$\text{but } \pi < \theta < \frac{3\pi}{2}$$

$$\text{so } \frac{\pi}{2} < \frac{\theta}{2} < \frac{3\pi}{4}$$

i.e.  $\frac{\theta}{2}$  is in the 2nd quadrant

So  $\tan \frac{\theta}{2}$  is -ve.

$$\Rightarrow \tan \frac{\theta}{2} = -3$$

# Solutionbank

## Edexcel AS and A Level Modular Mathematics

### Exercise B, Question 10

#### Question:

In  $\triangle ABC$ ,  $AB = 4$  cm,  $AC = 5$  cm,  $\angle ABC = 2\theta$  and  $\angle ACB = \theta$ . Find the value of  $\theta$ , giving your answer, in degrees, to 1 decimal place.

#### Solution:

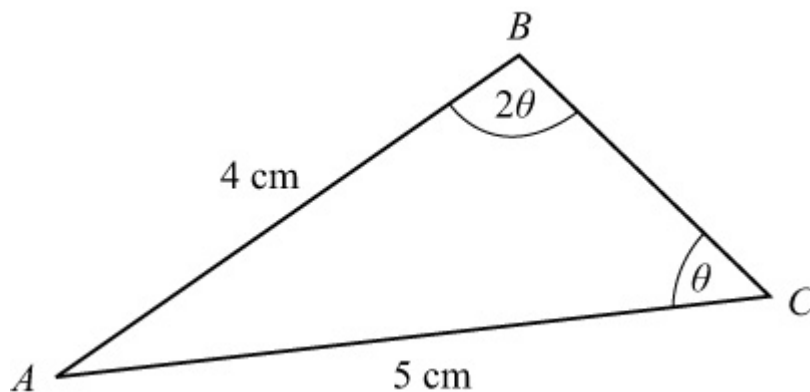

Using sine rule with  $\frac{\sin B}{b} = \frac{\sin C}{c}$

$$\Rightarrow \frac{\sin 2\theta}{5} = \frac{\sin \theta}{4}$$

$$\Rightarrow \frac{2 \sin \theta \cos \theta}{5} = \frac{\sin \theta}{4}$$

Cancel  $\sin \theta$  as  $\theta \neq 0^\circ$  or  $180^\circ$

$$\text{So } 2 \cos \theta = \frac{5}{4}$$

$$\Rightarrow \cos \theta = \frac{5}{8}$$

$$\text{So } \theta = \cos^{-1} \frac{5}{8} = 51.3^\circ$$

# Solutionbank

## Edexcel AS and A Level Modular Mathematics

### Exercise B, Question 11

#### Question:

In  $\triangle PQR$ ,  $PQ = 3$  cm,  $PR = 6$  cm,  $QR = 5$  cm and  $\angle QPR = 2\theta$ .

(a) Use the cosine rule to show that  $\cos 2\theta = \frac{5}{9}$ .

(b) Hence find the exact value of  $\sin \theta$ .

#### Solution:

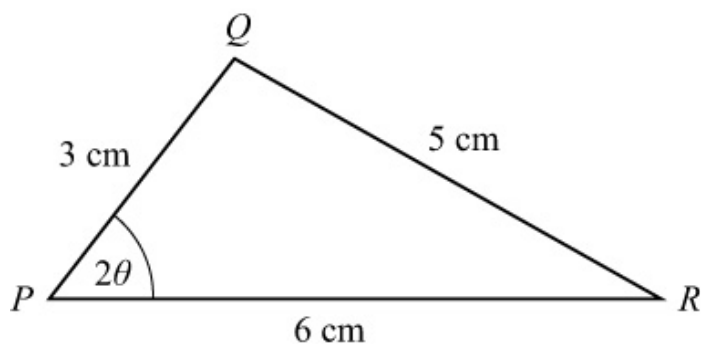

(a) Using cosine rule with  $\cos P = \frac{q^2 + r^2 - p^2}{2qr}$

$$\cos 2\theta = \frac{36 + 9 - 25}{2 \times 6 \times 3} = \frac{20}{36} = \frac{5}{9}$$

(b) Using  $\cos 2\theta = 1 - 2\sin^2 \theta$

$$\frac{5}{9} = 1 - 2\sin^2 \theta$$

$$\Rightarrow 2\sin^2 \theta = 1 - \frac{5}{9} = \frac{4}{9}$$

$$\Rightarrow \sin^2 \theta = \frac{2}{9}$$

$$\Rightarrow \sin \theta = \pm \frac{\sqrt{2}}{3}$$

but  $\sin \theta$  cannot be negative for  $\theta$  in a triangle

$$\text{so } \sin \theta = \frac{\sqrt{2}}{3}$$

# Solutionbank

## Edexcel AS and A Level Modular Mathematics

### Exercise B, Question 12

#### Question:

The line  $l$ , with equation  $y = \frac{3}{4}x$ , bisects the angle between the  $x$ -axis and the line  $y = mx$ ,  $m > 0$ . Given that the scales on each axis are the same, and that  $l$  makes an angle  $\theta$  with the  $x$ -axis,

(a) write down the value of  $\tan \theta$ .

(b) Show that  $m = \frac{24}{7}$ .

#### Solution:

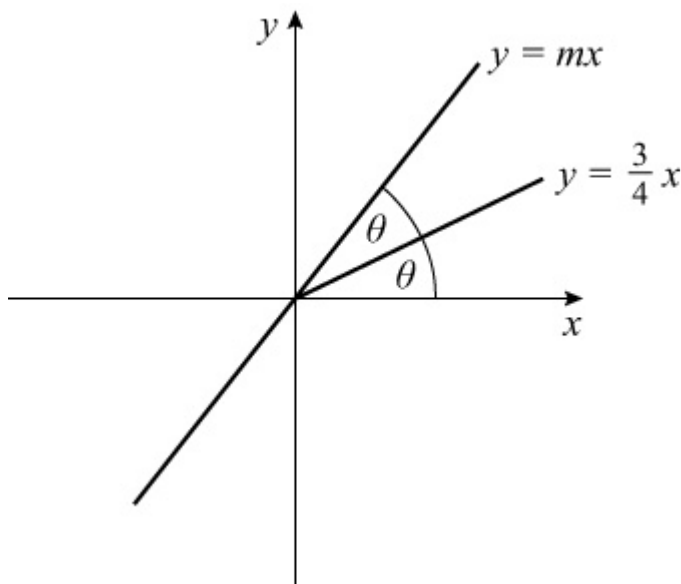

(a) The gradient of line  $l$  is  $\frac{3}{4}$ , which is  $\tan \theta$ .

$$\text{So } \tan \theta = \frac{3}{4}$$

(b) The gradient of  $y = mx$  is  $m$ , and as  $y = \frac{3}{4}x$  bisects the angle between  $y = mx$  and  $x$ -axis

$$m = \tan 2\theta = \frac{2 \tan \theta}{1 - \tan^2 \theta} = \frac{2 \times \frac{3}{4}}{1 - \left(\frac{3}{4}\right)^2} = \frac{\frac{3}{2}}{\frac{7}{16}} = \frac{3}{2} \times \frac{16}{7} = \frac{24}{7}$$

© Pearson Education Ltd 2008

# Solutionbank

## Edexcel AS and A Level Modular Mathematics

### Exercise C, Question 1

#### Question:

Prove the following identities:

$$(a) \frac{\cos 2A}{\cos A + \sin A} \equiv \cos A - \sin A$$

$$(b) \frac{\sin B}{\sin A} - \frac{\cos B}{\cos A} \equiv 2 \operatorname{cosec} 2A \sin (B - A)$$

$$(c) \frac{1 - \cos 2\theta}{\sin 2\theta} \equiv \tan \theta$$

$$(d) \frac{\sec^2 \theta}{1 - \tan^2 \theta} \equiv \sec 2\theta$$

$$(e) 2 (\sin^3 \theta \cos \theta + \cos^3 \theta \sin \theta) \equiv \sin 2\theta$$

$$(f) \frac{\sin 3\theta}{\sin \theta} - \frac{\cos 3\theta}{\cos \theta} \equiv 2$$

$$(g) \operatorname{cosec} \theta - 2 \cot 2\theta \cos \theta \equiv 2 \sin \theta$$

$$(h) \frac{\sec \theta - 1}{\sec \theta + 1} \equiv \tan^2 \frac{\theta}{2}$$

$$(i) \tan \left( \frac{\pi}{4} - x \right) \equiv \frac{1 - \sin 2x}{\cos 2x}$$

#### Solution:

$$\begin{aligned} (a) \text{ L.H.S.} &\equiv \frac{\cos 2A}{\cos A + \sin A} \\ &\equiv \frac{\cos^2 A - \sin^2 A}{\cos A + \sin A} \\ &\equiv \frac{(\cos A + \sin A)(\cos A - \sin A)}{\cos A + \sin A} \\ &\equiv \cos A - \sin A \equiv \text{R.H.S.} \end{aligned}$$

$$\begin{aligned} (b) \text{ L.H.S.} &\equiv \frac{\sin B}{\sin A} - \frac{\cos B}{\cos A} \\ &\equiv \frac{\sin B \cos A - \cos B \sin A}{\sin A \cos A} \end{aligned}$$



$$\begin{aligned}
&\equiv \frac{\sin(B-A)}{\frac{1}{2}(2\sin A \cos A)} \\
&\equiv \frac{2\sin(B-A)}{\sin 2A} \\
&\equiv 2 \operatorname{cosec} 2A \sin(B-A) \equiv \text{R.H.S.}
\end{aligned}$$

$$\begin{aligned}
\text{(c) L.H.S.} &\equiv \frac{1 - \cos 2\theta}{\sin 2\theta} \\
&\equiv \frac{1 - (1 - 2\sin^2 \theta)}{2\sin \theta \cos \theta} \\
&\equiv \frac{2\sin^2 \theta}{2\sin \theta \cos \theta} \\
&\equiv \frac{\sin \theta}{\cos \theta} \\
&\equiv \tan \theta \equiv \text{R.H.S.}
\end{aligned}$$

$$\begin{aligned}
\text{(d) L.H.S.} &\equiv \frac{\sec^2 \theta}{1 - \tan^2 \theta} \\
&\equiv \frac{1}{\cos^2 \theta (1 - \tan^2 \theta)} \\
&\equiv \frac{1}{\cos^2 \theta - \sin^2 \theta} \quad \left(\text{as } \tan^2 \theta = \frac{\sin^2 \theta}{\cos^2 \theta}\right) \\
&\equiv \frac{1}{\cos 2\theta} \\
&\equiv \sec 2\theta \equiv \text{R.H.S.}
\end{aligned}$$

$$\begin{aligned}
\text{(e) L.H.S.} &\equiv 2(\sin^3 \theta \cos \theta + \cos^3 \theta \sin \theta) \\
&\equiv 2\sin \theta \cos \theta (\sin^2 \theta + \cos^2 \theta) \\
&\equiv \sin 2\theta \quad (\text{since } \sin^2 \theta + \cos^2 \theta \equiv 1) \\
&\equiv \text{R.H.S.}
\end{aligned}$$

$$\begin{aligned}
\text{(f) L.H.S.} &\equiv \frac{\sin 3\theta}{\sin \theta} - \frac{\cos 3\theta}{\cos \theta} \\
&\equiv \frac{\sin 3\theta \cos \theta - \cos 3\theta \sin \theta}{\sin \theta \cos \theta} \\
&\equiv \frac{\sin(3\theta - \theta)}{\frac{1}{2}\sin 2\theta}
\end{aligned}$$

$$\begin{aligned} &\equiv \frac{\sin 2\theta}{\frac{1}{2} \sin 2\theta} \\ &\equiv 2 \equiv \text{R.H.S.} \end{aligned}$$

(g) L.H.S.  $\equiv \operatorname{cosec} \theta - 2 \cot 2\theta \cos \theta$

$$\begin{aligned} &\equiv \operatorname{cosec} \theta - 2 \frac{\cos 2\theta}{\sin 2\theta} \cos \theta \\ &\equiv \operatorname{cosec} \theta - \frac{2 \cos 2\theta \cos \theta}{2 \sin \theta \cos \theta} \\ &\equiv \frac{1}{\sin \theta} - \frac{\cos 2\theta}{\sin \theta} \\ &\equiv \frac{1 - \cos 2\theta}{\sin \theta} \\ &\equiv \frac{1 - (1 - 2\sin^2 \theta)}{\sin \theta} \\ &\equiv \frac{2\sin^2 \theta}{\sin \theta} \\ &\equiv 2 \sin \theta \equiv \text{R.H.S.} \end{aligned}$$

(h)

$$\begin{aligned} \text{L.H.S.} &\equiv \frac{\sec \theta - 1}{\sec \theta + 1} \\ &\equiv \frac{\frac{1}{\cos \theta} - 1}{\frac{1}{\cos \theta} + 1} \\ &\equiv \frac{1 - \cos \theta}{1 + \cos \theta} \\ &\equiv \frac{1 - \left(1 - 2\sin^2 \frac{\theta}{2}\right)}{1 + \left(2\cos^2 \frac{\theta}{2} - 1\right)} \\ &\equiv \frac{2\sin^2 \frac{\theta}{2}}{2\cos^2 \frac{\theta}{2}} \\ &\equiv \tan^2 \frac{\theta}{2} \equiv \text{R.H.S.} \end{aligned}$$

(i)

$$\begin{aligned}
 \text{L.H.S.} &\equiv \tan\left(\frac{\pi}{4} - x\right) \\
 &\equiv \frac{\tan\frac{\pi}{4} - \tan x}{1 + \tan\frac{\pi}{4} \tan x} \\
 &\equiv \frac{1 - \tan x}{1 + \tan x} \\
 &\equiv \frac{1 - \frac{\sin x}{\cos x}}{1 + \frac{\sin x}{\cos x}} \\
 &\equiv \frac{\cos x - \sin x}{\cos x + \sin x}
 \end{aligned}$$

Multiply 'top and bottom' by  $\cos x - \sin x$

$$\begin{aligned}
 &\equiv \frac{\cos^2 x + \sin^2 x - 2 \sin x \cos x}{\cos^2 x - \sin^2 x} \\
 &\equiv \frac{1 - \sin 2x}{\cos 2x} \equiv \text{R.H.S.}
 \end{aligned}$$

# Solutionbank

## Edexcel AS and A Level Modular Mathematics

### Exercise C, Question 2

#### Question:

- (a) Show that  $\tan \theta + \cot \theta \equiv 2 \operatorname{cosec} 2\theta$ .
- (b) Hence find the value of  $\tan 75^\circ + \cot 75^\circ$ .

#### Solution:

$$\begin{aligned}
 \text{(a) L.H.S.} &\equiv \tan \theta + \cot \theta \\
 &\equiv \frac{\sin \theta}{\cos \theta} + \frac{\cos \theta}{\sin \theta} \\
 &\equiv \frac{\sin^2 \theta + \cos^2 \theta}{\sin \theta \cos \theta} \\
 &\equiv \frac{2}{2 \sin \theta \cos \theta} \quad (\sin^2 \theta + \cos^2 \theta \equiv 1) \\
 &\equiv \frac{2}{\sin 2\theta} \\
 &\equiv 2 \operatorname{cosec} 2\theta \equiv \text{R.H.S.}
 \end{aligned}$$

- (b) Use  $\theta = 75^\circ$

$$\Rightarrow \tan 75^\circ + \cot 75^\circ = 2 \operatorname{cosec} 150^\circ = 2 \times \frac{1}{\sin 150^\circ} = 2 \times \frac{1}{\frac{1}{2}} = 4$$

# Solutionbank

## Edexcel AS and A Level Modular Mathematics

### Exercise C, Question 3

#### Question:

Solve the following equations, in the interval shown in brackets. Give answers to 1 decimal place where appropriate.

(a)  $\sin 2\theta = \sin \theta \quad \{ 0 \leq \theta \leq 2\pi \}$

(b)  $\cos 2\theta = 1 - \cos \theta \quad \{ -180^\circ < \theta \leq 180^\circ \}$

(c)  $3 \cos 2\theta = 2 \cos^2 \theta \quad \{ 0 \leq \theta < 360^\circ \}$

(d)  $\sin 4\theta = \cos 2\theta \quad \{ 0 \leq \theta \leq \pi \}$

(e)  $2 \tan 2y \tan y = 3 \quad \{ 0 \leq y < 360^\circ \}$

(f)  $3 \cos \theta - \sin \frac{\theta}{2} - 1 = 0 \quad \left\{ 0 \leq \theta < 720^\circ \right\}$

(g)  $\cos^2 \theta - \sin 2\theta = \sin^2 \theta \quad \{ 0 \leq \theta \leq \pi \}$

(h)  $2 \sin \theta = \sec \theta \quad \{ 0 \leq \theta \leq 2\pi \}$

(i)  $2 \sin 2\theta = 3 \tan \theta \quad \{ 0 \leq \theta < 360^\circ \}$

(j)  $2 \tan \theta = \sqrt{3} (1 - \tan \theta) (1 + \tan \theta) \quad \{ 0 \leq \theta \leq 2\pi \}$

(k)  $5 \sin 2\theta + 4 \sin \theta = 0 \quad \{ -180^\circ < \theta \leq 180^\circ \}$

(l)  $\sin^2 \theta = 2 \sin 2\theta \quad \{ -180^\circ < \theta \leq 180^\circ \}$

(m)  $4 \tan \theta = \tan 2\theta \quad \{ 0 \leq \theta < 360^\circ \}$

#### Solution:

(a)  $\sin 2\theta = \sin \theta, 0 \leq \theta \leq 2\pi$

$$\Rightarrow 2 \sin \theta \cos \theta = \sin \theta$$

$$\Rightarrow 2 \sin \theta \cos \theta - \sin \theta = 0$$

$$\Rightarrow \sin \theta (2 \cos \theta - 1) = 0$$

$$\Rightarrow \sin \theta = 0 \text{ or } \cos \theta = \frac{1}{2}$$

Solution set:  $0, \frac{\pi}{3}, \pi, \frac{5\pi}{3}, 2\pi$

$$(b) \cos 2\theta = 1 - \cos \theta, -180^\circ < \theta \leq 180^\circ$$

$$\Rightarrow 2\cos^2 \theta - 1 = 1 - \cos \theta$$

$$\Rightarrow 2\cos^2 \theta + \cos \theta - 2 = 0$$

$$\Rightarrow \cos \theta = \frac{-1 \pm \sqrt{17}}{4}$$

$$\text{As } \frac{-1 - \sqrt{17}}{4} < -1, \cos \theta = \frac{-1 + \sqrt{17}}{4}$$

As  $\cos \theta$  is +ve,  $\theta$  is in 1st and 4th quadrants.

$$\text{Calculator solution is } \cos^{-1} \left( \frac{-1 + \sqrt{17}}{4} \right) = 38.7^\circ.$$

Solutions are  $\pm 38.7^\circ$

$$(c) 3\cos 2\theta = 2\cos^2 \theta, 0 \leq \theta < 360^\circ$$

$$\Rightarrow 3(2\cos^2 \theta - 1) = 2\cos^2 \theta$$

$$\Rightarrow 6\cos^2 \theta - 3 = 2\cos^2 \theta$$

$$\Rightarrow 4\cos^2 \theta = 3$$

$$\Rightarrow \cos^2 \theta = \frac{3}{4}$$

$$\Rightarrow \cos \theta = \pm \frac{\sqrt{3}}{2}$$

$\theta$  will be in all four quadrants.

Solution set:  $30^\circ, 150^\circ, 210^\circ, 330^\circ$

$$(d) \sin 4\theta = \cos 2\theta, 0 \leq \theta \leq \pi$$

$$\Rightarrow 2\sin 2\theta \cos 2\theta = \cos 2\theta$$

$$\Rightarrow \cos 2\theta (2\sin 2\theta - 1) = 0$$

$$\Rightarrow \cos 2\theta = 0 \text{ or } \sin 2\theta = \frac{1}{2}$$

$$\cos 2\theta = 0 \text{ in } 0 \leq 2\theta \leq 2\pi$$

$$\Rightarrow 2\theta = \frac{\pi}{2}, \frac{3\pi}{2} \Rightarrow \theta = \frac{\pi}{4}, \frac{3\pi}{4}$$

$$\sin 2\theta = \frac{1}{2} \text{ in } 0 \leq 2\theta \leq 2\pi$$

$$\Rightarrow 2\theta = \frac{\pi}{6}, \frac{5\pi}{6} \Rightarrow \theta = \frac{\pi}{12}, \frac{5\pi}{12}$$

Solution set:  $\frac{\pi}{12}, \frac{\pi}{4}, \frac{5\pi}{12}, \frac{3\pi}{4}$

(e)  $2 \tan 2y \tan y = 3, 0 \leq y < 360^\circ$

$$\Rightarrow \frac{4 \tan y}{1 - \tan^2 y} \tan y = 3$$

$$\Rightarrow 4 \tan^2 y = 3 - 3 \tan^2 y$$

$$\Rightarrow 7 \tan^2 y = 3$$

$$\Rightarrow \tan^2 y = \frac{3}{7}$$

$$\Rightarrow \tan y = \pm \sqrt{\frac{3}{7}}$$

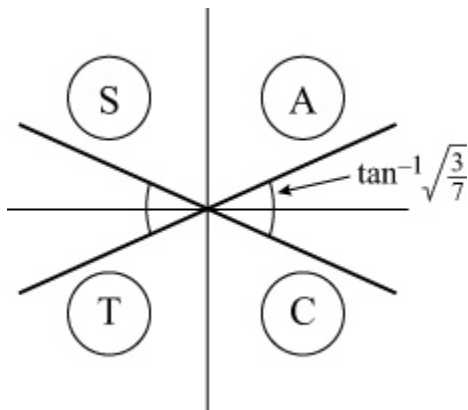

$y$  is in all four quadrants.

$$y = \tan^{-1} \sqrt{\frac{3}{7}}, 180^\circ + \tan^{-1} \left( -\sqrt{\frac{3}{7}} \right), 180^\circ + \tan^{-1} \sqrt{\frac{3}{7}}, 360^\circ$$

$$+ \tan^{-1} \left( -\sqrt{\frac{3}{7}} \right)$$

$$y = 33.2^\circ, 146.8^\circ, 213.2^\circ, 326.8^\circ$$

(f)  $3 \cos \theta - \sin \frac{\theta}{2} - 1 = 0, 0 \leq \theta \leq 720^\circ$

$$\Rightarrow 3 \left( 1 - 2 \sin^2 \frac{\theta}{2} \right) - \sin \frac{\theta}{2} - 1 = 0$$

$$\Rightarrow 6 \sin^2 \frac{\theta}{2} + \sin \frac{\theta}{2} - 2 = 0$$

$$\Rightarrow \left( 3 \sin \frac{\theta}{2} + 2 \right) \left( 2 \sin \frac{\theta}{2} - 1 \right) = 0$$

$$\Rightarrow \sin \frac{\theta}{2} = -\frac{2}{3} \text{ or } \sin \frac{\theta}{2} = \frac{1}{2}$$

$$\sin \frac{\theta}{2} = \frac{1}{2} \text{ in } 0 \leq \frac{\theta}{2} \leq 360^\circ$$

$$\Rightarrow \frac{\theta}{2} = 30^\circ, 150^\circ \Rightarrow \theta = 60^\circ, 300^\circ$$

$$\sin \frac{\theta}{2} = -\frac{2}{3} \text{ in } 0 \leq \frac{\theta}{2} \leq 360^\circ$$

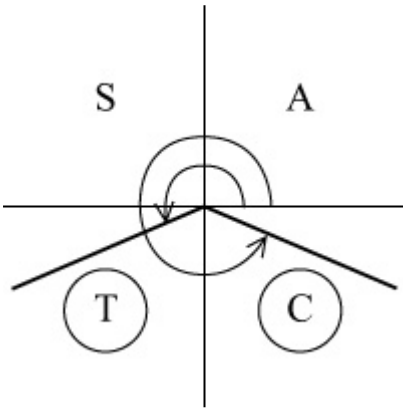

$$\Rightarrow \frac{\theta}{2} = 180^\circ - \sin^{-1} \left( -\frac{2}{3} \right), 360^\circ + \sin^{-1} \left( -\frac{2}{3} \right) = 221.8^\circ,$$

$$318.2^\circ$$

$$\Rightarrow \theta = 443.6^\circ, 636.4^\circ$$

$$\text{Solution set: } 60^\circ, 300^\circ, 443.6^\circ, 636.4^\circ$$

$$(g) \cos^2 \theta - \sin 2\theta = \sin^2 \theta, 0 \leq \theta \leq \pi$$

$$\Rightarrow \cos^2 \theta - \sin^2 \theta = \sin 2\theta$$

$$\Rightarrow \cos 2\theta = \sin 2\theta$$

$$\Rightarrow \tan 2\theta = 1 \quad (\text{divide both sides by } \cos 2\theta)$$

$$\tan 2\theta = 1 \text{ in } 0 \leq 2\theta \leq 2\pi$$

$$\Rightarrow 2\theta = \frac{\pi}{4}, \frac{5\pi}{4}$$

$$\Rightarrow \theta = \frac{\pi}{8}, \frac{5\pi}{8}$$

$$(h) 2 \sin \theta = \sec \theta, 0 \leq \theta \leq 2\pi$$

$$\Rightarrow 2 \sin \theta = \frac{1}{\cos \theta}$$

$$\Rightarrow 2 \sin \theta \cos \theta = 1$$

$$\Rightarrow \sin 2\theta = 1$$



$$\sin 2\theta = 1 \text{ in } 0 \leq 2\theta \leq 4\pi$$

$$\Rightarrow 2\theta = \frac{\pi}{2}, \frac{5\pi}{2} \quad (\text{see graph})$$

$$\Rightarrow \theta = \frac{\pi}{4}, \frac{5\pi}{4}$$

$$(i) 2 \sin 2\theta = 3 \tan \theta, 0 \leq \theta < 360^\circ$$

$$\Rightarrow 4 \sin \theta \cos \theta = \frac{3 \sin \theta}{\cos \theta}$$

$$\Rightarrow 4 \sin \theta \cos^2 \theta = 3 \sin \theta$$

$$\Rightarrow \sin \theta (4 \cos^2 \theta - 3) = 0$$

$$\Rightarrow \sin \theta = 0 \text{ or } \cos^2 \theta = \frac{3}{4}$$

$$\sin \theta = 0 \Rightarrow \theta = 0^\circ, 180^\circ$$

$$\cos^2 \theta = \frac{3}{4} \Rightarrow \cos \theta = \pm \frac{\sqrt{3}}{2} \Rightarrow \theta = 30^\circ, 150^\circ, 210^\circ, 330^\circ$$

Solution set:  $0^\circ, 30^\circ, 150^\circ, 180^\circ, 210^\circ, 330^\circ$

$$(j) 2 \tan \theta = \sqrt{3} (1 - \tan \theta) (1 + \tan \theta), 0 \leq \theta \leq 2\pi$$

$$\Rightarrow 2 \tan \theta = \sqrt{3} (1 - \tan^2 \theta)$$

$$\Rightarrow \sqrt{3} \tan^2 \theta + 2 \tan \theta - \sqrt{3} = 0$$

$$\Rightarrow (\sqrt{3} \tan \theta - 1) (\tan \theta + \sqrt{3}) = 0$$

$$\Rightarrow \tan \theta = \frac{1}{\sqrt{3}} \text{ or } \tan \theta = -\sqrt{3}$$

$$\tan \theta = \frac{1}{\sqrt{3}}, 0 \leq \theta \leq 2\pi$$

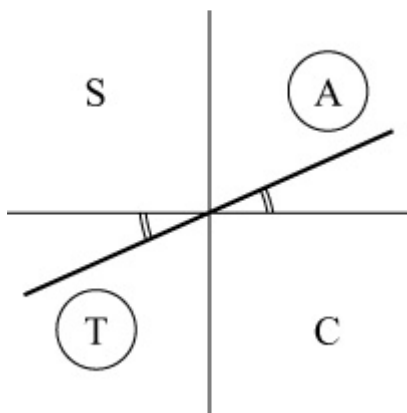

$$\Rightarrow \theta = \tan^{-1} \frac{1}{\sqrt{3}}, \pi + \tan^{-1} \frac{1}{\sqrt{3}} = \frac{\pi}{6}, \frac{7\pi}{6}$$

$$\tan \theta = -\sqrt{3}, 0 \leq \theta \leq 2\pi$$

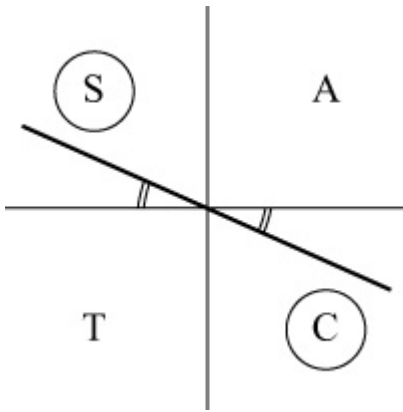

$$\Rightarrow \theta = \pi + \tan^{-1}(-\sqrt{3}), 2\pi + \tan^{-1}(-\sqrt{3}) = \frac{2\pi}{3}, \frac{5\pi}{3}$$

Solution set:  $\frac{\pi}{6}, \frac{2\pi}{3}, \frac{7\pi}{6}, \frac{5\pi}{3}$

(k)  $5 \sin 2\theta + 4 \sin \theta = 0, -180^\circ < \theta \leq 180^\circ$

$$\Rightarrow 10 \sin \theta \cos \theta + 4 \sin \theta = 0$$

$$\Rightarrow 2 \sin \theta (5 \cos \theta + 2) = 0$$

$$\Rightarrow \sin \theta = 0 \text{ or } \cos \theta = -\frac{2}{5}$$

$\sin \theta = 0 \Rightarrow \theta = 0^\circ, 180^\circ$  (from graph)

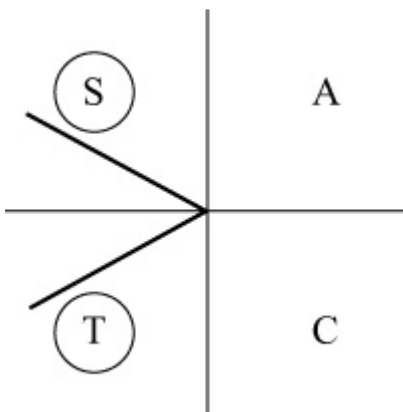

Calculator value for  $\cos^{-1}\left(-\frac{2}{5}\right)$  is  $113.6^\circ$

$$\Rightarrow \theta = \pm 113.6^\circ$$

Solution set:  $-113.6^\circ, 0^\circ, 113.6^\circ, 180^\circ$

(l)  $\sin^2 \theta = 2 \sin 2\theta, -180^\circ < \theta \leq 180^\circ$

$$\Rightarrow \sin^2 \theta = 4 \sin \theta \cos \theta$$

$$\Rightarrow \sin \theta (\sin \theta - 4 \cos \theta) = 0$$

$$\Rightarrow \sin \theta = 0 \text{ or } \sin \theta = 4 \cos \theta$$

$$\Rightarrow \sin \theta = 0 \text{ or } \tan \theta = 4$$

$$\sin \theta = 0 \Rightarrow \theta = 0^\circ, 180^\circ$$

$$\tan \theta = 4 \Rightarrow \theta = \tan^{-1} 4, -180^\circ + \tan^{-1} 4 = 76.0^\circ, -104.0^\circ$$

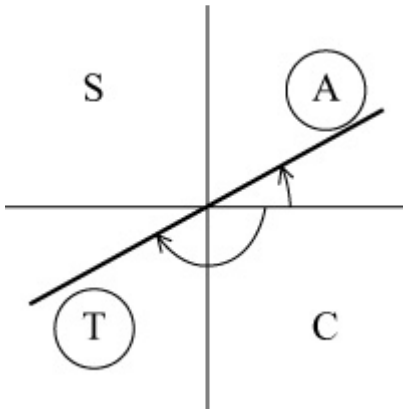

Solution set:  $-104.0^\circ, 0^\circ, 76.0^\circ, 180^\circ$

$$(m) 4 \tan \theta = \tan 2\theta, 0 \leq \theta < 360^\circ$$

$$\Rightarrow 4 \tan \theta = \frac{2 \tan \theta}{1 - \tan^2 \theta}$$

$$\Rightarrow 2 \tan \theta (1 - \tan^2 \theta) = \tan \theta$$

$$\Rightarrow \tan \theta (2 - 2 \tan^2 \theta - 1) = 0$$

$$\Rightarrow \tan \theta (1 - 2 \tan^2 \theta) = 0$$

$$\Rightarrow \tan \theta = 0 \text{ or } \tan \theta = \pm \sqrt{\frac{1}{2}}$$

$$\tan \theta = 0 \Rightarrow \theta = 0^\circ, 180^\circ$$

$$\tan \theta = \pm \sqrt{\frac{1}{2}} \Rightarrow \theta = 35.3^\circ, 144.7^\circ, 215.3^\circ, 324.7^\circ$$

Solution set:  $0^\circ, 35.3^\circ, 144.7^\circ, 180^\circ, 215.3^\circ, 324.7^\circ$

# Solutionbank

## Edexcel AS and A Level Modular Mathematics

Exercise C, Question 4

### Question:

Given that  $p = 2 \cos \theta$  and  $q = \cos 2\theta$ , express  $q$  in terms of  $p$ .

### Solution:

$$p = 2 \cos \theta \quad \Rightarrow \quad \cos \theta = \frac{p}{2}$$

$$\cos 2\theta = q$$

Using  $\cos 2\theta = 2 \cos^2 \theta - 1$

$$q = 2 \left( \frac{p}{2} \right)^2 - 1$$

$$\Rightarrow q = \frac{p^2}{2} - 1$$

© Pearson Education Ltd 2008

# Solutionbank

## Edexcel AS and A Level Modular Mathematics

### Exercise C, Question 5

#### Question:

Eliminate  $\theta$  from the following pairs of equations:

(a)  $x = \cos^2 \theta$ ,  $y = 1 - \cos 2\theta$

(b)  $x = \tan \theta$ ,  $y = \cot 2\theta$

(c)  $x = \sin \theta$ ,  $y = \sin 2\theta$

(d)  $x = 3 \cos 2\theta + 1$ ,  $y = 2 \sin \theta$

#### Solution:

(a)  $\cos^2 \theta = x$ ,  $\cos 2\theta = 1 - y$

Using  $\cos 2\theta = 2 \cos^2 \theta - 1$

$$\Rightarrow 1 - y = 2x - 1$$

$$\Rightarrow y = 2 - 2x = 2(1 - x) \quad (\text{any form})$$

(b)  $y = \cot 2\theta \Rightarrow \tan 2\theta = \frac{1}{y}$

$x = \tan \theta$

Using  $\tan 2\theta = \frac{2 \tan \theta}{1 - \tan^2 \theta}$

$$\Rightarrow \frac{1}{y} = \frac{2x}{1 - x^2}$$

$$\Rightarrow 2xy = 1 - x^2 \quad (\text{any form})$$

(c)  $x = \sin \theta$ ,  $y = 2 \sin \theta \cos \theta$

$$\Rightarrow y = 2x \cos \theta$$

$$\Rightarrow \cos \theta = \frac{y}{2x}$$

Using  $\sin^2 \theta + \cos^2 \theta \equiv 1$

$$\Rightarrow x^2 + \frac{y^2}{4x^2} = 1$$

$$\Rightarrow 4x^4 + y^2 = 4x^2 \text{ or } y^2 = 4x^2(1 - x^2) \quad (\text{any form})$$

$$(d) x = 3 \cos 2\theta + 1 \quad \Rightarrow \quad \cos 2\theta = \frac{x-1}{3}$$

$$y = 2 \sin \theta \quad \Rightarrow \quad \sin \theta = \frac{y}{2}$$

Using  $\cos 2\theta = 1 - 2 \sin^2 \theta$

$$\Rightarrow \quad \frac{x-1}{3} = 1 - \frac{2y^2}{4} = 1 - \frac{y^2}{2}$$

$$\Rightarrow \quad 2(x-1) = 6 - 3y^2 \quad (\times 6)$$

$$\Rightarrow \quad 3y^2 = 6 - 2(x-1) = 8 - 2x$$

$$\Rightarrow \quad y^2 = \frac{2(4-x)}{3} \quad (\text{any form})$$

# Solutionbank

## Edexcel AS and A Level Modular Mathematics

### Exercise C, Question 6

#### Question:

(a) Prove that  $(\cos 2\theta - \sin 2\theta)^2 \equiv 1 - \sin 4\theta$ .

(b) Use the result to solve, for  $0 \leq \theta < \pi$ , the equation  $\cos 2\theta - \sin 2\theta = \frac{1}{\sqrt{2}}$ .

Give your answers in terms of  $\pi$ .

#### Solution:

$$\begin{aligned}
 \text{(a) L.H.S.} &\equiv (\cos 2\theta - \sin 2\theta)^2 \\
 &\equiv \cos^2 2\theta - 2\sin 2\theta \cos 2\theta + \sin^2 2\theta \\
 &\equiv (\cos^2 2\theta + \sin^2 2\theta) - (2\sin 2\theta \cos 2\theta) \\
 &\equiv 1 - \sin 4\theta \quad (\sin^2 A + \cos^2 A \equiv 1, \sin 2A \equiv 2\sin A \cos A) \\
 &\equiv \text{R.H.S.}
 \end{aligned}$$

$$\text{(b) You can use } (\cos 2\theta - \sin 2\theta)^2 = \frac{1}{2}$$

$$\text{but this also solves } \cos 2\theta - \sin 2\theta = -\frac{1}{\sqrt{2}}$$

so you need to check your final answers.

$$\text{As } (\cos 2\theta - \sin 2\theta)^2 \equiv 1 - \sin 4\theta$$

$$\Rightarrow \frac{1}{2} = 1 - \sin 4\theta$$

$$\Rightarrow \sin 4\theta = \frac{1}{2}$$

$$0 \leq \theta < \pi, \text{ so } 0 \leq 4\theta < 4\pi$$

$$\Rightarrow 4\theta = \frac{\pi}{6}, \frac{5\pi}{6}, \frac{13\pi}{6}, \frac{17\pi}{6}$$

$$\Rightarrow \theta = \frac{\pi}{24}, \frac{5\pi}{24}, \frac{13\pi}{24}, \frac{17\pi}{24}$$

$$\text{Checking these values in } \cos 2\theta - \sin 2\theta = \frac{1}{\sqrt{2}}$$

$$\text{eliminates } \frac{5\pi}{24}, \frac{13\pi}{24} \text{ which apply to } \cos 2\theta - \sin 2\theta = -\frac{1}{\sqrt{2}}$$

$$\text{Solutions are } \frac{\pi}{24}, \frac{17\pi}{24}$$

# Solutionbank

## Edexcel AS and A Level Modular Mathematics

Exercise C, Question 7

### Question:

(a) Show that:

$$(i) \sin \theta \equiv \frac{2 \tan \frac{\theta}{2}}{1 + \tan^2 \frac{\theta}{2}}$$

$$(ii) \cos \theta \equiv \frac{1 - \tan^2 \frac{\theta}{2}}{1 + \tan^2 \frac{\theta}{2}}$$

(b) By writing the following equations as quadratics in  $\tan \frac{\theta}{2}$ , solve, in the

interval  $0 \leq \theta \leq 360^\circ$ :

(i)  $\sin \theta + 2 \cos \theta = 1$  (ii)  $3 \cos \theta - 4 \sin \theta = 2$

Give answers to 1 decimal place.

### Solution:

$$(a) (i) \text{ R.H.S.} \equiv \frac{2 \tan \frac{\theta}{2}}{1 + \tan^2 \frac{\theta}{2}}$$

$$\equiv \frac{2 \tan \frac{\theta}{2}}{\sec^2 \frac{\theta}{2}}$$

$$\equiv \frac{2 \sin \frac{\theta}{2}}{\cos \frac{\theta}{2}} \times \cos^2 \frac{\theta}{2}$$

$$\equiv 2 \sin \frac{\theta}{2} \cos \frac{\theta}{2}$$

$$\equiv \sin \theta \quad (\sin 2A = 2 \sin A \cos A)$$

$$\equiv \text{L.H.S.}$$



$$\begin{aligned}
 \text{(ii) R.H.S.} &\equiv \frac{1 - \tan^2 \frac{\theta}{2}}{1 + \tan^2 \frac{\theta}{2}} \\
 &\equiv \frac{1 - \tan^2 \frac{\theta}{2}}{\sec^2 \frac{\theta}{2}} \\
 &\equiv \cos^2 \frac{\theta}{2} \left( 1 - \tan^2 \frac{\theta}{2} \right) \\
 &\equiv \cos^2 \frac{\theta}{2} - \sin^2 \frac{\theta}{2} \quad \left( \tan^2 \frac{\theta}{2} = \frac{\sin^2 \frac{\theta}{2}}{\cos^2 \frac{\theta}{2}} \right) \\
 &\equiv \cos \theta \quad ( \cos 2A = \cos^2 A - \sin^2 A ) \\
 &\equiv \text{L.H.S.}
 \end{aligned}$$

(b) Let  $\tan \frac{\theta}{2} = t$

(i)  $\sin \theta + 2 \cos \theta = 1$

$$\Rightarrow \frac{2t}{1+t^2} + \frac{2(1-t^2)}{1+t^2} = 1$$

$$\Rightarrow 2t + 2 - 2t^2 = 1 + t^2$$

$$\Rightarrow 3t^2 - 2t - 1 = 0$$

$$\Rightarrow (3t + 1)(t - 1) = 0$$

$$\Rightarrow \tan \frac{\theta}{2} = -\frac{1}{3} \text{ or } \tan \frac{\theta}{2} = 1 \quad 0 \leq \frac{\theta}{2} \leq 180^\circ$$

$$\tan \frac{\theta}{2} = 1 \Rightarrow \frac{\theta}{2} = 45^\circ \Rightarrow \theta = 90^\circ$$

$$\tan \frac{\theta}{2} = -\frac{1}{3} \Rightarrow \frac{\theta}{2} = 161.56^\circ \Rightarrow \theta = 323.1^\circ$$

Solution set:  $90^\circ, 323.1^\circ$

(ii)  $3 \cos \theta - 4 \sin \theta = 2$

$$\Rightarrow \frac{3(1-t^2)}{1+t^2} - \frac{4 \times 2t}{1+t^2} = 2$$

$$\Rightarrow 3(1-t^2) - 8t = 2(1+t^2)$$

$$\Rightarrow 5t^2 + 8t - 1 = 0$$

$$\Rightarrow t = \frac{-8 \pm \sqrt{84}}{10}$$

$$\text{For } \tan \frac{\theta}{2} = \frac{-8 + \sqrt{84}}{10} \quad 0 \leq \frac{\theta}{2} \leq 180^\circ$$

$$\frac{\theta}{2} = 6.65^\circ \quad \Rightarrow \quad \theta = 13.3^\circ$$

$$\text{For } \tan \frac{\theta}{2} = \frac{-8 - \sqrt{84}}{10} \quad 0 \leq \frac{\theta}{2} \leq 180^\circ$$

$$\frac{\theta}{2} = 120.2^\circ \quad \Rightarrow \quad \theta = 240.4^\circ$$

Solution set:  $13.3^\circ, 240.4^\circ$

© Pearson Education Ltd 2008

# Solutionbank

## Edexcel AS and A Level Modular Mathematics

### Exercise C, Question 8

#### Question:

(a) Using  $\cos 2A \equiv 2 \cos^2 A - 1 \equiv 1 - 2 \sin^2 A$ , show that:

(i)  $\cos^2 \frac{x}{2} \equiv \frac{1 + \cos x}{2}$

(ii)  $\sin^2 \frac{x}{2} \equiv \frac{1 - \cos x}{2}$

(b) Given that  $\cos \theta = 0.6$ , and that  $\theta$  is acute, write down the values of:

(i)  $\cos \frac{\theta}{2}$

(ii)  $\sin \frac{\theta}{2}$

(iii)  $\tan \frac{\theta}{2}$

(c) Show that  $\cos^4 \frac{A}{2} \equiv \frac{1}{8} (3 + 4 \cos A + \cos 2A)$

#### Solution:

(a) (i) Using  $\cos 2A \equiv 2 \cos^2 A - 1$  with  $A = \frac{x}{2}$

$$\Rightarrow \cos x \equiv 2 \cos^2 \frac{x}{2} - 1$$

$$\Rightarrow 2 \cos^2 \frac{x}{2} \equiv 1 + \cos x$$

$$\Rightarrow \cos^2 \frac{x}{2} \equiv \frac{1 + \cos x}{2}$$

(ii) Using  $\cos 2A \equiv 1 - 2 \sin^2 A$

$$\Rightarrow \cos x \equiv 1 - 2 \sin^2 \frac{x}{2}$$

$$\Rightarrow 2 \sin^2 \frac{x}{2} \equiv 1 - \cos x$$

$$\Rightarrow \sin^2 \frac{x}{2} \equiv \frac{1 - \cos x}{2}$$

(b) Given that  $\cos \theta = 0.6$  and  $\theta$  acute

$$(i) \text{ using (a) (i) } \cos^2 \frac{\theta}{2} = \frac{1.6}{2} = 0.8 = \frac{4}{5}$$

$$\Rightarrow \cos \frac{\theta}{2} = \frac{2}{\sqrt{5}} = \frac{2\sqrt{5}}{5} \quad (\text{as } \frac{\theta}{2} \text{ acute})$$

$$(ii) \text{ using (a) (ii) } \sin^2 \frac{\theta}{2} = \frac{0.4}{2} = 0.2 = \frac{1}{5}$$

$$\Rightarrow \sin \frac{\theta}{2} = \sqrt{\frac{1}{5}} = \frac{\sqrt{5}}{5}$$

$$(iii) \tan \frac{\theta}{2} = \frac{\sin \frac{\theta}{2}}{\cos \frac{\theta}{2}} = \frac{\frac{\sqrt{5}}{5}}{\frac{2\sqrt{5}}{5}} = \frac{\sqrt{5}}{5} \times \frac{5}{2\sqrt{5}} = \frac{1}{2}$$

(c) Using (a) (i) and squaring

$$\cos^4 \frac{A}{2} = \left( \frac{1 + \cos A}{2} \right)^2 = \frac{1 + 2\cos A + \cos^2 A}{4}$$

but using (a) (i) again

$$\cos^2 A = \frac{1}{2} (1 + \cos 2A)$$

$$\text{So } \cos^4 \frac{A}{2} = \frac{1 + 2\cos A + \frac{1}{2} (1 + \cos 2A)}{4} = \frac{2 + 4\cos A + 1 + \cos 2A}{8} =$$

$$\frac{3 + 4\cos A + \cos 2A}{8}$$

# Solutionbank

## Edexcel AS and A Level Modular Mathematics

### Exercise C, Question 9

#### Question:

(a) Show that  $3 \cos^2 x - \sin^2 x \equiv 1 + 2 \cos 2x$ .

(b) Hence sketch, for  $-\pi \leq x \leq \pi$ , the graph of  $y = 3 \cos^2 x - \sin^2 x$ , showing the coordinates of points where the curve meets the axes.

#### Solution:

$$\begin{aligned}
 \text{(a) R.H.S.} &\equiv 1 + 2 \cos 2x \\
 &\equiv 1 + 2 (\cos^2 x - \sin^2 x) \\
 &\equiv 1 + 2 \cos^2 x - 2 \sin^2 x \\
 &\equiv \cos^2 x + \sin^2 x + 2 \cos^2 x - 2 \sin^2 x \quad (\text{using} \\
 &\sin^2 x + \cos^2 x \equiv 1) \\
 &\equiv 3 \cos^2 x - \sin^2 x \\
 &\equiv \text{L.H.S.}
 \end{aligned}$$

$$\begin{aligned}
 \text{(b) } y &= 3 \cos^2 x - \sin^2 x \\
 &\text{is the same as } y = 1 + 2 \cos 2x
 \end{aligned}$$

Using your work on transformations this curve is the result of

- (i) stretching  $y = \cos x$  by scale factor  $\frac{1}{2}$  in the  $x$  direction, then
- (ii) stretching the result by scale factor 2 in the  $y$  direction, then
- (iii) translating by 1 in the +ve  $y$  direction.

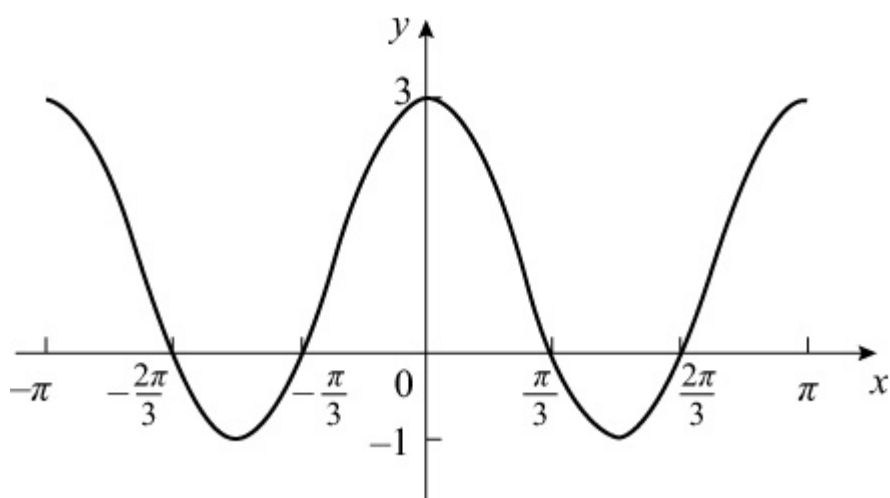

The curve crosses  $y$ -axis at  $(0, 3)$ .

It crosses  $x$ -axis where  $y = 0$

i.e. where  $1 + 2\cos 2x = 0 \quad -\pi \leq x \leq \pi$

$$\Rightarrow \cos 2x = -\frac{1}{2} \quad -2\pi \leq 2x \leq 2\pi$$

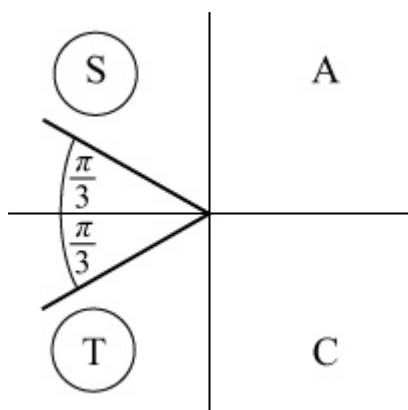

$$\text{So } 2x = -\frac{4\pi}{3}, -\frac{2\pi}{3}, \frac{2\pi}{3}, \frac{4\pi}{3}$$

$$\Rightarrow x = -\frac{2\pi}{3}, -\frac{\pi}{3}, \frac{\pi}{3}, \frac{2\pi}{3}$$

# Solutionbank

## Edexcel AS and A Level Modular Mathematics

### Exercise C, Question 10

#### Question:

(a) Express  $2 \cos^2 \frac{\theta}{2} - 4 \sin^2 \frac{\theta}{2}$  in the form  $a \cos \theta + b$ , where  $a$  and  $b$  are constants.

(b) Hence solve  $2 \cos^2 \frac{\theta}{2} - 4 \sin^2 \frac{\theta}{2} = -3$ , in the interval  $0 \leq \theta < 360^\circ$ , giving answers to 1 decimal place.

#### Solution:

$$(a) \cos^2 \frac{\theta}{2} = \frac{1 + \cos \theta}{2}, \quad \sin^2 \frac{\theta}{2} = \frac{1 - \cos \theta}{2}$$

$$\text{So } 2 \cos^2 \frac{\theta}{2} - 4 \sin^2 \frac{\theta}{2} = (1 + \cos \theta) - 2(1 - \cos \theta) = 3 \cos \theta - 1$$

(b) Hence solve  $3 \cos \theta - 1 = -3$ ,  $0 \leq \theta < 360^\circ$

$$\Rightarrow 3 \cos \theta = -2$$

$$\Rightarrow \cos \theta = -\frac{2}{3}$$

As  $\cos \theta$  is  $-ve$ ,  $\theta$  is in 2nd and 3rd quadrants.

Calculator value is  $\cos^{-1} \left( -\frac{2}{3} \right) = 131.8^\circ$

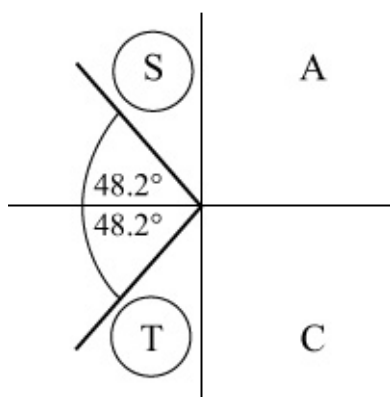

Solutions are  $131.8^\circ$ ,  $360^\circ - 131.8^\circ = 228.2^\circ$

# Solutionbank

## Edexcel AS and A Level Modular Mathematics

### Exercise C, Question 11

#### Question:

(a) Use the identity  $\sin^2 A + \cos^2 A \equiv 1$  to show that  $\sin^4 A + \cos^4 A \equiv \frac{1}{2} (2 - \sin^2 2A)$ .

(b) Deduce that  $\sin^4 A + \cos^4 A \equiv \frac{1}{4} (3 + \cos 4A)$ .

(c) Hence solve  $8 \sin^4 \theta + 8 \cos^4 \theta = 7$ , for  $0 < \theta < \pi$ .

#### Solution:

(a) As  $\sin^2 A + \cos^2 A \equiv 1$

so  $(\sin^2 A + \cos^2 A)^2 \equiv 1$

$$\Rightarrow \sin^4 A + \cos^4 A + 2 \sin^2 A \cos^2 A \equiv 1$$

$$\Rightarrow \sin^4 A + \cos^4 A \equiv 1 - 2 \sin^2 A \cos^2 A$$

$$\equiv 1 - \frac{1}{2} (4 \sin^2 A \cos^2 A)$$

$$\equiv 1 - \frac{1}{2} \left[ (2 \sin A \cos A)^2 \right]$$

$$\equiv 1 - \frac{1}{2} \sin^2 2A$$

$$\equiv \frac{1}{2} (2 - \sin^2 2A)$$

(b) As  $\cos 2A \equiv 1 - 2 \sin^2 A$

so  $\cos 4A \equiv 1 - 2 \sin^2 2A$

so  $\sin^2 2A \equiv \frac{1 - \cos 4A}{2}$

$$\Rightarrow \text{from (a) } \sin^4 A + \cos^4 A \equiv \frac{1}{2} \left( 2 - \frac{1 - \cos 4A}{2} \right) \equiv \frac{1}{2} \left( \frac{4 - 1 + \cos 4A}{2} \right)$$

$$\equiv \frac{1}{4} (3 + \cos 4A)$$



(c) Using part (b)

$$8 \sin^4 \theta + 8 \cos^4 \theta = 7$$

$$\Rightarrow 8 \times \frac{1}{4} (3 + \cos 4\theta) = 7$$

$$\Rightarrow 3 + \cos 4\theta = \frac{7}{2}$$

$$\Rightarrow \cos 4\theta = \frac{1}{2}$$

Solve  $\cos 4\theta = \frac{1}{2}$  in  $0 < 4\theta < 4\pi$

$$\Rightarrow 4\theta = \frac{\pi}{3}, \frac{5\pi}{3}, \frac{7\pi}{3}, \frac{11\pi}{3}$$

$$\Rightarrow \theta = \frac{\pi}{12}, \frac{5\pi}{12}, \frac{7\pi}{12}, \frac{11\pi}{12}$$

# Solutionbank

## Edexcel AS and A Level Modular Mathematics

Exercise C, Question 12

### Question:

- (a) By expanding  $\cos(2A + A)$  show that  $\cos 3A \equiv 4\cos^3 A - 3\cos A$ .
- (b) Hence solve  $8\cos^3 \theta - 6\cos \theta - 1 = 0$ , for  $\{0 \leq \theta \leq 360^\circ\}$ .

### Solution:

$$\begin{aligned}
 \text{(a) } \cos(2A + A) &\equiv \cos 2A \cos A - \sin 2A \sin A \\
 &\equiv (2\cos^2 A - 1) \cos A - (2\sin A \cos A) \sin A \\
 &\equiv 2\cos^3 A - \cos A - 2\sin^2 A \cos A \\
 &\equiv 2\cos^3 A - \cos A - 2(1 - \cos^2 A) \cos A \\
 &\equiv 2\cos^3 A - \cos A - 2\cos A + 2\cos^3 A \\
 &\equiv 4\cos^3 A - 3\cos A
 \end{aligned}$$

$$\begin{aligned}
 \text{(b) } 8\cos^3 \theta - 6\cos \theta - 1 &= 0 \quad 0 \leq \theta \leq 360^\circ \\
 \Rightarrow 2(4\cos^3 \theta - 3\cos \theta) - 1 &= 0 \\
 \Rightarrow 2\cos 3\theta - 1 &= 0 \quad [\text{using part (a)}] \\
 \Rightarrow \cos 3\theta &= \frac{1}{2}
 \end{aligned}$$

$$\text{Solve } \cos 3\theta = \frac{1}{2} \text{ in } 0 \leq 3\theta \leq 1080^\circ$$

$$\Rightarrow 3\theta = 60^\circ, 300^\circ, 420^\circ, 660^\circ, 780^\circ, 1020^\circ$$

$$\Rightarrow \theta = 20^\circ, 100^\circ, 140^\circ, 220^\circ, 260^\circ, 340^\circ$$

# Solutionbank

## Edexcel AS and A Level Modular Mathematics

### Exercise C, Question 13

#### Question:

(a) Show that  $\tan 3\theta \equiv \frac{3 \tan \theta - \tan^3 \theta}{1 - 3 \tan^2 \theta}$ .

(b) Given that  $\theta$  is acute such that  $\cos \theta = \frac{1}{3}$ , show that  $\tan 3\theta = \frac{10\sqrt{2}}{23}$ .

#### Solution:

$$(a) \tan 3\theta \equiv \tan (2\theta + \theta) \equiv \frac{\tan 2\theta + \tan \theta}{1 - \tan 2\theta \tan \theta}$$

$$\text{Numerator} = \frac{2 \tan \theta}{1 - \tan^2 \theta} + \tan \theta \equiv \frac{2 \tan \theta + \tan \theta - \tan^3 \theta}{1 - \tan^2 \theta} \equiv \frac{3 \tan \theta - \tan^3 \theta}{1 - \tan^2 \theta}$$

$$\text{Denominator} = 1 - \frac{2 \tan \theta}{1 - \tan^2 \theta} \tan \theta \equiv \frac{1 - \tan^2 \theta - 2 \tan^2 \theta}{1 - \tan^2 \theta} \equiv \frac{1 - 3 \tan^2 \theta}{1 - \tan^2 \theta}$$

$$\text{So } \tan 3\theta \equiv \frac{3 \tan \theta - \tan^3 \theta}{1 - \tan^2 \theta} \times \frac{1 - \tan^2 \theta}{1 - 3 \tan^2 \theta} \equiv \frac{3 \tan \theta - \tan^3 \theta}{1 - 3 \tan^2 \theta}$$

(b) Draw a right-angled triangle.

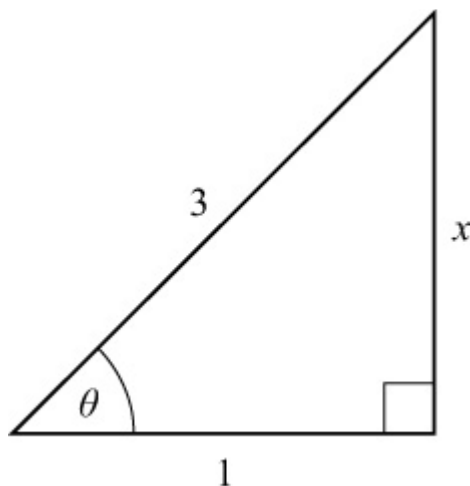

Using Pythagoras' theorem

$$x^2 = 9 - 1 = 8$$

$$\text{So } x = 2\sqrt{2}$$

$$\text{So } \tan \theta = 2\sqrt{2}$$

Using part (a)

$$\tan 3\theta = \frac{3(2\sqrt{2}) - (2\sqrt{2})^3}{1 - 3(2\sqrt{2})^2} = \frac{6\sqrt{2} - 16\sqrt{2}}{1 - 24} = \frac{-10\sqrt{2}}{-23} = \frac{10\sqrt{2}}{23}$$

© Pearson Education Ltd 2008

# Solutionbank

## Edexcel AS and A Level Modular Mathematics

### Exercise D, Question 1

#### Question:

Given that  $5 \sin \theta + 12 \cos \theta \equiv R \sin (\theta + \alpha)$ , find the value of  $R$ ,  $R > 0$ , and the value of  $\tan \alpha$ .

#### Solution:

$$5 \sin \theta + 12 \cos \theta \equiv R \sin \theta \cos \alpha + R \cos \theta \sin \alpha$$

$$\text{Comparing } \sin \theta : \quad R \cos \alpha = 5$$

$$\text{Comparing } \cos \theta \quad R \sin \alpha = 12$$

Divide the equations:

$$\frac{\sin \alpha}{\cos \alpha} = \frac{12}{5} \quad \Rightarrow \quad \tan \alpha = 2 \frac{2}{5}$$

Square and add the equations:

$$R^2 \cos^2 \alpha + R^2 \sin^2 \alpha = 5^2 + 12^2$$

$$R^2 (\cos^2 \alpha + \sin^2 \alpha) = 13^2$$

$$R = 13$$

$$\text{since } \cos^2 \alpha + \sin^2 \alpha \equiv 1$$

# Solutionbank

## Edexcel AS and A Level Modular Mathematics

### Exercise D, Question 2

#### Question:

Given that  $\sqrt{3} \sin \theta + \sqrt{6} \cos \theta \equiv 3 \cos (\theta - \alpha)$ , where  $0 < \alpha < 90^\circ$ , find the value of  $\alpha$  to the nearest  $0.1^\circ$ .

#### Solution:

$$\sqrt{3} \sin \theta + \sqrt{6} \cos \theta \equiv 3 \cos \theta \cos \alpha + 3 \sin \theta \sin \alpha$$

Comparing  $\sin \theta$ :  $\sqrt{3} = 3 \sin \alpha$  ①

Comparing  $\cos \theta$ :  $\sqrt{6} = 3 \cos \alpha$  ②

Divide ① by ②:

$$\tan \alpha = \frac{\sqrt{3}}{\sqrt{6}} = \frac{1}{\sqrt{2}}$$

So  $\alpha = 35.3^\circ$

# Solutionbank

## Edexcel AS and A Level Modular Mathematics

### Exercise D, Question 3

#### Question:

Given that  $2 \sin \theta - \sqrt{5} \cos \theta \equiv -3 \cos (\theta + \alpha)$ , where  $0 < \alpha < 90^\circ$ , find the value of  $\alpha$  to the nearest  $0.1^\circ$ .

#### Solution:

$$2 \sin \theta - \sqrt{5} \cos \theta \equiv -3 \cos \theta \cos \alpha + 3 \sin \theta \sin \alpha$$

$$\text{Comparing } \sin \theta : \quad 2 = 3 \sin \alpha \quad \textcircled{1}$$

$$\text{Comparing } \cos \theta : \quad + \sqrt{5} = + 3 \cos \alpha \quad \textcircled{2}$$

Divide  $\textcircled{1}$  by  $\textcircled{2}$ :

$$\tan \alpha = \frac{2}{\sqrt{5}}$$

$$\text{So } \alpha = 41.8^\circ$$

# Solutionbank

## Edexcel AS and A Level Modular Mathematics

### Exercise D, Question 4

#### Question:

Show that:

$$(a) \cos \theta + \sin \theta \equiv \sqrt{2} \sin \left( \theta + \frac{\pi}{4} \right)$$

$$(b) \sqrt{3} \sin 2\theta - \cos 2\theta \equiv 2 \sin \left( 2\theta - \frac{\pi}{6} \right)$$

#### Solution:

$$\begin{aligned} (a) \text{ R.H.S.} &\equiv \sqrt{2} \sin \left( \theta + \frac{\pi}{4} \right) \\ &\equiv \sqrt{2} \left( \sin \theta \cos \frac{\pi}{4} + \cos \theta \sin \frac{\pi}{4} \right) \\ &\equiv \sqrt{2} \left( \sin \theta \times \frac{1}{\sqrt{2}} + \cos \theta \times \frac{1}{\sqrt{2}} \right) \\ &\equiv \sin \theta + \cos \theta \\ &\equiv \text{L.H.S.} \end{aligned}$$

$$\begin{aligned} (b) \text{ R.H.S.} &\equiv 2 \sin \left( 2\theta - \frac{\pi}{6} \right) \\ &\equiv 2 \left( \sin 2\theta \cos \frac{\pi}{6} - \cos 2\theta \sin \frac{\pi}{6} \right) \\ &\equiv 2 \left( \sin 2\theta \times \frac{\sqrt{3}}{2} - \cos 2\theta \times \frac{1}{2} \right) \\ &\equiv \sqrt{3} \sin 2\theta - \cos 2\theta \\ &\equiv \text{L.H.S.} \end{aligned}$$



# Solutionbank

## Edexcel AS and A Level Modular Mathematics

### Exercise D, Question 5

#### Question:

Prove that  $\cos 2\theta - \sqrt{3} \sin 2\theta \equiv 2 \cos \left( 2\theta + \frac{\pi}{3} \right) \equiv -2 \sin \left( 2\theta - \frac{\pi}{6} \right)$ .

#### Solution:

Let  $\cos 2\theta - \sqrt{3} \sin 2\theta \equiv R \cos (2\theta + \alpha) \equiv R \cos 2\theta \cos \alpha - R \sin 2\theta \sin \alpha$

Compare  $\cos 2\theta$ :  $R \cos \alpha = 1$  ①

Compare  $\sin 2\theta$ :  $R \sin \alpha = \sqrt{3}$  ②

Divide ② by ①:

$$\tan \alpha = \sqrt{3} \Rightarrow \alpha = \frac{\pi}{3}$$

Square and add equations:

$$R^2 = 1 + 3 = 4$$

$$\Rightarrow R = 2$$

So  $\cos 2\theta - \sqrt{3} \sin 2\theta \equiv 2 \cos \left( 2\theta + \frac{\pi}{3} \right)$

$$\begin{aligned} \cos \left( 2\theta + \frac{\pi}{3} \right) &\equiv \cos 2\theta \cos \frac{\pi}{3} - \sin 2\theta \sin \frac{\pi}{3} \\ &\equiv \cos 2\theta \times \frac{1}{2} - \sin 2\theta \times \frac{\sqrt{3}}{2} \\ &\equiv \cos 2\theta \sin \frac{\pi}{6} - \sin 2\theta \cos \frac{\pi}{6} \\ &\equiv - \left( \sin 2\theta \cos \frac{\pi}{6} - \cos 2\theta \sin \frac{\pi}{6} \right) \\ &\equiv - \sin \left( 2\theta - \frac{\pi}{6} \right) \end{aligned}$$

So  $\cos 2\theta - \sqrt{3} \sin 2\theta \equiv 2 \cos \left( 2\theta + \frac{\pi}{3} \right) \equiv -2 \sin \left( 2\theta - \frac{\pi}{6} \right)$

# Solutionbank

## Edexcel AS and A Level Modular Mathematics

### Exercise D, Question 6

#### Question:

Give all angles to the nearest  $0.1^\circ$  and non-exact values of  $R$  in surd form.  
Find the value of  $R$ , where  $R > 0$ , and the value of  $\alpha$ , where  $0 < \alpha < 90^\circ$ , in each of the following cases:

(a)  $\sin \theta + 3 \cos \theta \equiv R \sin (\theta + \alpha)$

(b)  $3 \sin \theta - 4 \cos \theta \equiv R \sin (\theta - \alpha)$

(c)  $2 \cos \theta + 7 \sin \theta \equiv R \cos (\theta - \alpha)$

(d)  $\cos 2\theta - 2 \sin 2\theta \equiv R \cos (2\theta + \alpha)$

#### Solution:

(a)  $\sin \theta + 3 \cos \theta \equiv R \sin \theta \cos \alpha + R \cos \theta \sin \alpha$

Compare  $\sin \theta$ :  $R \cos \alpha = 1$  ①

Compare  $\cos \theta$ :  $R \sin \alpha = 3$  ②

Dividing ② by ①:

$$\tan \alpha = 3 \Rightarrow \alpha = 71.6^\circ$$

Square and add equations:

$$R^2 = 3^2 + 1^2 \Rightarrow R = \sqrt{10}$$

(b)  $3 \sin \theta - 4 \cos \theta \equiv R \sin \theta \cos \alpha - R \cos \theta \sin \alpha$

Compare  $\sin \theta$ :  $R \cos \alpha = 3$  ①

Compare  $\cos \theta$ :  $R \sin \alpha = 4$  ②

Divide ② by ①:

$$\tan \alpha = \frac{4}{3} \Rightarrow \alpha = 53.1^\circ$$

Square and add equations:

$$R^2 = 3^2 + 4^2 \Rightarrow R = 5$$

(c)  $2 \cos \theta + 7 \sin \theta \equiv R \cos \theta \cos \alpha + R \sin \theta \sin \alpha$

Compare  $\cos \theta$ :  $R \cos \alpha = 2$  ①

Compare  $\sin \theta$ :  $R \sin \alpha = 7$  ②

Divide ② by ①:

$$\tan \alpha = \frac{7}{2} \Rightarrow \alpha = 74.1^\circ$$

Square and add equations:

$$R^2 = 2^2 + 7^2 = 53 \Rightarrow R = \sqrt{53}$$

$$(d) \cos 2\theta - 2 \sin 2\theta \equiv R \cos 2\theta \cos \alpha - R \sin 2\theta \sin \alpha$$

$$\text{Compare } \cos 2\theta : \quad R \cos \alpha = 1 \quad \textcircled{1}$$

$$\text{Compare } \sin 2\theta : \quad R \sin \alpha = 2 \quad \textcircled{2}$$

Divide  $\textcircled{2}$  by  $\textcircled{1}$ :

$$\tan \alpha = 2 \Rightarrow \alpha = 63.4^\circ$$

Square and add equations:

$$R^2 = 1^2 + 2^2 = 5 \Rightarrow R = \sqrt{5}$$

# Solutionbank

## Edexcel AS and A Level Modular Mathematics

### Exercise D, Question 7

#### Question:

(a) Show that  $\cos \theta - \sqrt{3} \sin \theta$  can be written in the form  $R \cos (\theta + \alpha)$ , with  $R > 0$  and  $0 < \alpha < \frac{\pi}{2}$ .

(b) Hence sketch the graph of  $y = \cos \theta - \sqrt{3} \sin \theta$ ,  $0 < \theta < 2\pi$ , giving the coordinates of points of intersection with the axes.

#### Solution:

(a) Let  $\cos \theta - \sqrt{3} \sin \theta \equiv R \cos (\theta + \alpha) \equiv R \cos \theta \cos \alpha - R \sin \theta \sin \alpha$

Compare  $\cos \theta$ :  $R \cos \alpha = 1$  ①

Compare  $\sin \theta$ :  $R \sin \alpha = \sqrt{3}$  ②

Divide ② by ①:  $\tan \alpha = \sqrt{3} \Rightarrow \alpha = \frac{\pi}{3}$

Square and add:  $R^2 = 1 + 3 = 4 \Rightarrow R = 2$

So  $\cos \theta - \sqrt{3} \sin \theta \equiv 2 \cos \left( \theta + \frac{\pi}{3} \right)$

(b) This is the graph of  $y = \cos \theta$ , translated by  $\frac{\pi}{3}$  to the left and then stretched in the  $y$  direction by scale factor 2.

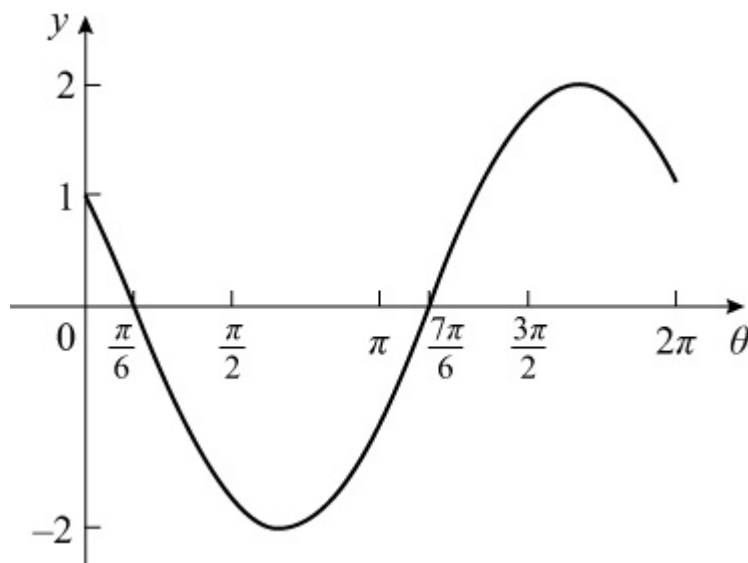

Meets  $y$ -axis at  $(0, 1)$

Meets  $x$ -axis at  $\left(\frac{\pi}{6}, 0\right), \left(\frac{7\pi}{6}, 0\right)$

© Pearson Education Ltd 2008

# Solutionbank

## Edexcel AS and A Level Modular Mathematics

### Exercise D, Question 8

#### Question:

(a) Show that  $3 \sin 3\theta - 4 \cos 3\theta$  can be written in the form  $R \sin (3\theta - \alpha)$ , with  $R > 0$  and  $0 < \alpha < 90^\circ$ .

(b) Deduce the minimum value of  $3 \sin 3\theta - 4 \cos 3\theta$  and work out the smallest positive value of  $\theta$  (to the nearest  $0.1^\circ$ ) at which it occurs.

#### Solution:

(a) Let  $3 \sin 3\theta - 4 \cos 3\theta \equiv R \sin (3\theta - \alpha) \equiv R \sin 3\theta \cos \alpha - R \cos 3\theta \sin \alpha$

Compare  $\sin 3\theta$ :  $R \cos \alpha = 3$  ①

Compare  $\cos 3\theta$ :  $R \sin \alpha = 4$  ②

Divide ② by ①:  $\tan \alpha = \frac{4}{3} \Rightarrow \alpha = 53.1^\circ$

Square and add:  $R^2 = 3^2 + 4^2 \Rightarrow R = 5$

So  $3 \sin 3\theta - 4 \cos 3\theta \equiv 5 \sin (3\theta - 53.1^\circ)$

(b) Minimum value occurs when  $\sin (3\theta - 53.1^\circ) = -1$

So minimum value is  $-5$

To find smallest +ve value of  $\theta$  solve  $\sin (3\theta - 53.1^\circ) = -1$

So  $3\theta - 53.1^\circ = 270^\circ$

$\Rightarrow 3\theta = 323.1^\circ$

$\Rightarrow \theta = 107.7^\circ$

# Solutionbank

## Edexcel AS and A Level Modular Mathematics

### Exercise D, Question 9

#### Question:

(a) Show that  $\cos 2\theta + \sin 2\theta$  can be written in the form  $R \sin (2\theta + \alpha)$ , with  $R > 0$  and  $0 < \alpha < \frac{\pi}{2}$ .

(b) Hence solve, in the interval  $0 \leq \theta < 2\pi$ , the equation  $\cos 2\theta + \sin 2\theta = 1$ , giving your answers as rational multiples of  $\pi$ .

#### Solution:

(a) Let  $\cos 2\theta + \sin 2\theta \equiv R \sin (2\theta + \alpha) \equiv R \sin 2\theta \cos \alpha + R \cos 2\theta \sin \alpha$

Compare  $\cos 2\theta$ :  $R \sin \alpha = 1$  ①

Compare  $\sin 2\theta$ :  $R \cos \alpha = 1$  ②

Divide ① by ②:  $\tan \alpha = 1 \Rightarrow \alpha = \frac{\pi}{4}$

Square and add:  $R^2 = 1^2 + 1^2 = 2 \Rightarrow R = \sqrt{2}$

So  $\cos 2\theta + \sin 2\theta \equiv \sqrt{2} \sin \left( 2\theta + \frac{\pi}{4} \right)$

(b) Solve  $\sqrt{2} \sin \left( 2\theta + \frac{\pi}{4} \right) = 1, 0 \leq \theta < 2\pi$

so  $\sin \left( 2\theta + \frac{\pi}{4} \right) = \frac{1}{\sqrt{2}}, \frac{\pi}{4} \leq 2\theta + \frac{\pi}{4} < \frac{17\pi}{4}$

As  $\sin \left( 2\theta + \frac{\pi}{4} \right)$  is +ve,  $\left( 2\theta + \frac{\pi}{4} \right)$  is in 1st and 2nd quadrants.

Calculator value is  $\sin^{-1} \frac{1}{\sqrt{2}} = \frac{\pi}{4}$

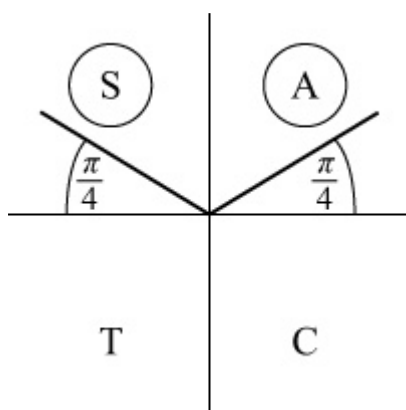

$$\text{So } 2\theta + \frac{\pi}{4} = \frac{\pi}{4}, \frac{3\pi}{4}, \frac{9\pi}{4}, \frac{11\pi}{4}$$

$$\Rightarrow 2\theta = 0, \frac{\pi}{2}, 2\pi, \frac{5\pi}{2}$$

$$\Rightarrow \theta = 0, \frac{\pi}{4}, \pi, \frac{5\pi}{4}$$

© Pearson Education Ltd 2008



# Solutionbank

## Edexcel AS and A Level Modular Mathematics

### Exercise D, Question 10

#### Question:

- (a) Express  $7 \cos \theta - 24 \sin \theta$  in the form  $R \cos (\theta + \alpha)$ , with  $R > 0$  and  $0 < \alpha < 90^\circ$ . Give  $\alpha$  to the nearest  $0.1^\circ$ .
- (b) The graph of  $y = 7 \cos \theta - 24 \sin \theta$  meets the y-axis at P. State the coordinates of P.
- (c) Write down the maximum and minimum values of  $7 \cos \theta - 24 \sin \theta$ .
- (d) Deduce the number of solutions, in the interval  $0 < \theta < 360^\circ$ , of the following equations:
- (i)  $7 \cos \theta - 24 \sin \theta = 15$   
(ii)  $7 \cos \theta - 24 \sin \theta = 26$   
(iii)  $7 \cos \theta - 24 \sin \theta = -25$

#### Solution:

(a) Let  $7 \cos \theta - 24 \sin \theta \equiv R \cos (\theta + \alpha) \equiv R \cos \theta \cos \alpha - R \sin \theta \sin \alpha$

Compare  $\cos \theta$ :  $R \cos \alpha = 7$  ①

Compare  $\sin \theta$ :  $R \sin \alpha = 24$  ②

Divide ② by ①:  $\tan \alpha = \frac{24}{7} \Rightarrow \alpha = 73.7^\circ$

Square and add:  $R^2 = 24^2 + 7^2 \Rightarrow R = 25$

So  $7 \cos \theta - 24 \sin \theta \equiv 25 \cos (\theta + 73.7^\circ)$

(b) Graph meets y-axis where  $\theta = 0$ ,

i.e.  $y = 7 \cos 0^\circ - 24 \sin 0^\circ = 7$

so coordinates are  $(0, 7)$

(c) Maximum value of  $25 \cos (\theta + 73.7^\circ)$  is when  $\cos (\theta + 73.7^\circ) = 1$

So maximum is 25

Minimum value is  $25 (-1) = -25$

(d) (i) The line  $y = 15$  will meet the graph twice in  $0 < \theta < 360^\circ$ , so there are 2 solutions.

(ii) As the maximum value is 25 it can never be 26, so there are 0 solutions.

(iii) As  $-25$  is a minimum, line  $y = -25$  only meets curve once, so only 1 solution.



# Solutionbank

## Edexcel AS and A Level Modular Mathematics

### Exercise D, Question 11

#### Question:

(a) Express  $5 \sin^2 \theta - 3 \cos^2 \theta + 6 \sin \theta \cos \theta$  in the form  $a \sin 2\theta + b \cos 2\theta + c$ , where  $a$ ,  $b$  and  $c$  are constants.

(b) Hence find the maximum and minimum values of  $5 \sin^2 \theta - 3 \cos^2 \theta + 6 \sin \theta \cos \theta$ .

#### Solution:

(a) As  $\sin^2 \theta = \frac{1 - \cos 2\theta}{2}$  and  $\cos^2 \theta = \frac{1 + \cos 2\theta}{2}$

so  $5 \sin^2 \theta - 3 \cos^2 \theta + 6 \sin \theta \cos \theta$

$$\equiv 5 \frac{1 - \cos 2\theta}{2} - 3 \frac{1 + \cos 2\theta}{2} + 3 (2 \sin \theta \cos \theta)$$

$$\equiv \frac{5}{2} - \frac{5}{2} \cos 2\theta - \frac{3}{2} - \frac{3}{2} \cos 2\theta + 3 \sin 2\theta$$

$$\equiv 1 - 4 \cos 2\theta + 3 \sin 2\theta$$

(b) Write  $3 \sin 2\theta - 4 \cos 2\theta$  in the form  $R \sin (2\theta - \alpha)$

The maximum value of  $R \sin (2\theta - \alpha)$  is  $R$

The minimum value of  $R \sin (2\theta - \alpha)$  is  $-R$

You know that  $R^2 = 3^2 + 4^2$  so  $R = 5$

So maximum value of  $1 - 4 \cos 2\theta + 3 \sin 2\theta$  is  $1 + 5 = 6$

and minimum value of  $1 - 4 \cos 2\theta + 3 \sin 2\theta$  is  $1 - 5 = -4$

# Solutionbank

## Edexcel AS and A Level Modular Mathematics

### Exercise D, Question 12

#### Question:

Solve the following equations, in the interval given in brackets. Give all angles to the nearest  $0.1^\circ$ .

(a)  $6 \sin x + 8 \cos x = 5 \sqrt{3}$   $[0, 360^\circ]$

(b)  $2 \cos 3\theta - 3 \sin 3\theta = -1$   $[0, 90^\circ]$

(c)  $8 \cos \theta + 15 \sin \theta = 10$   $[0, 360^\circ]$

(d)  $5 \sin \frac{x}{2} - 12 \cos \frac{x}{2} = -6.5$   $[-360^\circ, 360^\circ]$

#### Solution:

(a) Write  $6 \sin x + 8 \cos x$  in the form  $R \sin(x + \alpha)$ , where  $R > 0$ ,  $0 < \alpha < 90^\circ$   
so  $6 \sin x + 8 \cos x \equiv R \sin x \cos \alpha + R \cos x \sin \alpha$

Compare  $\sin x$ :  $R \cos \alpha = 6$  ①

Compare  $\cos x$ :  $R \sin \alpha = 8$  ②

Divide ② by ①:  $\tan \alpha = \frac{4}{3} \Rightarrow \alpha = 53.13^\circ$

$$R^2 = 6^2 + 8^2 \Rightarrow R = 10$$

So  $6 \sin x + 8 \cos x \equiv 10 \sin(x + 53.13^\circ)$

Solve  $10 \sin(x + 53.13^\circ) = 5 \sqrt{3}$ ,  $0 \leq x \leq 360^\circ$

so  $\sin(x + 53.13^\circ) = \frac{\sqrt{3}}{2}$

$$\Rightarrow x + 53.13^\circ = 60^\circ, 120^\circ$$

$$\Rightarrow x = 6.9^\circ, 66.9^\circ$$

(b) Let  $2 \cos 3\theta - 3 \sin 3\theta \equiv R \cos(3\theta + \alpha) \equiv R \cos 3\theta \cos \alpha - R \sin 3\theta \sin \alpha$

Compare  $\cos 3\theta$ :  $R \cos \alpha = 2$  ①

Compare  $\sin 3\theta$ :  $R \sin \alpha = 3$  ②

Divide ② by ①:  $\tan \alpha = \frac{3}{2} \Rightarrow \alpha = 56.31^\circ$

$$R^2 = 2^2 + 3^2 \Rightarrow R = \sqrt{13}$$

Solve  $\sqrt{13} \cos(3\theta + 56.31^\circ) = -1$ ,  $0 \leq \theta \leq 90^\circ$

so  $\cos ( 3\theta + 56.31^\circ ) = -\frac{1}{\sqrt{13}}$  for

$$56.31^\circ \leq 3\theta + 56.31^\circ \leq 326.31^\circ$$

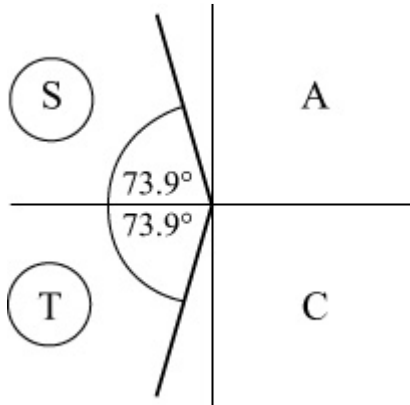

$$\Rightarrow 3\theta + 56.31^\circ = 106.1^\circ, 253.9^\circ$$

$$\Rightarrow 3\theta = 49.8^\circ, 197.6^\circ$$

$$\Rightarrow \theta = 16.6^\circ, 65.9^\circ$$

(c) Let  $8 \cos \theta + 15 \sin \theta \equiv R \cos (\theta - \alpha) \equiv R \cos \theta \cos \alpha + R \sin \theta \sin \alpha$

Compare  $\cos \theta$ :  $R \cos \alpha = 8$  ①

Compare  $\sin \theta$ :  $R \sin \alpha = 15$  ②

Divide ② by ①:  $\tan \alpha = \frac{15}{8} \Rightarrow \alpha = 61.93^\circ$

$$R^2 = 8^2 + 15^2 \Rightarrow R = 17$$

Solve  $17 \cos (\theta - 61.93^\circ) = 10, 0 \leq \theta \leq 360^\circ$

so  $\cos \left( \theta - 61.93^\circ \right) = \frac{10}{17}, -61.93^\circ \leq \theta - 61.93^\circ \leq 298.1^\circ$

$$\cos^{-1} \left( \frac{10}{17} \right) = 53.97^\circ$$

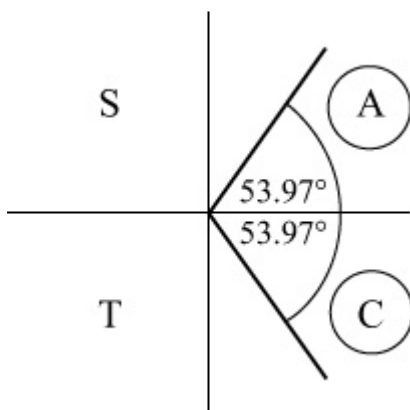

So  $\theta - 61.93^\circ = -53.97^\circ, +53.97^\circ$

$$\Rightarrow \theta = 8.0^\circ, 115.9^\circ$$

$$(d) \text{ Let } 5 \sin \frac{x}{2} - 12 \cos \frac{x}{2} \equiv R \sin \left( \frac{x}{2} - \alpha \right) \equiv R \sin \frac{x}{2} \cos \alpha - R \cos \frac{x}{2} \sin \alpha$$

$$\text{Compare } \sin \frac{x}{2} : \quad R \cos \alpha = 5 \quad \textcircled{1}$$

$$\text{Compare } \cos \frac{x}{2} : \quad R \sin \alpha = 12 \quad \textcircled{2}$$

$$\text{Divide } \textcircled{2} \text{ by } \textcircled{1}: \quad \tan \alpha = \frac{12}{5} \Rightarrow \alpha = 67.38^\circ$$

$$R = 13$$

$$\text{Solve } 13 \sin \left( \frac{x}{2} - 67.38^\circ \right) = -6.5, \quad -360^\circ \leq x \leq 360^\circ$$

$$\text{so } \sin \left( \frac{x}{2} - 67.38^\circ \right) = -\frac{1}{2}, \quad -247.4^\circ \leq$$

$$\frac{x}{2} - 67.4^\circ \leq 112.6^\circ$$

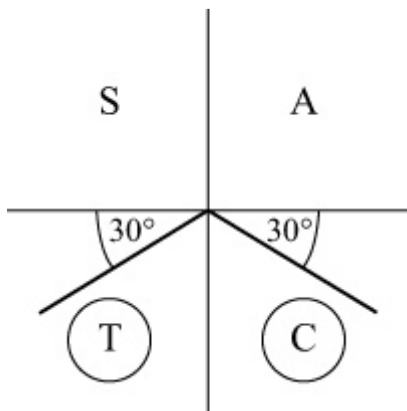

From quadrant diagram:

$$\frac{x}{2} - 67.4^\circ = -150^\circ, -30^\circ$$

$$\Rightarrow \frac{x}{2} = -82.6^\circ, 37.4^\circ$$

$$\Rightarrow x = -165.2^\circ, 74.8^\circ$$

# Solutionbank

## Edexcel AS and A Level Modular Mathematics

### Exercise D, Question 13

#### Question:

Solve the following equations, in the interval given in brackets. Give all angles to the nearest  $0.1^\circ$ .

(a)  $\sin x \cos x = 1 - 2.5 \cos 2x$      $[ 0 , 360^\circ ]$

(b)  $\cot \theta + 2 = \operatorname{cosec} \theta$      $[ 0 < \theta < 360, \theta \neq 180 ]$

(c)  $\sin \theta = 2 \cos \theta - \sec \theta$      $[ 0 , 180^\circ ]$

(d)  $\sqrt{2} \cos \left( \theta - \frac{\pi}{4} \right) + \left( \sqrt{3} - 1 \right) \sin \theta = 2$      $[ 0 , 2\pi ]$

#### Solution:

(a)  $\sin x \cos x = 1 - 2.5 \cos 2x, 0 \leq x \leq 360^\circ$

$$\Rightarrow \frac{1}{2} \sin 2x = 1 - 2.5 \cos 2x$$

$$\Rightarrow \sin 2x + 5 \cos 2x = 2$$

Let  $\sin 2x + 5 \cos 2x \equiv R \sin ( 2x + \alpha ) \equiv R \sin 2x \cos \alpha + R \cos 2x \sin \alpha$

Compare  $\sin 2x$  :     $R \cos \alpha = 1$     ①

Compare  $\cos 2x$  :     $R \sin \alpha = 5$     ②

Divide ② by ①:     $\tan \alpha = 5 \Rightarrow \alpha = \tan^{-1} 5 = 78.7^\circ$

$$R^2 = 5^2 + 1^2 \Rightarrow R = \sqrt{26}$$

Solve  $\sqrt{26} \sin ( 2x + 78.7^\circ ) = 2, 0 \leq x \leq 360^\circ$

$$\Rightarrow \sin \left( 2x + 78.7^\circ \right) = \frac{2}{\sqrt{26}}, 78.7^\circ \leq 2x + 78.7^\circ \leq 798.7^\circ$$

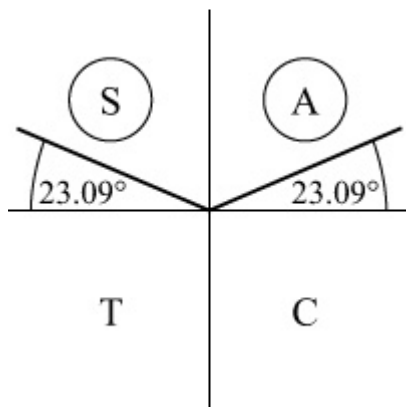

$$\Rightarrow 2x + 78.7^\circ = 156.9^\circ, 383.1^\circ, 516.9^\circ, 743.1^\circ$$

$$\Rightarrow 2x = 78.2^\circ, 304.4^\circ, 438.2^\circ, 664.4^\circ$$

$$\Rightarrow x = 39.1^\circ, 152.2^\circ, 219.1^\circ, 332.2^\circ$$

(b)  $\cot \theta + 2 = \operatorname{cosec} \theta, 0 < \theta < 360^\circ, \theta \neq 180^\circ$

$$\Rightarrow \frac{\cos \theta}{\sin \theta} + 2 = \frac{1}{\sin \theta} \quad (\text{as } \sin \theta \neq 0)$$

$$\Rightarrow \cos \theta + 2 \sin \theta = 1$$

Let  $\cos \theta + 2 \sin \theta \equiv R \cos (\theta - \alpha) \equiv R \cos \theta \cos \alpha + R \sin \theta \sin \alpha$

Compare  $\cos \theta$ :  $R \cos \alpha = 1$  ①

Compare  $\sin \theta$ :  $R \sin \alpha = 2$  ②

Divide ② by ①:  $\tan \alpha = 2 \Rightarrow \alpha = 63.43^\circ$

$$R^2 = 2^2 + 1^2 \Rightarrow R = \sqrt{5}$$

Solve  $\sqrt{5} \cos (\theta - 63.43^\circ) = 1, 0 < \theta < 360^\circ$

$$\Rightarrow \cos (\theta - 63.43^\circ) = \frac{1}{\sqrt{5}}, -63.43^\circ < \theta - 63.43^\circ < 296.6^\circ$$

$$\Rightarrow \theta - 63.43^\circ = 63.43^\circ$$

$$\Rightarrow \theta = 126.9^\circ$$

(c)  $\sin \theta = 2 \cos \theta - \sec \theta, 0 \leq \theta \leq 180^\circ$

$$\Rightarrow \sin \theta \cos \theta = 2 \cos^2 \theta - 1 \quad (\times \cos \theta)$$

$$\Rightarrow \frac{1}{2} \sin 2\theta = \cos 2\theta$$

$$\Rightarrow \tan 2\theta = 2, 0 \leq 2\theta \leq 360^\circ$$

$$\Rightarrow 2\theta = \tan^{-1} 2, 180^\circ + \tan^{-1} 2 = 63.43^\circ, 243.43^\circ$$

$$\Rightarrow \theta = 31.7^\circ, 121.7^\circ$$

(d)  $\sqrt{2} \cos \left( \theta - \frac{\pi}{4} \right) + (\sqrt{3} - 1) \sin \theta$

$$\equiv \sqrt{2} \left( \cos \theta \cos \frac{\pi}{4} + \sin \theta \sin \frac{\pi}{4} \right) + (\sqrt{3} - 1) \sin \theta$$

$$\equiv \cos \theta + \sin \theta + \sqrt{3} \sin \theta - \sin \theta$$

$$\equiv \cos \theta + \sqrt{3} \sin \theta$$

Let  $\cos \theta + \sqrt{3} \sin \theta \equiv R \cos (\theta - \alpha) \equiv R \cos \theta \cos \alpha + R \sin \theta \sin \alpha$

Compare  $\cos \theta$ :  $R \cos \alpha = 1$  ①

Compare  $\sin \theta$ :  $R \sin \alpha = \sqrt{3}$  ②

Divide ② by ①:  $\tan \alpha = \sqrt{3} \Rightarrow \alpha = \frac{\pi}{3}$



$$R^2 = (\sqrt{3})^2 + 1^2 \Rightarrow R = 2$$

$$\text{Solve } 2 \cos \left( \theta - \frac{\pi}{3} \right) = 2, 0 \leq \theta \leq 2\pi$$

$$\Rightarrow \cos \left( \theta - \frac{\pi}{3} \right) = 1, -\frac{\pi}{3} \leq \theta - \frac{\pi}{3} \leq \frac{5\pi}{3}$$

$$\Rightarrow \theta - \frac{\pi}{3} = 0$$

$$\Rightarrow \theta = \frac{\pi}{3}$$

# Solutionbank

## Edexcel AS and A Level Modular Mathematics

### Exercise D, Question 14

#### Question:

Solve, if possible, in the interval  $0 < \theta < 360^\circ$ ,  $\theta \neq 180^\circ$ , the equation

$$\frac{4 - 2\sqrt{2}\sin\theta}{1 + \cos\theta} = k \text{ in the case when } k \text{ is equal to:}$$

(a) 4

(b) 2

(c) 1

(d) 0

(e) -1

Give all angles to the nearest  $0.1^\circ$ .

#### Solution:

(a) When  $k = 4$ ,  $4 - 2\sqrt{2}\sin\theta = 4 + 4\cos\theta$

$$\Rightarrow -2\sqrt{2}\sin\theta = 4\cos\theta$$

$$\Rightarrow \tan\theta = -\frac{4}{2\sqrt{2}} = -\sqrt{2}$$

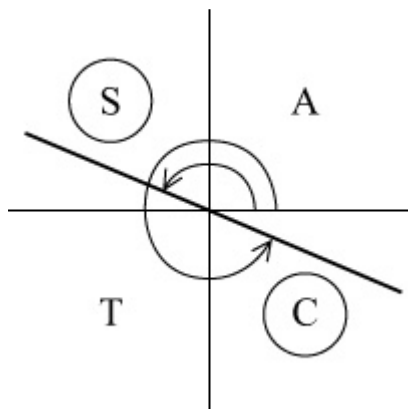

$$\theta = 180^\circ + \tan^{-1}(-\sqrt{2}), 360^\circ + \tan^{-1}(-\sqrt{2}) = 125.3^\circ, 305.3^\circ$$

(b) When  $k = 2$ ,  $4 - 2\sqrt{2}\sin\theta = 2 + 2\cos\theta$

$$\Rightarrow 2\cos\theta + 2\sqrt{2}\sin\theta = 2$$

$$\Rightarrow \cos\theta + \sqrt{2}\sin\theta = 1$$

Using the 'R formula' L.H.S.  $\equiv \sqrt{3}\cos(\theta - 54.74^\circ)$

$$\text{Solve } \sqrt{3} \cos (\theta - 54.74^\circ) = 1$$

$$\Rightarrow \cos \left( \theta - 54.74^\circ \right) = \frac{1}{\sqrt{3}}$$

$$\Rightarrow \theta - 54.74^\circ = 54.74^\circ$$

$$\Rightarrow \theta = 109.5^\circ$$

(c) When  $k = 1$ ,  $4 - 2\sqrt{2} \sin \theta = 1 + \cos \theta$

$$\Rightarrow \cos \theta + 2\sqrt{2} \sin \theta = 3$$

Using the  $R$  formula,  $\cos \theta + 2\sqrt{2} \sin \theta \equiv 3 \cos (\theta - 70.53^\circ)$

$$\text{Solve } 3 \cos (\theta - 70.53^\circ) = 3$$

$$\Rightarrow \cos (\theta - 70.53^\circ) = 1$$

$$\Rightarrow \theta - 70.53^\circ = 0^\circ$$

$$\Rightarrow \theta = 70.5^\circ$$

(d) When  $k = 0$ ,  $4 - 2\sqrt{2} \sin \theta = 0$

$$\Rightarrow \sin \theta = \sqrt{2}$$

No solutions as  $-1 \leq \sin \theta \leq 1$

(e) When  $k = -1$ ,  $4 - 2\sqrt{2} \sin \theta = -1 - \cos \theta$

$$\Rightarrow \cos \theta - 2\sqrt{2} \sin \theta = -5$$

Using the  $R$  formula,  $\cos \theta - 2\sqrt{2} \sin \theta \equiv 3 \cos (\theta + 70.53^\circ)$

This lies between  $-3$  and  $+3$ , so there can be no solutions.

# Solutionbank

## Edexcel AS and A Level Modular Mathematics

### Exercise D, Question 15

#### Question:

Give all angles to the nearest  $0.1^\circ$  and non-exact values of  $R$  in surd form.

A class were asked to solve  $3 \cos \theta = 2 - \sin \theta$  for  $0 \leq \theta \leq 360^\circ$ . One student expressed the equation in the form  $R \cos (\theta - \alpha) = 2$ , with  $R > 0$  and  $0 < \alpha < 90^\circ$ , and correctly solved the equation.

(a) Find the values of  $R$  and  $\alpha$  and hence find her solutions.

Another student decided to square both sides of the equation and then form a quadratic equation in  $\sin \theta$ .

(b) Show that the correct quadratic equation is  $10 \sin^2 \theta - 4 \sin \theta - 5 = 0$ .

(c) Solve this equation, for  $0 \leq \theta < 360^\circ$ .

(d) Explain why not all of the answers satisfy  $3 \cos \theta = 2 - \sin \theta$ .

#### Solution:

(a) Let  $3 \cos \theta + \sin \theta \equiv R \cos (\theta - \alpha) \equiv R \cos \theta \cos \alpha + R \sin \theta \sin \alpha$

Compare  $\cos \theta$ :  $R \cos \alpha = 3$  ①

Compare  $\sin \theta$ :  $R \sin \alpha = 1$  ②

Divide ② by ①:  $\tan \alpha = \frac{1}{3} \Rightarrow \alpha = 18.43^\circ$

$R^2 = 3^2 + 1^2 = 10 \Rightarrow R = \sqrt{10} = 3.16$

Solve  $\sqrt{10} \cos (\theta - 18.43^\circ) = 2, 0 \leq \theta \leq 360^\circ$

$$\Rightarrow \cos (\theta - 18.43^\circ) = \frac{2}{\sqrt{10}}$$

$$\Rightarrow \theta - 18.43^\circ = 50.77^\circ, 309.23^\circ$$

$$\Rightarrow \theta = 69.2^\circ, 327.7^\circ$$

(b) Squaring  $3 \cos \theta = 2 - \sin \theta$

gives  $9 \cos^2 \theta = 4 + \sin^2 \theta - 4 \sin \theta$

$$\Rightarrow 9(1 - \sin^2 \theta) = 4 + \sin^2 \theta - 4 \sin \theta$$

$$\Rightarrow 10 \sin^2 \theta - 4 \sin \theta - 5 = 0$$

(c)  $10 \sin^2 \theta - 4 \sin \theta - 5 = 0$

$$\Rightarrow \sin \theta = \frac{4 \pm \sqrt{216}}{20}$$

For  $\sin \theta = \frac{4 + \sqrt{216}}{20}$ ,  $\sin \theta$  is +ve, so  $\theta$  is in 1st and 2nd quadrants.

$$\Rightarrow \theta = 69.2^\circ, 180^\circ - 69.2^\circ = 69.2^\circ, 110.8^\circ$$

For  $\sin \theta = \frac{4 - \sqrt{216}}{20}$ ,  $\sin \theta$  is -ve, so  $\theta$  is in 3rd and 4th quadrants.

$$\Rightarrow \theta = 180^\circ - (-32.3^\circ), 360^\circ + (-32.3^\circ) = 212.3^\circ, 327.7^\circ$$

So solutions of quadratic in (b) are  $69.2^\circ, 110.8^\circ, 212.3^\circ, 327.7^\circ$

(d) In squaring the equation, you are also including the solutions to  $3 \cos \theta = -(2 - \sin \theta)$ , which when squared produces the same quadratic.

The extra two solutions satisfying this equation.

# Solutionbank

## Edexcel AS and A Level Modular Mathematics

### Exercise E, Question 1

#### Question:

(a) Show that  $\sin ( A + B ) + \sin ( A - B ) \equiv 2 \sin A \cos B$ .

(b) Deduce that  $\sin P + \sin Q \equiv 2 \sin \left( \frac{P+Q}{2} \right) \cos \left( \frac{P-Q}{2} \right)$ .

(c) Use part (a) to express the following as the sum of two sines:

(i)  $2 \sin 7\theta \cos 2\theta$

(ii)  $2 \sin 12\theta \cos 5\theta$

(d) Use the result in (b) to solve, in the interval  $0 \leq \theta \leq 180^\circ$ ,  $\sin 3\theta + \sin \theta = 0$ .

(e) Prove that  $\frac{\sin 7\theta + \sin \theta}{\sin 5\theta + \sin 3\theta} \equiv \frac{\cos 3\theta}{\cos \theta}$ .

#### Solution:

(a)  $\sin ( A + B ) + \sin ( A - B ) \equiv \sin A \cos B + \cos A \sin B + \sin A \cos B - \cos A \sin B$   
 $\equiv 2 \sin A \cos B$

(b) Let  $P = A + B$  and  $Q = A - B$ , so  $A = \frac{P+Q}{2}$ ,  $B = \frac{P-Q}{2}$

Substitute in (a):  $\sin P + \sin Q \equiv 2 \sin \left( \frac{P+Q}{2} \right) \cos \left( \frac{P-Q}{2} \right)$

(c) (i)  $2 \sin 7\theta \cos 2\theta \equiv \sin ( 7\theta + 2\theta ) + \sin ( 7\theta - 2\theta )$  [from (a)]  
 $\equiv \sin 9\theta + \sin 5\theta$

(ii)  $2 \sin 12\theta \cos 5\theta \equiv \sin ( 12\theta + 5\theta ) + \sin ( 12\theta - 5\theta ) \equiv \sin 17\theta + \sin 7\theta$

(d)  $\sin 3\theta + \sin \theta = 0 \Rightarrow 2 \sin \left( \frac{3\theta + \theta}{2} \right) \cos \left( \frac{3\theta - \theta}{2} \right) = 0$

so  $2 \sin 2\theta \cos \theta = 0$

$\Rightarrow \sin 2\theta = 0$  or  $\cos \theta = 0$

$\sin 2\theta = 0$  in  $0 \leq 2\theta \leq 360^\circ$

$\Rightarrow 2\theta = 0^\circ, 180^\circ, 360^\circ$

$\Rightarrow \theta = 0^\circ, 90^\circ, 180^\circ$

$\cos \theta = 0$  in  $0 \leq \theta \leq 180^\circ \Rightarrow \theta = 90^\circ$

Solution set:  $0^\circ, 90^\circ, 180^\circ$

(e)

$$\frac{\sin 7\theta + \sin \theta}{\sin 5\theta + \sin 3\theta} \equiv \frac{\cancel{2} \sin 4\theta \cos 3\theta}{\cancel{2} \sin 4\theta \cos \theta} [\text{using (b)}] \equiv \frac{\cos 3\theta}{\cos \theta}$$

© Pearson Education Ltd 2008

# Solutionbank

## Edexcel AS and A Level Modular Mathematics

### Exercise E, Question 2

#### Question:

(a) Show that  $\sin(A + B) - \sin(A - B) \equiv 2 \cos A \sin B$ .

(b) Express the following as the difference of two sines:

(i)  $2 \cos 5x \sin 3x$

(ii)  $\cos 2x \sin x$

(iii)  $6 \cos \frac{3}{2}x \sin \frac{1}{2}x$

(c) Using the result in (a) show that  $\sin P - \sin Q \equiv 2 \cos \left( \frac{P+Q}{2} \right) \sin \left( \frac{P-Q}{2} \right)$ .

(d) Deduce that  $\sin 56^\circ - \sin 34^\circ = \sqrt{2} \sin 11^\circ$ .

#### Solution:

(a)  $\sin(A + B) - \sin(A - B) \equiv \sin A \cos B + \cos A \sin B -$   
 $(\sin A \cos B - \cos A \sin B)$   
 $\equiv 2 \cos A \sin B$

(b) (i)  $2 \cos 5x \sin 3x \equiv \sin(5x + 3x) - \sin(5x - 3x) \equiv \sin 8x - \sin 2x$

(ii)  $\cos 2x \sin x \equiv \frac{1}{2} [\sin(2x + x) - \sin(2x - x)] \equiv \frac{1}{2} (\sin 3x - \sin x)$

(iii)  $6 \cos \frac{3}{2}x \sin \frac{1}{2}x \equiv 3 \left[ \sin \left( \frac{3}{2}x + \frac{1}{2}x \right) - \sin \left( \frac{3}{2}x - \frac{1}{2}x \right) \right] \equiv 3$   
 $(\sin 2x - \sin x)$

(c) In (a) let  $P = A + B$  and  $Q = A - B$ , so  $A = \frac{P+Q}{2}$ ,  $B = \frac{P-Q}{2}$

So  $\sin P - \sin Q \equiv 2 \cos \left( \frac{P+Q}{2} \right) \sin \left( \frac{P-Q}{2} \right)$

(d)  $\sin 56^\circ - \sin 34^\circ = 2 \cos \left( \frac{56^\circ + 34^\circ}{2} \right) \sin \left( \frac{56^\circ - 34^\circ}{2} \right)$   
 $= 2 \cos 45^\circ \sin 11^\circ = 2 \times \frac{1}{\sqrt{2}} \sin 11^\circ = \sqrt{2} \sin 11^\circ$



# Solutionbank

## Edexcel AS and A Level Modular Mathematics

### Exercise E, Question 3

#### Question:

(a) Show that  $\cos(A + B) + \cos(A - B) \equiv 2 \cos A \cos B$ .

(b) Express as a sum of cosines (i)  $2 \cos \frac{5\theta}{2} \cos \frac{\theta}{2}$

(ii)  $5 \cos 2x \cos 3x$

(c) Show that  $\cos P + \cos Q \equiv 2 \cos \left( \frac{P+Q}{2} \right) \cos \left( \frac{P-Q}{2} \right)$ .

(d) Prove that  $\frac{\sin 3\theta - \sin \theta}{\cos 3\theta + \cos \theta} \equiv \tan \theta$ .

#### Solution:

(a)  $\cos(A + B) + \cos(A - B) \equiv \cos A \cos B - \sin A \sin B + \cos A \cos B + \sin A \sin B$   
 $\equiv 2 \cos A \cos B$

(b) Hence, using (a),

(i)  $2 \cos \frac{5\theta}{2} \cos \frac{\theta}{2} \equiv \cos \left( \frac{5\theta}{2} + \frac{\theta}{2} \right) + \cos \left( \frac{5\theta}{2} - \frac{\theta}{2} \right) \equiv \cos 3\theta + \cos 2\theta$

(ii)  $5 \cos 2x \cos 3x \equiv \frac{5}{2} (2 \cos 3x \cos 2x)$

$$\equiv \frac{5}{2} [ \cos(3x + 2x) + \cos(3x - 2x) ] \equiv \frac{5}{2}$$

$(\cos 5x + \cos x)$

(c) In (a) let  $P = A + B$ ,  $Q = A - B$ , so  $A = \frac{P+Q}{2}$ ,  $B = \frac{P-Q}{2}$

So  $\cos P + \cos Q \equiv 2 \cos \left( \frac{P+Q}{2} \right) \cos \left( \frac{P-Q}{2} \right)$

...

$$\begin{aligned} \text{L.H.S.} \equiv \frac{\sin 3\theta - \sin \theta}{\cos 3\theta + \cos \theta} &\equiv \frac{\cancel{2} \cos \left( \frac{3\theta + \theta}{2} \right) \sin \left( \frac{3\theta - \theta}{2} \right)}{\cancel{2} \cos \left( \frac{3\theta + \theta}{2} \right) \cos \left( \frac{3\theta - \theta}{2} \right)} \\ &\equiv \tan \theta \end{aligned}$$

# Solutionbank

## Edexcel AS and A Level Modular Mathematics

Exercise E, Question 4

### Question:

- (a) Show that  $\cos(A + B) - \cos(A - B) \equiv -2 \sin A \sin B$ .
- (b) Hence show that  $\cos P - \cos Q \equiv -2 \sin\left(\frac{P+Q}{2}\right) \sin\left(\frac{P-Q}{2}\right)$ .
- (c) Deduce that  $\cos 2\theta - 1 \equiv -2 \sin^2 \theta$ .
- (d) Solve, in the interval  $0 \leq \theta \leq 180^\circ$ ,  $\cos 3\theta + \sin 2\theta - \cos \theta = 0$ .

### Solution:

$$\begin{aligned} \text{(a) } \cos(A + B) - \cos(A - B) &\equiv \cos A \cos B - \sin A \sin B - (\cos A \cos B + \sin A \sin B) \\ &\equiv \cos A \cos B - \sin A \sin B - \cos A \cos B - \sin A \sin B \equiv -2 \sin A \sin B \end{aligned}$$

$$\text{(b) Let } P = A + B, Q = A - B, \text{ so } A = \frac{P+Q}{2}, B = \frac{P-Q}{2}$$

$$\text{then } \cos P - \cos Q \equiv -2 \sin\left(\frac{P+Q}{2}\right) \sin\left(\frac{P-Q}{2}\right)$$

$$\begin{aligned} \text{(c) Let } P = 2\theta, Q = 0 \\ \text{then } \cos 2\theta - \cos 0 &\equiv -2 \sin \theta \sin \theta \\ \Rightarrow \cos 2\theta - 1 &\equiv -2 \sin^2 \theta \end{aligned}$$

$$\text{(d) As } \cos 3\theta - \cos \theta \equiv -2 \sin\left(\frac{3\theta + \theta}{2}\right) \sin\left(\frac{3\theta - \theta}{2}\right)$$

$$\cos 3\theta - \cos \theta \equiv -2 \sin 2\theta \sin \theta$$

$$\text{So } \cos 3\theta + \sin 2\theta - \cos \theta = 0$$

$$\Rightarrow \sin 2\theta - 2 \sin 2\theta \sin \theta = 0$$

$$\Rightarrow \sin 2\theta (1 - 2 \sin \theta) = 0$$

$$\Rightarrow \sin 2\theta = 0 \text{ or } \sin \theta = \frac{1}{2}$$

$$\text{For } \sin \theta = \frac{1}{2}, \theta = 30^\circ, 150^\circ$$

$$\text{For } \sin 2\theta = 0, 2\theta = 0^\circ, 180^\circ, 360^\circ$$

$$\text{So } \theta = 0^\circ, 90^\circ, 180^\circ$$

$$\text{Solution set: } 0^\circ, 30^\circ, 90^\circ, 150^\circ, 180^\circ$$

# Solutionbank

## Edexcel AS and A Level Modular Mathematics

### Exercise E, Question 5

#### Question:

Express the following as a sum or difference of sines or cosines:

(a)  $2 \sin 8x \cos 2x$

(b)  $\cos 5x \cos x$

(c)  $3 \sin x \sin 7x$

(d)  $\cos 100^\circ \cos 40^\circ$

(e)  $10 \cos \frac{3x}{2} \sin \frac{x}{2}$

(f)  $2 \sin 30^\circ \cos 10^\circ$

#### Solution:

$$\begin{aligned} \text{(a) } 2 \sin 8x \cos 2x &\equiv \sin (8x + 2x) + \sin (8x - 2x) \\ &\equiv \sin 10x + \sin 6x \quad [\text{question 1(a)}] \end{aligned}$$

$$\begin{aligned} \text{(b) } \cos 5x \cos x &\equiv \frac{1}{2} (2 \cos 5x \cos x) \quad [\text{question 3(a)}] \\ &\equiv \frac{1}{2} [ \cos (5x + x) + \cos (5x - x) ] \equiv \frac{1}{2} \\ &\quad ( \cos 6x + \cos 4x ) \end{aligned}$$

$$\begin{aligned} \text{(c) } 3 \sin x \sin 7x &\equiv - \frac{3}{2} ( - 2 \sin 7x \sin x ) \quad [\text{question 4(a)}] \\ &\equiv - \frac{3}{2} [ \cos (7x + x) - \cos (7x - x) ] \equiv - \frac{3}{2} \\ &\quad ( \cos 8x - \cos 6x ) \end{aligned}$$

$$\begin{aligned} \text{(d) } \cos 100^\circ \cos 40^\circ &\equiv \frac{1}{2} ( 2 \cos 100^\circ \cos 40^\circ ) \\ &\equiv \frac{1}{2} [ \cos (100 + 40)^\circ + \cos (100 - 40)^\circ ] \equiv \\ &\quad \frac{1}{2} ( \cos 140^\circ + \cos 60^\circ ) \end{aligned}$$

$$\begin{aligned}
 \text{(e) } 10 \cos \frac{3x}{2} \sin \frac{x}{2} &\equiv 5 \left( 2 \cos \frac{3x}{2} \sin \frac{x}{2} \right) \quad [\text{question 2(a)}] \\
 &\equiv 5 \left[ \sin \left( \frac{3x}{2} + \frac{x}{2} \right) - \sin \left( \frac{3x}{2} - \frac{x}{2} \right) \right] \equiv 5 \left( \right. \\
 &\quad \left. \sin 2x - \sin x \right)
 \end{aligned}$$

$$\begin{aligned}
 \text{(f) } 2 \sin 30^\circ \cos 10^\circ &\equiv \sin (30^\circ + 10^\circ) + \sin (30^\circ - 10^\circ) \\
 &\equiv \sin 40^\circ + \sin 20^\circ
 \end{aligned}$$

# Solutionbank

## Edexcel AS and A Level Modular Mathematics

Exercise E, Question 6

### Question:

Show, without using a calculator, that  $2 \sin 82 \frac{1}{2}^\circ \cos 37 \frac{1}{2}^\circ = \frac{1}{2} \left( \sqrt{3} + \sqrt{2} \right)$ .

### Solution:

$$\begin{aligned}
 2 \sin 82 \frac{1}{2}^\circ \cos 37 \frac{1}{2}^\circ &= \sin \left( 82 \frac{1}{2}^\circ + 37 \frac{1}{2}^\circ \right) + \sin \left( 82 \frac{1}{2}^\circ - 37 \frac{1}{2}^\circ \right) \\
 &= \sin 120^\circ + \sin 45^\circ \\
 &= \sin 60^\circ + \sin 45^\circ \\
 &= \frac{\sqrt{3}}{2} + \frac{\sqrt{2}}{2} \\
 &= \frac{1}{2} \left( \sqrt{3} + \sqrt{2} \right)
 \end{aligned}$$

# Solutionbank

## Edexcel AS and A Level Modular Mathematics

### Exercise E, Question 7

#### Question:

Express, in their simplest form, as a product of sines and/or cosines:

(a)  $\sin 12x + \sin 8x$

(b)  $\cos (x + 2y) - \cos (2y - x)$

(c)  $(\cos 4x + \cos 2x) \sin x$

(d)  $\sin 95^\circ - \sin 5^\circ$

(e)  $\cos \frac{\pi}{15} + \cos \frac{\pi}{12}$

(f)  $\sin 150^\circ + \sin 20^\circ$

#### Solution:

$$\begin{aligned} \text{(a) } \sin 12x + \sin 8x &\equiv 2 \sin \left( \frac{12x + 8x}{2} \right) \cos \left( \frac{12x - 8x}{2} \right) \\ &\equiv 2 \sin 10x \cos 2x \end{aligned}$$

$$\begin{aligned} \text{(b) } \cos (x + 2y) - \cos (2y - x) &\equiv -2 \sin \left[ \frac{(x + 2y) + (2y - x)}{2} \right] \sin \left[ \frac{(x + 2y) - (2y - x)}{2} \right] \\ &\equiv -2 \sin 2y \sin x \end{aligned}$$

$$\begin{aligned} \text{(c) } \cos 4x + \cos 2x &\equiv 2 \cos \left( \frac{4x + 2x}{2} \right) \cos \left( \frac{4x - 2x}{2} \right) \\ &\equiv 2 \cos 3x \cos x \end{aligned}$$

$$\begin{aligned} \text{So } (\cos 4x + \cos 2x) \sin x &\equiv 2 \cos 3x \cos x \sin x \\ &\equiv \cos 3x (2 \sin x \cos x) \equiv \sin 2x \cos 3x \end{aligned}$$

$$\begin{aligned} \text{(d) } \sin 95^\circ - \sin 5^\circ &\equiv 2 \cos \left( \frac{95^\circ + 5^\circ}{2} \right) \sin \left( \frac{95^\circ - 5^\circ}{2} \right) \\ &\equiv 2 \cos 50^\circ \sin 45^\circ \equiv \sqrt{2} \cos 50^\circ \end{aligned}$$

$$\begin{aligned} \text{(e) } \cos \frac{\pi}{15} + \cos \frac{\pi}{12} &\equiv 2 \cos \left( \frac{\frac{\pi}{15} + \frac{\pi}{12}}{2} \right) \cos \left( \frac{\frac{\pi}{15} - \frac{\pi}{12}}{2} \right) \\ &\equiv 2 \cos \frac{9\pi}{120} \cos \left( -\frac{\pi}{120} \right) \equiv 2 \cos \frac{9\pi}{120} \cos \frac{\pi}{120} \end{aligned}$$

$$\begin{aligned} \text{(f) } \sin 150^\circ + \sin 20^\circ &\equiv 2 \sin \left( \frac{150^\circ + 20^\circ}{2} \right) \cos \left( \frac{150^\circ - 20^\circ}{2} \right) \\ &\equiv 2 \sin 85^\circ \cos 65^\circ \end{aligned}$$

© Pearson Education Ltd 2008

# Solutionbank

## Edexcel AS and A Level Modular Mathematics

### Exercise E, Question 8

#### Question:

Using the identity  $\cos P + \cos Q \equiv 2 \cos \left( \frac{P+Q}{2} \right) \cos \left( \frac{P-Q}{2} \right)$ , show that

$$\cos \theta + \cos \left( \theta + \frac{2\pi}{3} \right) + \cos \left( \theta + \frac{4\pi}{3} \right) = 0.$$

#### Solution:

$$\begin{aligned} & \cos \theta + \cos \left( \theta + \frac{2\pi}{3} \right) + \cos \left( \theta + \frac{4\pi}{3} \right) \\ & \equiv \left[ \cos \left( \theta + \frac{4\pi}{3} \right) + \cos \theta \right] + \cos \left( \theta + \frac{2\pi}{3} \right) \\ & \equiv 2 \cos \left[ \frac{\left( \theta + \frac{4\pi}{3} \right) + \theta}{2} \right] \cos \left[ \frac{\left( \theta + \frac{4\pi}{3} \right) - \theta}{2} \right] + \cos \left( \theta + \frac{2\pi}{3} \right) \\ & \equiv 2 \cos \left( \theta + \frac{2\pi}{3} \right) \cos \frac{2\pi}{3} + \cos \left( \theta + \frac{2\pi}{3} \right) \\ & \equiv 2 \cos \left( \theta + \frac{2\pi}{3} \right) \left( -\frac{1}{2} \right) + \cos \left( \theta + \frac{2\pi}{3} \right) \\ & \equiv -\cos \left( \theta + \frac{2\pi}{3} \right) + \cos \left( \theta + \frac{2\pi}{3} \right) \\ & \equiv 0 \end{aligned}$$



# Solutionbank

## Edexcel AS and A Level Modular Mathematics

### Exercise E, Question 9

#### Question:

Prove that  $\frac{\sin 75^\circ + \sin 15^\circ}{\cos 15^\circ - \cos 75^\circ} = \sqrt{3}$ .

#### Solution:

$$\begin{aligned} \sin 75^\circ + \sin 15^\circ &= 2 \sin \left( \frac{75+15}{2} \right)^\circ \cos \left( \frac{75-15}{2} \right)^\circ = 2 \sin 45^\circ \\ \cos 15^\circ - \cos 75^\circ &= -(\cos 75^\circ - \cos 15^\circ) \\ &= - \left[ -2 \sin \left( \frac{75+15}{2} \right)^\circ \sin \left( \frac{75-15}{2} \right)^\circ \right] \\ &= 2 \sin 45^\circ \sin 30^\circ \\ \text{So } \frac{\sin 75^\circ + \sin 15^\circ}{\cos 15^\circ - \cos 75^\circ} &= \frac{2 \sin 45^\circ \cos 30^\circ}{2 \sin 45^\circ \sin 30^\circ} = \cot 30^\circ = \frac{1}{\tan 30^\circ} = \sqrt{3} \end{aligned}$$

# Solutionbank

## Edexcel AS and A Level Modular Mathematics

### Exercise E, Question 10

#### Question:

Solve the following equations:

(a)  $\cos 4x = \cos 2x$ , for  $0 \leq x \leq 180^\circ$

(b)  $\sin 3\theta - \sin \theta = 0$ , for  $0 \leq \theta \leq 2\pi$

(c)  $\sin(x + 20^\circ) + \sin(x - 10^\circ) = \cos 15^\circ$ , for  $0 \leq x \leq 360^\circ$

(d)  $\sin 3\theta - \sin \theta = \cos 2\theta$ , for  $0 \leq \theta \leq 2\pi$

#### Solution:

(a)  $\cos 4x - \cos 2x = 0$

$$\Rightarrow -2 \sin\left(\frac{4x+2x}{2}\right) \sin\left(\frac{4x-2x}{2}\right) = 0$$

$$\Rightarrow \sin 3x \sin x = 0$$

$$\Rightarrow \sin 3x = 0 \text{ or } \sin x = 0, 0 \leq x \leq 180^\circ$$

$$\sin x = 0, 0 \leq x \leq 180^\circ$$

$$\Rightarrow x = 0^\circ, 180^\circ$$

$$\sin 3x = 0, 0 \leq 3x \leq 540^\circ$$

$$\Rightarrow 3x = 0^\circ, 180^\circ, 360^\circ, 540^\circ$$

$$\Rightarrow x = 0^\circ, 60^\circ, 120^\circ, 180^\circ$$

$$\text{Solution set: } 0^\circ, 60^\circ, 120^\circ, 180^\circ$$

(b)  $\sin 3\theta - \sin \theta = 0$

$$\Rightarrow 2 \cos\left(\frac{3\theta+\theta}{2}\right) \sin\left(\frac{3\theta-\theta}{2}\right) = 0$$

$$\Rightarrow 2 \cos 2\theta \sin \theta = 0, 0 \leq \theta \leq 2\pi$$

$$\sin \theta = 0, 0 \leq \theta \leq 2\pi \Rightarrow \theta = 0, \pi, 2\pi$$

$$\cos 2\theta = 0, 0 \leq 2\theta \leq 4\pi$$

$$\Rightarrow 2\theta = \frac{\pi}{2}, \frac{3\pi}{2}, \frac{5\pi}{2}, \frac{7\pi}{2}$$

$$\Rightarrow \theta = \frac{\pi}{4}, \frac{3\pi}{4}, \frac{5\pi}{4}, \frac{7\pi}{4}$$

Solution set:  $0, \frac{\pi}{4}, \frac{3\pi}{4}, \pi, \frac{5\pi}{4}, \frac{7\pi}{4}, 2\pi$

$$(c) \sin \left( x + 20^\circ \right) + \sin \left( x - 10^\circ \right) \equiv 2 \sin \left( \frac{x + 20^\circ + x - 10^\circ}{2} \right) \cos \left[ \frac{x + 20^\circ - (x - 10^\circ)}{2} \right]$$

$$\equiv 2 \sin (x + 5^\circ) \cos 15^\circ$$

$$\text{So } \sin (x + 20^\circ) + \sin (x - 10^\circ) = \cos 15^\circ, 0 \leq x \leq 360^\circ$$

$$\Rightarrow 2 \sin (x + 5^\circ) = 1$$

$$\text{So } \sin \left( x + 5^\circ \right) = \frac{1}{2}, 5^\circ \leq (x + 5^\circ) \leq 365^\circ$$

$$\Rightarrow x + 5^\circ = 30^\circ, 150^\circ$$

$$\Rightarrow x = 25^\circ, 145^\circ$$

$$(d) \sin 3\theta - \sin \theta \equiv 2 \cos \left( \frac{3\theta + \theta}{2} \right) \sin \left( \frac{3\theta - \theta}{2} \right)$$

$$\equiv 2 \cos 2\theta \sin \theta$$

$$\text{So } \sin 3\theta - \sin \theta = \cos 2\theta$$

$$\Rightarrow 2 \cos 2\theta \sin \theta = \cos 2\theta$$

$$\Rightarrow \cos 2\theta (2 \sin \theta - 1) = 0$$

$$\Rightarrow \cos 2\theta = 0 \text{ or } \sin \theta = \frac{1}{2}$$

$$\sin \theta = \frac{1}{2}, 0 \leq \theta \leq 2\pi$$

$$\Rightarrow \theta = \frac{\pi}{6}, \frac{5\pi}{6}$$

$$\cos 2\theta = 0, 0 \leq 2\theta \leq 4\pi$$

$$\Rightarrow 2\theta = \frac{\pi}{2}, \frac{3\pi}{2}, \frac{5\pi}{2}, \frac{7\pi}{2}$$

$$\Rightarrow \theta = \frac{\pi}{4}, \frac{3\pi}{4}, \frac{5\pi}{4}, \frac{7\pi}{4}$$

Solution set:  $\frac{\pi}{6}, \frac{\pi}{4}, \frac{3\pi}{4}, \frac{5\pi}{6}, \frac{5\pi}{4}, \frac{7\pi}{4}$

# Solutionbank

## Edexcel AS and A Level Modular Mathematics

Exercise E, Question 11

### Question:

Prove the identities

$$(a) \frac{\sin 7\theta - \sin 3\theta}{\sin \theta \cos \theta} \equiv 4 \cos 5\theta$$

$$(b) \frac{\cos 2\theta + \cos 4\theta}{\sin 2\theta - \sin 4\theta} \equiv -\cot \theta$$

$$(c) \sin^2(x + y) - \sin^2(x - y) \equiv \sin 2x \sin 2y$$

$$(d) \cos x + 2 \cos 3x + \cos 5x \equiv 4 \cos^2 x \cos 3x$$

### Solution:

$$\begin{aligned}
 (a) \text{ L.H.S.} &\equiv \frac{\sin 7\theta - \sin 3\theta}{\sin \theta \cos \theta} \\
 &\equiv \frac{2 \cos \frac{1}{2}(7\theta + 3\theta) \sin \frac{1}{2}(7\theta - 3\theta)}{\frac{1}{2}(2 \sin \theta \cos \theta)} \\
 &\equiv \frac{2 \cos 5\theta \sin 2\theta}{\frac{1}{2} \sin 2\theta} \\
 &\equiv 4 \cos 5\theta \\
 &\equiv \text{R.H.S.}
 \end{aligned}$$

$$\begin{aligned}
 (b) \text{ L.H.S.} &\equiv \frac{\cos 2\theta + \cos 4\theta}{\sin 2\theta - \sin 4\theta} \\
 &\equiv \frac{2 \cos \frac{1}{2}(4\theta + 2\theta) \cos \frac{1}{2}(4\theta - 2\theta)}{2 \cos \frac{1}{2}(2\theta + 4\theta) \sin \frac{1}{2}(2\theta - 4\theta)} \\
 &\equiv \frac{2 \cos 3\theta \cos \theta}{2 \cos 3\theta \sin(-\theta)}
 \end{aligned}$$

$$\begin{aligned} &\equiv \frac{\cos \theta}{-\sin \theta} \quad [\text{as } \sin(-\theta) \equiv -\sin \theta] \\ &\equiv -\cot \theta \\ &\equiv \text{R.H.S.} \end{aligned}$$

$$\begin{aligned} \text{(c) L.H.S.} &\equiv \sin^2(x+y) - \sin^2(x-y) \\ &\equiv [\sin(x+y) + \sin(x-y)] [\sin(x+y) - \sin(x-y)] \\ &\equiv \left[ 2 \sin \left( \frac{x+y+x-y}{2} \right) \cos \left( \frac{x+y-x+y}{2} \right) \right] \left[ 2 \cos \left( \frac{x+y+x-y}{2} \right) \sin \left( \frac{x+y-x+y}{2} \right) \right] \\ &\equiv (2 \sin x \cos y) (2 \cos x \sin y) \\ &\equiv (2 \sin x \cos x) (2 \sin y \cos y) \\ &\equiv \sin 2x \sin 2y \\ &\equiv \text{R.H.S.} \end{aligned}$$

$$\begin{aligned} \text{(d) L.H.S.} &\equiv \cos x + 2 \cos 3x + \cos 5x \\ &\equiv \cos 5x + \cos x + 2 \cos 3x \\ &\equiv 2 \cos \left( \frac{5x+x}{2} \right) \cos \left( \frac{5x-x}{2} \right) + 2 \cos 3x \\ &\equiv 2 \cos 3x \cos 2x + 2 \cos 3x \\ &\equiv 2 \cos 3x (\cos 2x + 1) \\ &\equiv 2 \cos 3x (2 \cos^2 x - 1 + 1) \quad (\cos 2x \equiv 2 \cos^2 x - 1) \\ &\equiv 2 \cos 3x \times 2 \cos^2 x \\ &\equiv 4 \cos^2 x \cos 3x \\ &\equiv \text{R.H.S.} \end{aligned}$$

# Solutionbank

## Edexcel AS and A Level Modular Mathematics

Exercise E, Question 12

### Question:

(a) Prove that  $\cos \theta + \sin 2\theta - \cos 3\theta \equiv \sin 2\theta (1 + 2 \sin \theta)$ .

(b) Hence solve, for  $0 \leq \theta \leq 2\pi$ ,  $\cos \theta + \sin 2\theta = \cos 3\theta$ .

### Solution:

$$\begin{aligned}
 \text{(a) L.H.S.} &\equiv \cos \theta + \sin 2\theta - \cos 3\theta \\
 &\equiv -(\cos 3\theta - \cos \theta) + \sin 2\theta \\
 &\equiv -\left[ -2 \sin \left( \frac{3\theta + \theta}{2} \right) \sin \left( \frac{3\theta - \theta}{2} \right) \right] + \sin 2\theta \\
 &\equiv 2 \sin 2\theta \sin \theta + \sin 2\theta \\
 &\equiv \sin 2\theta (2 \sin \theta + 1) \\
 &\equiv \text{R.H.S.}
 \end{aligned}$$

(b) So to solve  $\cos \theta + \sin 2\theta = \cos 3\theta$

or  $\cos \theta + \sin 2\theta - \cos 3\theta = 0$

solve  $\sin 2\theta (1 + 2 \sin \theta) = 0$  [using (a)]

Either  $\sin 2\theta = 0$

$$\Rightarrow 2\theta = 0, \pi, 2\pi, 3\pi, 4\pi$$

$$\Rightarrow \theta = 0, \frac{\pi}{2}, \pi, \frac{3\pi}{2}, 2\pi$$

or  $\sin \theta = -\frac{1}{2}$

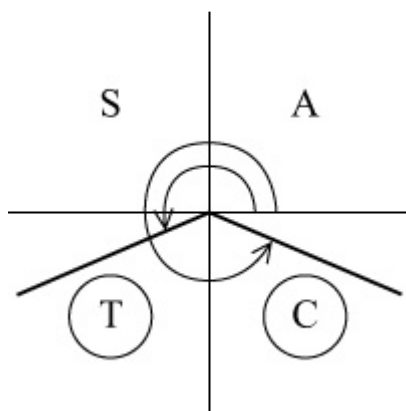

$$\Rightarrow \theta = \pi - \sin^{-1} \left( -\frac{1}{2} \right), 2\pi + \sin^{-1} \left( -\frac{1}{2} \right) = \pi + \frac{\pi}{6}, 2\pi -$$

$$\frac{\pi}{6} = \frac{7\pi}{6}, \frac{11\pi}{6}$$

Solution set:  $0, \frac{\pi}{2}, \pi, \frac{7\pi}{6}, \frac{3\pi}{2}, \frac{11\pi}{6}, 2\pi$

© Pearson Education Ltd 2008

# Solutionbank

## Edexcel AS and A Level Modular Mathematics

### Exercise F, Question 1

#### Question:

The lines  $l_1$  and  $l_2$ , with equations  $y = 2x$  and  $3y = x - 1$  respectively, are drawn on the same set of axes. Given that the scales are the same on both axes and that the angles that  $l_1$  and  $l_2$  make with the positive  $x$ -axis are  $A$  and  $B$  respectively,

- (a) write down the value of  $\tan A$  and the value of  $\tan B$ ;
- (b) without using your calculator, work out the acute angle between  $l_1$  and  $l_2$ .

#### Solution:

(a)  $\tan A = 2$ ,  $\tan B = \frac{1}{3}$  since  $y = \frac{1}{3}x - \frac{1}{3}$

(b) The angle required is  $(A - B)$ .

$$\text{Using } \tan (A - B) = \frac{\tan A - \tan B}{1 + \tan A \tan B} = \frac{2 - \frac{1}{3}}{1 + 2 \times \frac{1}{3}} = \frac{\frac{5}{3}}{\frac{5}{3}} = 1$$

$$\Rightarrow A - B = 45^\circ$$



# Solutionbank

## Edexcel AS and A Level Modular Mathematics

### Exercise F, Question 2

#### Question:

Given that  $\sin x = \frac{1}{\sqrt{5}}$  where  $x$  is acute, and that  $\cos(x - y) = \sin y$ , show that  $\tan y = \frac{\sqrt{5} + 1}{2}$ .

#### Solution:

As  $\cos(x - y) = \sin y$   
 $\cos x \cos y + \sin x \sin y = \sin y$  ①

Draw a right-angled triangle where  $\sin x = \frac{1}{\sqrt{5}}$

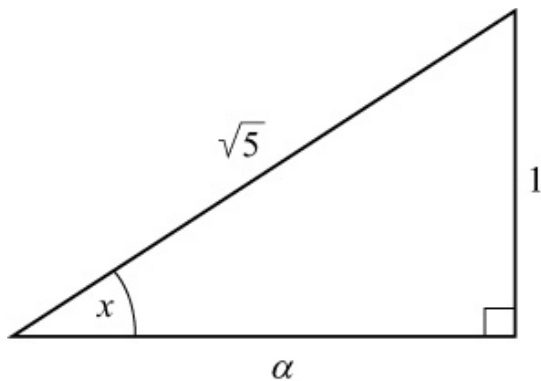

Using Pythagoras' theorem,

$$a^2 = (\sqrt{5})^2 - 1 = 4 \Rightarrow a = 2$$

$$\text{So } \cos x = \frac{2}{\sqrt{5}}$$

Substitute into ①:

$$\frac{2}{\sqrt{5}} \cos y + \frac{1}{\sqrt{5}} \sin y = \sin y$$

$$\Rightarrow 2 \cos y + \sin y = \sqrt{5} \sin y$$

$$\Rightarrow 2 \cos y = \sin y (\sqrt{5} - 1)$$

$$\Rightarrow \frac{2}{\sqrt{5} - 1} = \tan y \quad \left( \tan y = \frac{\sin y}{\cos y} \right)$$

$$\Rightarrow \tan y = \frac{2(\sqrt{5} + 1)}{(\sqrt{5} - 1)(\sqrt{5} + 1)} = \frac{2(\sqrt{5} + 1)}{4} = \frac{\sqrt{5} + 1}{2}$$

# Solutionbank

## Edexcel AS and A Level Modular Mathematics

### Exercise F, Question 3

#### Question:

Using  $\tan 2\theta = \frac{2 \tan \theta}{1 - \tan^2 \theta}$  with an appropriate value of  $\theta$ ,

(a) show that  $\tan \frac{\pi}{8} = \sqrt{2} - 1$ .

(b) Use the result in (a) to find the exact value of  $\tan \frac{3\pi}{8}$ .

#### Solution:

(a) Using  $\tan 2\theta = \frac{2 \tan \theta}{1 - \tan^2 \theta}$  with  $\theta = \frac{\pi}{8}$

$$\Rightarrow \tan \frac{\pi}{4} = \frac{2 \tan \frac{\pi}{8}}{1 - \tan^2 \frac{\pi}{8}}$$

Let  $t = \tan \frac{\pi}{8}$

So  $1 = \frac{2t}{1 - t^2}$

$$\Rightarrow 1 - t^2 = 2t$$

$$\Rightarrow t^2 + 2t - 1 = 0$$

$$\Rightarrow t = \frac{-2 \pm \sqrt{8}}{2} = \frac{-2 \pm 2\sqrt{2}}{2} = -1 \pm \sqrt{2}$$

As  $\frac{\pi}{8}$  is acute,  $\tan \frac{\pi}{8}$  is +ve, so  $\tan \frac{\pi}{8} = \sqrt{2} - 1$

(b)  $\tan \frac{3\pi}{8} = \tan \left( \frac{\pi}{4} + \frac{\pi}{8} \right) = \frac{\tan \frac{\pi}{4} + \tan \frac{\pi}{8}}{1 - \tan \frac{\pi}{4} \tan \frac{\pi}{8}}$

$$= \frac{1 + (\sqrt{2} - 1)}{1 - (\sqrt{2} - 1)} = \frac{\sqrt{2}}{2 - \sqrt{2}} = \frac{\sqrt{2}(2 + \sqrt{2})}{(2 - \sqrt{2})(2 + \sqrt{2})} = \frac{\sqrt{2}}{2}$$

$$(2 + \sqrt{2}) = \sqrt{2} + 1$$

© Pearson Education Ltd 2008

# Solutionbank

## Edexcel AS and A Level Modular Mathematics

### Exercise F, Question 4

#### Question:

In  $\triangle ABC$ ,  $AB = 5$  cm and  $AC = 4$  cm,  $\angle ABC = (\theta - 30)^\circ$  and  $\angle ACB = (\theta + 30)^\circ$ . Using the sine rule, show that  $\tan \theta = 3\sqrt{3}$ .

#### Solution:

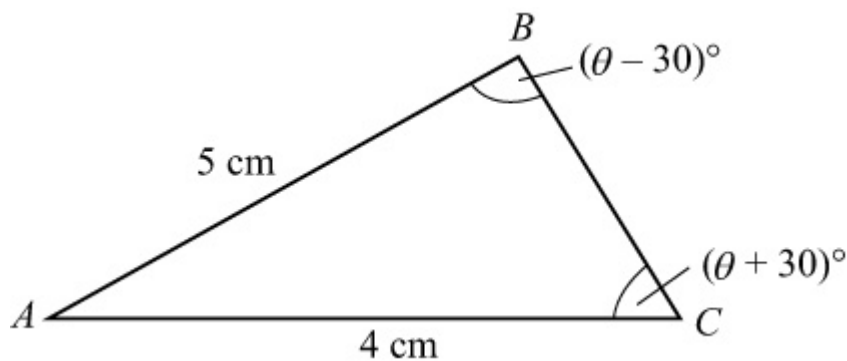

Using  $\frac{\sin B}{b} = \frac{\sin C}{c}$

$$\Rightarrow \frac{\sin(\theta - 30)^\circ}{4} = \frac{\sin(\theta + 30)^\circ}{5}$$

$$\Rightarrow 5 \sin(\theta - 30)^\circ = 4 \sin(\theta + 30)^\circ$$

$$\Rightarrow 5(\sin \theta \cos 30^\circ - \cos \theta \sin 30^\circ) = 4(\sin \theta \cos 30^\circ + \cos \theta \sin 30^\circ)$$

$$\Rightarrow \sin \theta \cos 30^\circ = 9 \cos \theta \sin 30^\circ$$

$$\Rightarrow \frac{\sin \theta}{\cos \theta} = 9 \frac{\sin 30^\circ}{\cos 30^\circ} = 9 \tan 30^\circ$$

$$\Rightarrow \tan \theta = 9 \times \frac{\sqrt{3}}{3} = 3\sqrt{3}$$

# Solutionbank

## Edexcel AS and A Level Modular Mathematics

### Exercise F, Question 5

#### Question:

Two of the angles,  $A$  and  $B$ , in  $\triangle ABC$  are such that  $\tan A = \frac{3}{4}$ ,  $\tan B = \frac{5}{12}$ .

(a) Find the exact value of

(i)  $\sin ( A + B )$

(ii)  $\tan 2B$

(b) By writing  $C$  as  $180^\circ - ( A + B )$ , show that  $\cos C = -\frac{33}{65}$ .

#### Solution:

(a) Draw right-angled triangles.

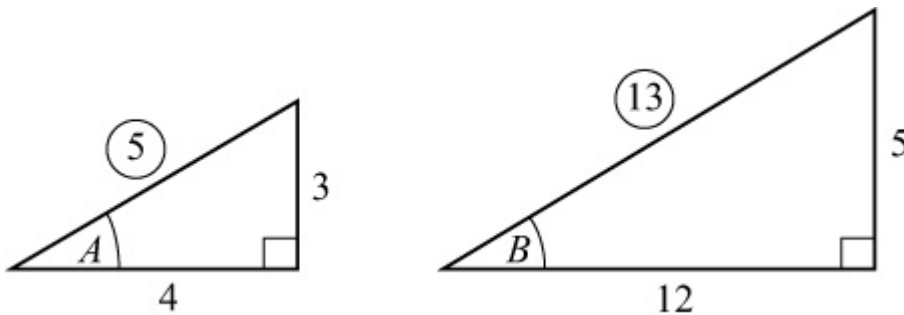

$$\sin A = \frac{3}{5}, \cos A = \frac{4}{5} \quad \sin B = \frac{5}{13}, \cos B = \frac{12}{13}$$

(i)  $\sin ( A + B ) = \sin A \cos B + \cos A \sin B$

$$= \frac{3}{5} \times \frac{12}{13} + \frac{4}{5} \times \frac{5}{13} = \frac{56}{65}$$

(ii)  $\tan 2B = \frac{2 \tan B}{1 - \tan^2 B} = \frac{2 \times \frac{5}{12}}{1 - \left( \frac{5}{12} \right)^2} = \frac{\frac{5}{6}}{\frac{119}{144}} = \frac{5}{6} \times \frac{144}{119} = \frac{120}{119}$

(b)  $\cos C = \cos [ 180^\circ - ( A + B ) ] = -\cos ( A + B )$

$$= - (\cos A \cos B - \sin A \sin B) = - \left( \frac{4}{5} \times \frac{12}{13} - \frac{3}{5} \times \frac{5}{13} \right)$$

= -

© Pearson Education Ltd 2008

# Solutionbank

## Edexcel AS and A Level Modular Mathematics

### Exercise F, Question 6

#### Question:

Show that

$$(a) \sec \theta \operatorname{cosec} \theta \equiv 2 \operatorname{cosec} 2\theta$$

$$(b) \frac{1 - \cos 2x}{1 + \cos 2x} \equiv \sec^2 x - 1$$

$$(c) \cot \theta - 2 \cot 2\theta \equiv \tan \theta$$

$$(d) \cos^4 2\theta - \sin^4 2\theta \equiv \cos 4\theta$$

$$(e) \tan \left( \frac{\pi}{4} + x \right) - \tan \left( \frac{\pi}{4} - x \right) \equiv 2 \tan 2x$$

$$(f) \sin(x + y) \sin(x - y) \equiv \cos^2 y - \cos^2 x$$

$$(g) 1 + 2 \cos 2\theta + \cos 4\theta \equiv 4 \cos^2 \theta \cos 2\theta$$

#### Solution:

$$\begin{aligned} (a) \text{ L.H.S.} &\equiv \sec \theta \operatorname{cosec} \theta \\ &\equiv \frac{1}{\cos \theta} \times \frac{1}{\sin \theta} \\ &\equiv \frac{2}{2 \sin \theta \cos \theta} \\ &\equiv \frac{2}{\sin 2\theta} \\ &\equiv 2 \operatorname{cosec} 2\theta \\ &\equiv \text{R.H.S.} \end{aligned}$$

$$\begin{aligned} (b) \text{ L.H.S.} &\equiv \frac{1 - \cos 2x}{1 + \cos 2x} \\ &\equiv \frac{1 - (1 - 2 \sin^2 x)}{1 + (2 \cos^2 x - 1)} \\ &\equiv \frac{2 \sin^2 x}{2 \cos^2 x} \end{aligned}$$

$$\begin{aligned}
&\equiv \tan^2 x \\
&\equiv \sec^2 x - 1 \quad (1 + \tan^2 x \equiv \sec^2 x) \\
&\equiv \text{R.H.S.}
\end{aligned}$$

$$\begin{aligned}
\text{(c) L.H.S.} &\equiv \cot \theta - 2 \cot 2\theta \\
&\equiv \frac{1}{\tan \theta} - \frac{2}{\tan 2\theta} \\
&\equiv \frac{1}{\tan \theta} - \frac{2(1 - \tan^2 \theta)}{2 \tan \theta} \\
&\equiv \frac{1 - 1 + \tan^2 \theta}{\tan \theta} \\
&\equiv \frac{\tan^2 \theta}{\tan \theta} \\
&\equiv \tan \theta \\
&\equiv \text{R.H.S.}
\end{aligned}$$

$$\begin{aligned}
\text{(d) L.H.S.} &\equiv \cos^4 2\theta - \sin^4 2\theta \\
&\equiv (\cos^2 2\theta + \sin^2 2\theta) (\cos^2 2\theta - \sin^2 2\theta) \\
&\equiv (1) (\cos 4\theta) \quad (\cos^2 A + \sin^2 A \equiv 1, \\
&\cos^2 A - \sin^2 A \equiv \cos 2A) \\
&\equiv \cos 4\theta \\
&\equiv \text{R.H.S.}
\end{aligned}$$

$$\begin{aligned}
\text{(e) L.H.S.} &\equiv \tan \left( \frac{\pi}{4} + x \right) - \tan \left( \frac{\pi}{4} - x \right) \\
&\equiv \frac{1 + \tan x}{1 - \tan x} - \frac{1 - \tan x}{1 + \tan x} \\
&\equiv \frac{(1 + \tan x)^2 - (1 - \tan x)^2}{(1 - \tan x)(1 + \tan x)} \\
&\equiv \frac{1 + 2 \tan x + \tan^2 x - (1 - 2 \tan x + \tan^2 x)}{1 - \tan^2 x} \\
&\equiv \frac{4 \tan x}{1 - \tan^2 x} \\
&\equiv 2 \left( \frac{2 \tan x}{1 - \tan^2 x} \right) \\
&\equiv 2 \tan 2x \\
&\equiv \text{R.H.S.}
\end{aligned}$$

$$\text{(f) R.H.S.} \equiv \cos^2 y - \cos^2 x$$



$$\begin{aligned}
&\equiv (\cos y + \cos x) (\cos y - \cos x) \\
&\equiv \left[ 2 \cos \left( \frac{x+y}{2} \right) \cos \left( \frac{x-y}{2} \right) \right] \left[ -2 \sin \left( \frac{x+y}{2} \right) \right. \\
&\sin \left. \left( \frac{y-x}{2} \right) \right] \\
&\equiv \left[ 2 \cos \left( \frac{x+y}{2} \right) \cos \left( \frac{x-y}{2} \right) \right] \left[ 2 \sin \left( \frac{x+y}{2} \right) \sin \left( \frac{x-y}{2} \right) \right] \\
&\quad [\text{as } \sin(-\theta) = -\sin \theta] \\
&\equiv \left[ 2 \sin \left( \frac{x+y}{2} \right) \cos \left( \frac{x+y}{2} \right) \right] \left[ 2 \sin \left( \frac{x-y}{2} \right) \cos \left( \frac{x-y}{2} \right) \right] \\
&\equiv \sin 2 \left( \frac{x+y}{2} \right) \sin 2 \left( \frac{x-y}{2} \right) \\
&\equiv \sin(x+y) \sin(x-y) \\
&\equiv \text{L.H.S.}
\end{aligned}$$

$$\begin{aligned}
\text{(g) L.H.S.} &\equiv 1 + 2 \cos 2\theta + \cos 4\theta \\
&\equiv 1 + 2 \cos 2\theta + (2 \cos^2 2\theta - 1) \\
&\equiv 2 \cos 2\theta + 2 \cos^2 2\theta \\
&\equiv 2 \cos 2\theta (1 + \cos 2\theta) \\
&\equiv 2 \cos 2\theta [1 + (2 \cos^2 \theta - 1)] \\
&\equiv 4 \cos^2 \theta \cos 2\theta \\
&\equiv \text{R.H.S.}
\end{aligned}$$

# Solutionbank

## Edexcel AS and A Level Modular Mathematics

### Exercise F, Question 7

#### Question:

The angles  $x$  and  $y$  are acute angles such that  $\sin x = \frac{2}{\sqrt{5}}$  and  $\cos y = \frac{3}{\sqrt{10}}$

(a) Show that  $\cos 2x = -\frac{3}{5}$ .

(b) Find the value of  $\cos 2y$ .

(c) Show without using your calculator, that

(i)  $\tan(x + y) = 7$

(ii)  $x - y = \frac{\pi}{4}$

#### Solution:

(a)  $\cos 2x \equiv 1 - 2\sin^2 x = 1 - 2\left(\frac{2}{\sqrt{5}}\right)^2 = 1 - \frac{8}{5} = -\frac{3}{5}$

(b)  $\cos 2y \equiv 2\cos^2 y - 1 = 2\left(\frac{3}{\sqrt{10}}\right)^2 - 1 = 2\left(\frac{9}{10}\right) - 1 = \frac{4}{5}$

(c)

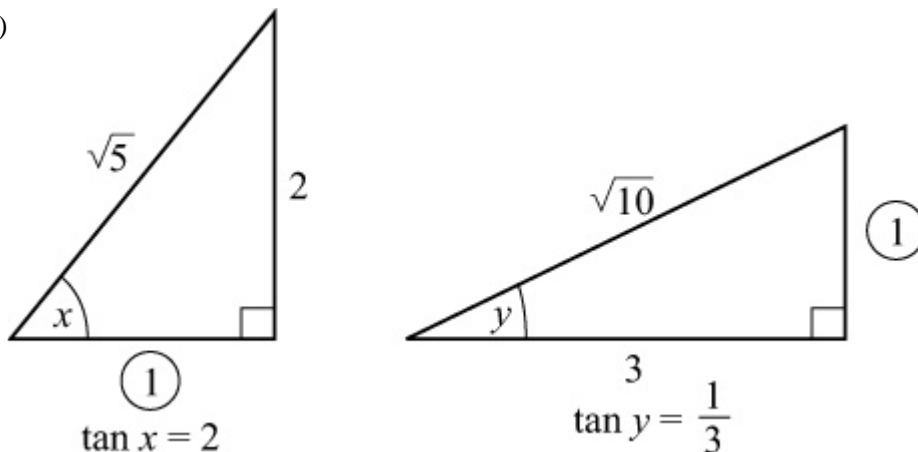

(i)  $\tan(x + y) = \frac{\tan x + \tan y}{1 - \tan x \tan y} = \frac{2\frac{1}{3} + \frac{1}{3}}{1 - 2\frac{1}{3} \cdot \frac{1}{3}} = \frac{\frac{7}{3}}{1 - \frac{2}{3}} = \frac{\frac{7}{3}}{\frac{1}{3}} = 7$

$$(ii) \tan ( x - y ) = \frac{\tan x - \tan y}{1 + \tan x \tan y} = \frac{\frac{5}{3}}{\frac{5}{3}} = 1$$

As  $x$  and  $y$  are acute,  $x - y = \frac{\pi}{4}$  (it cannot be  $\frac{5\pi}{4}$ )

# Solutionbank

## Edexcel AS and A Level Modular Mathematics

### Exercise F, Question 8

#### Question:

Given that  $\sin x \cos y = \frac{1}{2}$  and  $\cos x \sin y = \frac{1}{3}$ ,

(a) show that  $\sin (x + y) = 5 \sin (x - y)$ .

Given also that  $\tan y = k$ , express in terms of  $k$ :

(b)  $\tan x$

(c)  $\tan 2x$

#### Solution:

$$(a) \sin (x + y) \equiv \sin x \cos y + \cos x \sin y = \frac{1}{2} + \frac{1}{3} = \frac{5}{6}$$

$$5 \sin (x - y) \equiv 5 (\sin x \cos y - \cos x \sin y) = 5 \left( \frac{1}{2} - \frac{1}{3} \right) = 5 \times \frac{1}{6} = \frac{5}{6}$$

$$(b) \frac{\sin x \cos y}{\cos x \sin y} = \frac{\frac{1}{2}}{\frac{1}{3}} = \frac{3}{2}$$

$$\Rightarrow \frac{\tan x}{\tan y} = \frac{3}{2}$$

$$\text{so } \tan x = \frac{3}{2} \tan y = \frac{3}{2} k$$

$$(c) \tan 2x = \frac{2 \tan x}{1 - \tan^2 x} = \frac{3k}{1 - \frac{9}{4}k^2} \quad \left( = \frac{12k}{4 - 9k^2} \right)$$

# Solutionbank

## Edexcel AS and A Level Modular Mathematics

### Exercise F, Question 9

#### Question:

Solve the following equations in the interval given in brackets:

(a)  $\sqrt{3} \sin 2\theta + 2 \sin^2 \theta = 1 \quad \{ 0 \leq \theta \leq \pi \}$

(b)  $\sin 3\theta \cos 2\theta = \sin 2\theta \cos 3\theta \quad \{ 0 \leq \theta \leq 2\pi \}$

(c)  $\sin(\theta + 40^\circ) + \sin(\theta + 50^\circ) = 0 \quad \{ 0 \leq \theta \leq 360^\circ \}$

(d)  $\sin^2 \frac{\theta}{2} = 2 \sin \theta \quad \{ 0 \leq \theta \leq 360^\circ \}$

(e)  $2 \sin \theta = 1 + 3 \cos \theta \quad \{ 0 \leq \theta \leq 360^\circ \}$

(f)  $\cos 5\theta = \cos 3\theta \quad \{ 0 \leq \theta \leq \pi \}$

(g)  $\cos 2\theta = 5 \sin \theta \quad \{ -\pi \leq \theta \leq \pi \}$ .

#### Solution:

(a)  $\sqrt{3} \sin 2\theta = 1 - 2 \sin^2 \theta, 0 \leq \theta \leq \pi$

$$\Rightarrow \sqrt{3} \sin 2\theta = \cos 2\theta$$

$$\Rightarrow \tan 2\theta = \frac{1}{\sqrt{3}}, 0 \leq 2\theta \leq 2\pi$$

$$\Rightarrow 2\theta = \frac{\pi}{6}, \pi + \frac{\pi}{6} = \frac{\pi}{6}, \frac{7\pi}{6}$$

$$\Rightarrow \theta = \frac{\pi}{12}, \frac{7\pi}{12}$$

(b)  $\sin 3\theta \cos 2\theta - \cos 3\theta \sin 2\theta = 0$

$$\Rightarrow \sin(3\theta - 2\theta) = 0$$

$$\Rightarrow \sin \theta = 0, 0 \leq \theta \leq 2\pi$$

$$\Rightarrow \theta = 0, \pi, 2\pi$$

(c)  $\sin(\theta + 40^\circ) + \sin(\theta + 50^\circ) = 0, 0 \leq \theta \leq 360^\circ$

$$\Rightarrow 2 \sin \left[ \frac{(\theta + 40^\circ) + (\theta + 50^\circ)}{2} \right] \cos \left[ \frac{(\theta + 40^\circ) - (\theta + 50^\circ)}{2} \right]$$

$$= 0$$

$$\Rightarrow 2 \sin (\theta + 45^\circ) \cos (-5^\circ) = 0$$

$$\Rightarrow \sin (\theta + 45^\circ) = 0, 45^\circ \leq \theta + 45^\circ \leq 405^\circ$$

$$\Rightarrow \theta + 45^\circ = 180^\circ, 360^\circ$$

$$\Rightarrow \theta = 135^\circ, 315^\circ$$

$$(d) \sin^2 \frac{\theta}{2} = 2 \left( 2 \sin \frac{\theta}{2} \cos \frac{\theta}{2} \right) \quad \left( \sin \theta = 2 \sin \frac{\theta}{2} \cos \frac{\theta}{2} \right)$$

$$\Rightarrow \sin \frac{\theta}{2} \left( \sin \frac{\theta}{2} - 4 \cos \frac{\theta}{2} \right) = 0$$

$$\Rightarrow \sin \frac{\theta}{2} = 0 \text{ or } \sin \frac{\theta}{2} = 4 \cos \frac{\theta}{2}, \text{ i.e. } \tan \frac{\theta}{2} = 4$$

$$\text{For } \sin \frac{\theta}{2} = 0 \Rightarrow \frac{\theta}{2} = 0^\circ, 180^\circ \Rightarrow \theta = 0^\circ, 360^\circ$$

$$\text{For } \tan \frac{\theta}{2} = 4 \Rightarrow \frac{\theta}{2} = \tan^{-1} 4 = 75.96^\circ \Rightarrow \theta = 151.9^\circ$$

Solution set:  $0^\circ, 151.9^\circ, 360^\circ$

$$(e) 2 \sin \theta - 3 \cos \theta = 1$$

$$\text{Let } 2 \sin \theta - 3 \cos \theta \equiv R \sin (\theta - \alpha) \equiv R \sin \theta \cos \alpha - R \cos \theta \sin \alpha$$

$$\Rightarrow R \cos \alpha = 2 \text{ and } R \sin \alpha = 3$$

$$\Rightarrow \tan \alpha = \frac{3}{2} \quad (\Rightarrow \alpha = 56.3^\circ), R = \sqrt{13}$$

$$\Rightarrow \sqrt{13} \sin (\theta - 56.3^\circ) = 1$$

$$\Rightarrow \sin (\theta - 56.3^\circ) = \frac{1}{\sqrt{13}}$$

$$\Rightarrow \theta - 56.3^\circ = \sin^{-1} \frac{1}{\sqrt{13}}, 180^\circ - \sin^{-1} \frac{1}{\sqrt{13}} = 16.1^\circ, 163.9^\circ$$

$$\Rightarrow \theta = 72.4^\circ, 220.2^\circ$$

$$(f) \cos 5\theta - \cos 3\theta = 0$$

$$\Rightarrow -2 \sin \left( \frac{5\theta + 3\theta}{2} \right) \sin \left( \frac{5\theta - 3\theta}{2} \right) = 0$$

$$\Rightarrow \sin 4\theta \sin \theta = 0, 0 \leq \theta \leq \pi$$

$$\Rightarrow \sin \theta = 0 \Rightarrow \theta = 0, \pi$$

$$\text{or } \sin 4\theta = 0 \Rightarrow 4\theta = 0, \pi, 2\pi, 3\pi, 4\pi$$

$$\Rightarrow \theta = 0, \frac{\pi}{4}, \frac{\pi}{2}, \frac{3\pi}{4}, \pi$$

Solution set:  $0, \frac{\pi}{4}, \frac{\pi}{2}, \frac{3\pi}{4}, \pi$

(g)  $\cos 2\theta = 5 \sin \theta$

$$\Rightarrow 1 - 2 \sin^2 \theta = 5 \sin \theta$$

$$\Rightarrow 2 \sin^2 \theta + 5 \sin \theta - 1 = 0$$

$$\Rightarrow \sin \theta = \frac{-5 \pm \sqrt{33}}{4}$$

As  $-1 \leq \sin \theta \leq 1$ ,  $\sin \theta = \frac{-5 + \sqrt{33}}{4}$

In radian mode:  $\theta = 0.187, \pi - 0.187 = 0.187, 2.95$

# Solutionbank

## Edexcel AS and A Level Modular Mathematics

Exercise F, Question 10

### Question:

The first three terms of an arithmetic series are  $\sqrt{3} \cos \theta$ ,  $\sin (\theta - 30^\circ)$  and  $\sin \theta$ , where  $\theta$  is acute. Find the value of  $\theta$ .

### Solution:

As the three values are consecutive terms of an arithmetic progression,

$$\sin (\theta - 30^\circ) - \sqrt{3} \cos \theta = \sin \theta - \sin (\theta - 30^\circ)$$

$$\Rightarrow 2 \sin (\theta - 30^\circ) = \sin \theta + \sqrt{3} \cos \theta$$

$$\Rightarrow 2 (\sin \theta \cos 30^\circ - \cos \theta \sin 30^\circ) = \sin \theta + \sqrt{3} \cos \theta$$

$$\Rightarrow \sqrt{3} \sin \theta - \cos \theta = \sin \theta + \sqrt{3} \cos \theta$$

$$\Rightarrow \sin \theta (\sqrt{3} - 1) = \cos \theta (\sqrt{3} + 1)$$

$$\Rightarrow \tan \theta = \frac{\sqrt{3} + 1}{\sqrt{3} - 1}$$

Calculator value is  $\theta = \tan^{-1} \frac{\sqrt{3} + 1}{\sqrt{3} - 1} = 75^\circ$

No other values as  $\theta$  is acute.



# Solutionbank

## Edexcel AS and A Level Modular Mathematics

### Exercise F, Question 11

#### Question:

Solve, for  $0 \leq \theta \leq 360^\circ$ ,  $\cos(\theta + 40^\circ) \cos(\theta - 10^\circ) = 0.5$ .

#### Solution:

$$\begin{aligned}
 2 \cos(\theta + 40^\circ) \cos(\theta - 10^\circ) &= 1 \\
 \Rightarrow \cos \left[ \left( \theta + 40^\circ \right) + \left( \theta - 10^\circ \right) \right] + \cos \left[ \left( \theta + 40^\circ \right) \right. \\
 &\left. - \left( \theta - 10^\circ \right) \right] = 1 \\
 \Rightarrow \cos(2\theta + 30^\circ) + \cos 50^\circ &= 1 \\
 \Rightarrow \cos(2\theta + 30^\circ) &= 1 - \cos 50^\circ = 0.3572 \\
 \Rightarrow 2\theta + 30^\circ &= 69.07^\circ, 290.9^\circ, 429.07^\circ, 650.9^\circ \\
 \Rightarrow 2\theta &= 39.07^\circ, 260.9^\circ, 399.07^\circ, 620.9^\circ \\
 \Rightarrow \theta &= 19.5^\circ, 130.5^\circ, 199.5^\circ, 310.5^\circ
 \end{aligned}$$

# Solutionbank

## Edexcel AS and A Level Modular Mathematics

### Exercise F, Question 12

#### Question:

Without using calculus, find the maximum and minimum value of the following expressions. In each case give the smallest positive value of  $\theta$  at which each occurs.

(a)  $\sin \theta \cos 10^\circ - \cos \theta \sin 10^\circ$

(b)  $\cos 30^\circ \cos \theta - \sin 30^\circ \sin \theta$

(c)  $\sin \theta + \cos \theta$

#### Solution:

(a)  $\sin \theta \cos 10^\circ - \cos \theta \sin 10^\circ = \sin (\theta - 10^\circ)$  [  $\sin (A - B)$  ]

Maximum value = + 1 when  $\theta - 10^\circ = 90^\circ \Rightarrow \theta = 100^\circ$

Minimum value = - 1 when  $\theta - 10^\circ = 270^\circ \Rightarrow \theta = 280^\circ$

(b)  $\cos 30^\circ \cos \theta - \sin 30^\circ \sin \theta = \cos (\theta + 30^\circ)$

Maximum value = + 1 when  $\theta + 30^\circ = 360^\circ \Rightarrow \theta = 330^\circ$

Minimum value = - 1 when  $\theta + 30^\circ = 180^\circ \Rightarrow \theta = 150^\circ$

(c)  $\sin \theta + \cos \theta$

$$= \sqrt{2} \left( \frac{1}{\sqrt{2}} \sin \theta + \frac{1}{\sqrt{2}} \cos \theta \right)$$

$$= \sqrt{2} (\sin \theta \cos 45^\circ + \cos \theta \sin 45^\circ)$$

$$= \sqrt{2} \sin (\theta + 45^\circ)$$

Maximum value =  $\sqrt{2}$  when  $\theta + 45^\circ = 90^\circ \Rightarrow \theta = 45^\circ$

Minimum value =  $-\sqrt{2}$  when  $\theta + 45^\circ = 270^\circ \Rightarrow \theta = 225^\circ$

# Solutionbank

## Edexcel AS and A Level Modular Mathematics

### Exercise F, Question 13

#### Question:

- (a) Express  $\sin x - \sqrt{3} \cos x$  in the form  $R \sin (x - \alpha)$ , with  $R > 0$  and  $0 < \alpha < 90^\circ$ .
- (b) Hence sketch the graph of  $y = \sin x - \sqrt{3} \cos x$   $\{ -360^\circ \leq x \leq 360^\circ \}$ , giving the coordinates of all points of intersection with the axes.

#### Solution:

(a) Let  $\sin x - \sqrt{3} \cos x \equiv R \sin (x - \alpha) \equiv R \sin x \cos \alpha - R \cos x \sin \alpha$   
 $R > 0, 0 < \alpha < 90^\circ$

Compare  $\sin x$ :  $R \cos \alpha = 1$  ①

Compare  $\cos x$ :  $R \sin \alpha = \sqrt{3}$  ②

Divide ② by ①:  $\tan \alpha = \sqrt{3} \Rightarrow \alpha = 60^\circ$

$R^2 = (\sqrt{3})^2 + 1^2 = 4 \Rightarrow R = 2$

So  $\sin x - \sqrt{3} \cos x \equiv 2 \sin (x - 60^\circ)$

- (b) Sketch  $y = 2 \sin (x - 60^\circ)$  by first translating  $y = \sin x$  by  $60^\circ$  to the right and then stretching the result in the  $y$  direction by scale factor 2.

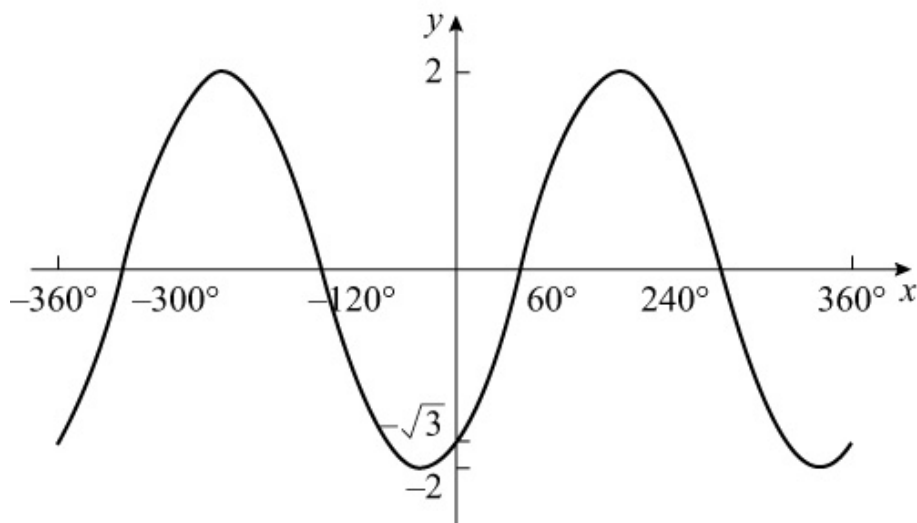

Graph meets  $y$ -axis when  $x = 0$ , i.e.  $y = 2 \sin (-60^\circ) = -\sqrt{3}$

Graph meets  $x$ -axis when  $y = 0$ , i.e.  $(-300^\circ, 0), (-120^\circ, 0), (60^\circ, 0), (240^\circ, 0)$

# Solutionbank

## Edexcel AS and A Level Modular Mathematics

### Exercise F, Question 14

#### Question:

Given that  $7 \cos 2\theta + 24 \sin 2\theta \equiv R \cos (2\theta - \alpha)$ , where  $R > 0$  and  $0 < \alpha < \frac{\pi}{2}$ , find:

- (a) the value of  $R$  and the value of  $\alpha$ , to 2 decimal places  
 (b) the maximum value of  $14 \cos^2 \theta + 48 \sin \theta \cos \theta$

#### Solution:

(a) Let  $7 \cos 2\theta + 24 \sin 2\theta \equiv R \cos (2\theta - \alpha) \equiv R \cos 2\theta \cos \alpha + R \sin 2\theta \sin \alpha$

$$R > 0, 0 < \alpha < \frac{\pi}{2}$$

$$\text{Compare } \cos 2\theta : \quad R \cos \alpha = 7 \quad \textcircled{1}$$

$$\text{Compare } \sin 2\theta : \quad R \sin \alpha = 24 \quad \textcircled{2}$$

$$\text{Divide } \textcircled{2} \text{ by } \textcircled{1}: \quad \tan \alpha = \frac{24}{7} \Rightarrow \alpha = 1.29 \quad (1.287)$$

$$R^2 = 24^2 + 7^2 \Rightarrow R = 25$$

$$\text{So } 7 \cos 2\theta + 24 \sin 2\theta \equiv 25 \cos (2\theta - 1.29)$$

(b)  $14 \cos^2 \theta + 48 \sin \theta \cos \theta$

$$\equiv 14 \left( \frac{1 + \cos 2\theta}{2} \right) + 24 (2 \sin \theta \cos \theta)$$

$$\equiv 7 (1 + \cos 2\theta) + 24 \sin 2\theta$$

$$\equiv 7 + 7 \cos 2\theta + 24 \sin 2\theta$$

The maximum value of  $7 \cos 2\theta + 24 \sin 2\theta$  is 25 [using (a) with  $\cos (2\theta - 1.29) = 1$ ].

So maximum value of  $7 + 7 \cos 2\theta + 24 \sin 2\theta = 7 + 25 = 32$ .

# Solutionbank

## Edexcel AS and A Level Modular Mathematics

### Exercise F, Question 15

#### Question:

(a) Given that  $\alpha$  is acute and  $\tan \alpha = \frac{3}{4}$ , prove that

$$3 \sin (\theta + \alpha) + 4 \cos (\theta + \alpha) \equiv 5 \cos \theta$$

(b) Given that  $\sin x = 0.6$  and  $\cos x = -0.8$ , evaluate  $\cos (x + 270)^\circ$  and  $\cos (x + 540)^\circ$ .

[E]

#### Solution:

(a) Draw a right-angled triangle and find  $\sin \alpha$  and  $\cos \alpha$ .

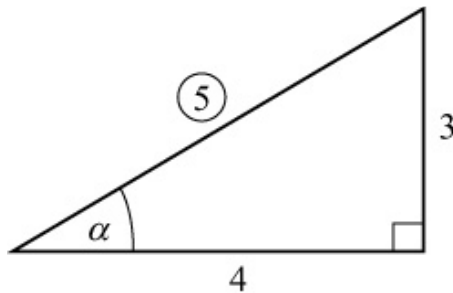

$$\Rightarrow \sin \alpha = \frac{3}{5}, \cos \alpha = \frac{4}{5}$$

So  $3 \sin (\theta + \alpha) + 4 \cos (\theta + \alpha)$

$$\equiv 3 (\sin \theta \cos \alpha + \cos \theta \sin \alpha) + 4 (\cos \theta \cos \alpha - \sin \theta \sin \alpha)$$

$$\equiv 3 \left( \frac{4}{5} \sin \theta + \frac{3}{5} \cos \theta \right) + 4 \left( \frac{4}{5} \cos \theta - \frac{3}{5} \sin \theta \right)$$

$$\equiv \frac{12}{5} \sin \theta + \frac{9}{5} \cos \theta + \frac{16}{5} \cos \theta - \frac{12}{5} \sin \theta$$

$$\equiv \frac{25}{5} \cos \theta$$

$$\equiv 5 \cos \theta$$

$$\begin{aligned} \text{(b) } \cos (x + 270)^\circ &\equiv \cos x^\circ \cos 270^\circ - \sin x^\circ \sin 270^\circ \\ &= (-0.8)(0) - (0.6)(-1) = 0 + 0.6 = 0.6 \end{aligned}$$

$$\begin{aligned} \cos (x + 540)^\circ &\equiv \cos x^\circ \cos 540^\circ - \sin x^\circ \sin 540^\circ \\ &= (-0.8)(-1) - (0.6)(0) = 0.8 - 0 = 0.8 \end{aligned}$$

# Solutionbank

## Edexcel AS and A Level Modular Mathematics

### Exercise F, Question 16

#### Question:

(a) Without using a calculator, find the values of:

(i)  $\sin 40^\circ \cos 10^\circ - \cos 40^\circ \sin 10^\circ$

(ii)  $\frac{1}{\sqrt{2}} \cos 15^\circ - \frac{1}{\sqrt{2}} \sin 15^\circ$

(iii)  $\frac{1 - \tan 15^\circ}{1 + \tan 15^\circ}$

(b) Find, to 1 decimal place, the values of  $x$ ,  $0 \leq x \leq 360^\circ$ , which satisfy the equation  $2 \sin x = \cos (x - 60^\circ)$

[E]

#### Solution:

(a) (i)  $\sin 40^\circ \cos 10^\circ - \cos 40^\circ \sin 10^\circ = \sin (40^\circ - 10^\circ) = \sin 30^\circ = \frac{1}{2}$

(ii)  $\frac{1}{\sqrt{2}} \cos 15^\circ - \frac{1}{\sqrt{2}} \sin 15^\circ$   
 $= \cos 45^\circ \cos 15^\circ - \sin 45^\circ \sin 15^\circ = \cos (45^\circ + 15^\circ) = \cos 60^\circ$   
 $= \frac{1}{2}$

(iii)  $\frac{1 - \tan 15^\circ}{1 + \tan 15^\circ} = \frac{\tan 45^\circ - \tan 15^\circ}{1 + \tan 45^\circ \tan 15^\circ}$   
 $= \tan (45^\circ - 15^\circ) = \tan 30^\circ = \frac{\sqrt{3}}{3}$

(b)  $2 \sin x = \cos (x - 60^\circ)$   
 $\Rightarrow 2 \sin x = \cos x \cos 60^\circ + \sin x \sin 60^\circ$   
 $\Rightarrow 2 \sin x = \frac{1}{2} \cos x + \frac{\sqrt{3}}{2} \sin x$   
 $\Rightarrow (4 - \sqrt{3}) \sin x = \cos x$   
 $\Rightarrow \frac{\sin x}{\cos x} = \frac{1}{4 - \sqrt{3}}$   
 $\Rightarrow \tan x = \frac{1}{4 - \sqrt{3}}$

$$\text{So } x = \tan^{-1} \left( \frac{1}{4 - \sqrt{3}} \right), 180^\circ + \tan^{-1} \left( \frac{1}{4 - \sqrt{3}} \right)$$
$$\Rightarrow x = 23.8^\circ, 203.8^\circ$$

© Pearson Education Ltd 2008

# Solutionbank

## Edexcel AS and A Level Modular Mathematics

Exercise F, Question 17

### Question:

(a) Prove, by counter example, that the statement 'sec ( A + B )  $\equiv$  sec A + sec B , for all A and B' is false.

(b) Prove that  $\tan \theta + \cot \theta \equiv 2 \operatorname{cosec} 2\theta$ ,  $\theta \neq \frac{n\pi}{2}$ ,  $n \in \mathbb{Z}$ .

[E]

### Solution:

(a) One example is sufficient to disprove a statement.

E.g.  $A = 60^\circ$ ,  $B = 0^\circ$

$$\sec ( A + B ) = \sec ( 60^\circ + 0^\circ ) = \sec 60^\circ = \frac{1}{\cos 60^\circ} = 2$$

$$\sec A = \sec 60^\circ = \frac{1}{\cos 60^\circ} = 2$$

$$\sec B = \sec 0^\circ = \frac{1}{\cos 0^\circ} = 1$$

So  $\sec ( 60^\circ + 0^\circ ) \neq \sec 60^\circ + \sec 0^\circ$

$\Rightarrow \sec ( A + B ) \equiv \sec A + \sec B$  not true for all values of A, B.

(b) L.H.S.  $\equiv \tan \theta + \cot \theta$

$$\equiv \frac{\sin \theta}{\cos \theta} + \frac{\cos \theta}{\sin \theta}$$

$$\equiv \frac{\sin^2 \theta + \cos^2 \theta}{\sin \theta \cos \theta}$$

$$\equiv \frac{1}{\frac{1}{2} \sin 2\theta} \quad ( \sin^2 \theta + \cos^2 \theta \equiv 1, \sin 2\theta \equiv 2 \sin \theta \cos \theta )$$

$$\equiv \frac{2}{\sin 2\theta}$$

$$\equiv 2 \operatorname{cosec} 2\theta$$

$$\equiv \text{R.H.S.}$$





# Solutionbank

## Edexcel AS and A Level Modular Mathematics

### Exercise F, Question 18

#### Question:

Using the formula  $\cos(A + B) \equiv \cos A \cos B - \sin A \sin B$ :

(a) Show that  $\cos(A - B) - \cos(A + B) \equiv 2 \sin A \sin B$ .

(b) Hence show that  $\cos 2x - \cos 4x \equiv 2 \sin 3x \sin x$ .

(c) Find all solutions in the range  $0 \leq x \leq \pi$  of the equation  $\cos 2x - \cos 4x = \sin x$  giving all your solutions in multiples of  $\pi$  radians.

[E]

#### Solution:

(a)  $\cos(A + B) \equiv \cos A \cos B - \sin A \sin B$

$$\Rightarrow \cos(A - B) \equiv \cos A \cos(-B) - \sin A \sin(-B)$$

$$\equiv \cos A \cos B + \sin A \sin B$$

so  $\cos(A + B) - \cos(A - B) \equiv (\cos A \cos B - \sin A \sin B) - (\cos A \cos B + \sin A \sin B)$

$$\equiv -2 \sin A \sin B$$

(b) Let  $A + B = 2x$ ,  $A - B = 4x$

$$\text{Add: } 2A = 6x \Rightarrow A = 3x$$

$$\text{Subtract: } 2B = -2x \Rightarrow B = -x$$

Using (a)  $\cos 2x - \cos 4x \equiv -2 \sin 3x \sin(-x) \equiv 2 \sin 3x \sin x$

as  $\sin(-x) = -\sin x$

(c) Solve  $2 \sin 3x \sin x = \sin x$

$$\Rightarrow \sin x (2 \sin 3x - 1) = 0$$

$$\Rightarrow \sin x = 0 \text{ or } \sin 3x = \frac{1}{2}$$

$$\sin x = 0 \Rightarrow x = 0, \pi$$

$$\sin 3x = \frac{1}{2}, 0 \leq 3x \leq 3\pi \Rightarrow 3x = \frac{\pi}{6}, \frac{5\pi}{6}, \frac{13\pi}{6}, \frac{17\pi}{6}$$

$$\Rightarrow x = \frac{\pi}{18}, \frac{5\pi}{18}, \frac{13\pi}{18}, \frac{17\pi}{18}$$

Solution set:  $0, \frac{\pi}{18}, \frac{5\pi}{18}, \frac{13\pi}{18}, \frac{17\pi}{18}, \pi$

© Pearson Education Ltd 2008

# Solutionbank

## Edexcel AS and A Level Modular Mathematics

### Exercise F, Question 19

#### Question:

(a) Given that  $\cos ( x + 30^\circ ) = 3 \cos ( x - 30^\circ )$ , prove that  $\tan x = -\frac{\sqrt{3}}{2}$ .

(b) (i) Prove that  $\frac{1 - \cos 2\theta}{\sin 2\theta} = \tan \theta$ .

(ii) Verify that  $\theta = 180^\circ$  is a solution of the equation  $\sin 2\theta = 2 - 2 \cos 2\theta$ .

(iii) Using the result in part (i), or otherwise, find the two other solutions,  $0 < \theta < 360^\circ$ , of the equation  $\sin 2\theta = 2 - 2 \cos 2\theta$ .

[E]

#### Solution:

$$\begin{aligned}
 \text{(a) } \cos ( x + 30^\circ ) &= 3 \cos ( x - 30^\circ ) \\
 \Rightarrow \cos x \cos 30^\circ - \sin x \sin 30^\circ &= 3 ( \cos x \cos 30^\circ + \sin x \sin 30^\circ ) \\
 \Rightarrow -2 \cos x \cos 30^\circ &= 4 \sin x \sin 30^\circ \\
 \Rightarrow -2 \cos x \times \frac{\sqrt{3}}{2} &= 4 \sin x \times \frac{1}{2} \\
 \Rightarrow -\frac{\sqrt{3}}{2} &= \frac{\sin x}{\cos x} \\
 \Rightarrow \tan x &= -\frac{\sqrt{3}}{2}
 \end{aligned}$$

$$\begin{aligned}
 \text{(b) (i) L.H.S.} &\equiv \frac{1 - \cos 2\theta}{\sin 2\theta} \\
 &\equiv \frac{1 - (1 - 2 \sin^2 \theta)}{2 \sin \theta \cos \theta} \\
 &\equiv \frac{2 \sin^2 \theta}{2 \sin \theta \cos \theta} \\
 &\equiv \frac{\sin \theta}{\cos \theta} \\
 &\equiv \tan \theta
 \end{aligned}$$

$$\text{(ii) L.H.S.} = \sin 360^\circ = 0$$

$$\text{R.H.S.} = 2 - 2 \cos 360^\circ = 2 - 2(1) = 0 \checkmark$$

(iii) Using (i) this is equivalent to solving  $\tan \theta = \frac{1}{2}$ .

From (i)  $1 - \cos 2\theta = \sin 2\theta \tan \theta$

So  $\sin 2\theta = 2 - 2 \cos 2\theta \Rightarrow \sin 2\theta = 2 \sin 2\theta \tan \theta$

$\sin 2\theta = 0$  gives  $\theta = 180^\circ$ , so  $\tan \theta = \frac{1}{2} \Rightarrow \theta = 26.6^\circ, 206.6^\circ$

# Solutionbank

## Edexcel AS and A Level Modular Mathematics

### Exercise F, Question 20

#### Question:

- (a) Express  $1.5 \sin 2x + 2 \cos 2x$  in the form  $R \sin (2x + \alpha)$ , where  $R > 0$  and  $0 < \alpha < \frac{\pi}{2}$ , giving your values of  $R$  and  $\alpha$  to 3 decimal places where appropriate.
- (b) Express  $3 \sin x \cos x + 4 \cos^2 x$  in the form  $a \sin 2x + b \cos 2x + c$ , where  $a$ ,  $b$  and  $c$  are constants to be found.
- (c) Hence, using your answer to part (a), deduce the maximum value of  $3 \sin x \cos x + 4 \cos^2 x$ .

[E]

#### Solution:

(a) Let  $1.5 \sin 2x + 2 \cos 2x \equiv R \sin (2x + \alpha) \equiv R \sin 2x \cos \alpha + R \cos 2x \sin \alpha$

$$R > 0, 0 < \alpha < \frac{\pi}{2}$$

Compare  $\sin 2x$ :  $R \cos \alpha = 1.5$  ①

Compare  $\cos 2x$ :  $R \sin \alpha = 2$  ②

Divide ② by ①:  $\tan \alpha = \frac{4}{3} \Rightarrow \alpha = 0.927$

$$R^2 = 2^2 + 1.5^2 \Rightarrow R = 2.5$$

(b)  $3 \sin x \cos x + 4 \cos^2 x \equiv \frac{3}{2} (2 \sin x \cos x) + 4 \left( \frac{1 + \cos 2x}{2} \right)$

$$\equiv \frac{3}{2} \sin 2x + 2 + 2 \cos 2x \equiv \frac{3}{2} \sin 2x + 2 \cos 2x + 2$$

(c) From part (a)  $\frac{3}{2} \sin 2x + 2 \cos 2x \equiv 2.5 \sin (2x + 0.927)$

So maximum value of  $\frac{3}{2} \sin 2x + 2 \cos 2x = 2.5 \times 1 = 2.5$

So maximum value of  $3 \sin x \cos x + 4 \cos^2 x = 2.5 + 2 = 4.5$

# Solutionbank

## Edexcel AS and A Level Modular Mathematics

### Exercise A, Question 1

#### Question:

Differentiate:

(a)  $(1 + 2x)^4$

(b)  $(3 - 2x^2)^{-5}$

(c)  $(3 + 4x)^{\frac{1}{2}}$

(d)  $(6x + x^2)^7$

(e)  $\frac{1}{3 + 2x}$

(f)  $\sqrt{7 - x}$

(g)  $4(2 + 8x)^4$

(h)  $3(8 - x)^{-6}$

#### Solution:

(a) Let  $u = 1 + 2x$ , then  $y = u^4$

$$\frac{du}{dx} = 2 \quad \text{and} \quad \frac{dy}{du} = 4u^3$$

Using the chain rule,

$$\frac{dy}{dx} = \frac{dy}{du} \times \frac{du}{dx} = 4u^3 \times 2 = 8u^3 = 8(1 + 2x)^3$$

(b) Let  $u = 3 - 2x^2$  then  $y = u^{-5}$

$$\frac{du}{dx} = -4x \quad \text{and} \quad \frac{dy}{du} = -5u^{-6}$$

Using the chain rule,

$$\frac{dy}{dx} = \frac{dy}{du} \times \frac{du}{dx} = -5u^{-6} \times -4x = 20xu^{-6} = 20x(3 - 2x^2)^{-6}$$

(c) Let  $u = 3 + 4x$ , then  $y = u^{\frac{1}{2}}$

$$\frac{du}{dx} = 4 \quad \text{and} \quad \frac{dy}{du} = \frac{1}{2}u^{-\frac{1}{2}}$$

Using the chain rule,

$$\frac{dy}{dx} = \frac{dy}{du} \times \frac{du}{dx} = \frac{1}{2}u^{-\frac{1}{2}} \times 4 = 2u^{-\frac{1}{2}} = 2(3 + 4x)^{-\frac{1}{2}}$$

(d) Let  $u = 6x + x^2$ , then  $y = u^7$

$$\frac{du}{dx} = 6 + 2x \quad \text{and} \quad \frac{dy}{du} = 7u^6$$

Using the chain rule,

$$\frac{dy}{dx} = \frac{dy}{du} \times \frac{du}{dx} = 7u^6 \times (6 + 2x) = 7(6 + 2x)(6x + x^2)^6$$

(e) Let  $u = 3 + 2x$ , then  $y = \frac{1}{u} = u^{-1}$

$$\frac{du}{dx} = 2 \quad \text{and} \quad \frac{dy}{du} = -u^{-2}$$

Using the chain rule,

$$\frac{dy}{dx} = \frac{dy}{du} \times \frac{du}{dx} = -u^{-2} \times 2 = -2u^{-2} = \frac{-2}{(3 + 2x)^2}$$

(f) Let  $u = 7 - x$ , then  $y = u^{\frac{1}{2}}$

$$\frac{du}{dx} = -1 \quad \text{and} \quad \frac{dy}{du} = \frac{1}{2}u^{-\frac{1}{2}}$$

Using the chain rule,

$$\frac{dy}{dx} = \frac{dy}{du} \times \frac{du}{dx} = \frac{1}{2}u^{-\frac{1}{2}} \times -1 = -\frac{1}{2}(7 - x)^{-\frac{1}{2}}$$

(g) Let  $u = 2 + 8x$ , then  $y = 4u^4$

$$\frac{du}{dx} = 8 \quad \text{and} \quad \frac{dy}{du} = 16u^3$$

Using the chain rule,

$$\frac{dy}{dx} = \frac{dy}{du} \times \frac{du}{dx} = 16u^3 \times 8 = 128(2 + 8x)^3$$

(h) Let  $u = 8 - x$ , then  $y = 3u^{-6}$

$$\frac{du}{dx} = -1 \quad \text{and} \quad \frac{dy}{du} = -18u^{-7}$$



Using the chain rule,

$$\frac{dy}{dx} = \frac{dy}{du} \times \frac{du}{dx} = -18u^{-7} \times -1 = 18(8-x)^{-7}$$

© Pearson Education Ltd 2008

# Solutionbank

## Edexcel AS and A Level Modular Mathematics

### Exercise A, Question 2

#### Question:

Given that  $y = \frac{1}{(4x + 1)^2}$  find the value of  $\frac{dy}{dx}$  at  $\left(\frac{1}{4}, \frac{1}{4}\right)$ .

#### Solution:

Let  $u = 4x + 1$ , then  $y = u^{-2}$

$$\frac{du}{dx} = 4 \quad \frac{dy}{du} = -2u^{-3}$$

$$\therefore \frac{dy}{dx} = -8u^{-3} = \frac{-8}{(4x + 1)^3}$$

When  $x = \frac{1}{4}$ ,  $\frac{dy}{dx} = -1$

# Solutionbank

## Edexcel AS and A Level Modular Mathematics

Exercise A, Question 3

### Question:

Given that  $y = (5 - 2x)^3$  find the value of  $\frac{dy}{dx}$  at  $(1, 27)$ .

### Solution:

Let  $u = 5 - 2x$ , then  $y = u^3$

$$\frac{du}{dx} = -2 \quad \frac{dy}{du} = 3u^2$$

$$\therefore \frac{dy}{dx} = -6u^2 = -6(5 - 2x)^2$$

When  $x = 1$ ,  $\frac{dy}{dx} = -54$

© Pearson Education Ltd 2008

# Solutionbank

## Edexcel AS and A Level Modular Mathematics

Exercise A, Question 4

### Question:

Find the value of  $\frac{dy}{dx}$  at the point (8, 2) on the curve with equation  $3y^2 - 2y = x$ .

### Solution:

$$x = 3y^2 - 2y$$

$$\frac{dx}{dy} = 6y - 2$$

$$\frac{dy}{dx} = \frac{1}{6y - 2}$$

At (8, 2) the value of  $y$  is 2.

$$\therefore \frac{dy}{dx} = \frac{1}{12 - 2} = \frac{1}{10}$$

# Solutionbank

## Edexcel AS and A Level Modular Mathematics

### Exercise A, Question 5

#### Question:

Find the value of  $\frac{dy}{dx}$  at the point  $\left(2\frac{1}{2}, 4\right)$  on the curve with equation  $y$

$$\frac{1}{2} + y^{-\frac{1}{2}} = x.$$

#### Solution:

$$x = y^{\frac{1}{2}} + y^{-\frac{1}{2}}$$

$$\frac{dx}{dy} = \frac{1}{2}y^{-\frac{1}{2}} - \frac{1}{2}y^{-\frac{3}{2}}$$

$$\frac{dy}{dx} = \frac{1}{\frac{1}{2}y^{-\frac{1}{2}} - \frac{1}{2}y^{-\frac{3}{2}}}$$

At the point  $\left(2\frac{1}{2}, 4\right)$  the value of  $y$  is 4.

$$\therefore \frac{dy}{dx} = \frac{1}{\frac{1}{2}(4)^{-\frac{1}{2}} - \frac{1}{2}(4)^{-\frac{3}{2}}} = \frac{1}{\frac{1}{4} - \frac{1}{16}} = \frac{1}{\frac{3}{16}} = \frac{16}{3} = 5\frac{1}{3}$$

# Solutionbank

## Edexcel AS and A Level Modular Mathematics

### Exercise B, Question 1

#### Question:

Differentiate:

(a)  $x ( 1 + 3x ) ^ 5$

(b)  $2x ( 1 + 3x^2 ) ^ 3$

(c)  $x^3 ( 2x + 6 ) ^ 4$

(d)  $3x^2 ( 5x - 1 ) ^{-1}$

#### Solution:

(a) Let  $y = x ( 1 + 3x ) ^ 5$

Let  $u = x$  and  $v = ( 1 + 3x ) ^ 5$

Then  $\frac{du}{dx} = 1$  and  $\frac{dv}{dx} = 5 \times 3 ( 1 + 3x ) ^ 4$  (using the chain rule)

Now use the product rule.

$$\frac{dy}{dx} = u \frac{dv}{dx} + v \frac{du}{dx}$$

$$\begin{aligned} \therefore \frac{dy}{dx} &= x \times 15 ( 1 + 3x ) ^ 4 + ( 1 + 3x ) ^ 5 \times 1 \\ &= ( 1 + 3x ) ^ 4 ( 15x + 1 + 3x ) \\ &= ( 1 + 3x ) ^ 4 ( 1 + 18x ) \end{aligned}$$

(b) Let  $y = 2x ( 1 + 3x^2 ) ^ 3$

Let  $u = 2x$  and  $v = ( 1 + 3x^2 ) ^ 3$

Then  $\frac{du}{dx} = 2$  and  $\frac{dv}{dx} = 18x ( 1 + 3x^2 ) ^ 2$

Using the product rule,

$$\frac{dy}{dx} = u \frac{dv}{dx} + v \frac{du}{dx}$$

$$\begin{aligned}
 \therefore \frac{dy}{dx} &= 2x \times 18x (1 + 3x^2)^2 + 2(1 + 3x^2)^3 \\
 &= (1 + 3x^2)^2 [36x^2 + 2(1 + 3x^2)] \\
 &= (1 + 3x^2)^2 (42x^2 + 2) \\
 &= 2(1 + 3x^2)^2 (1 + 21x^2)
 \end{aligned}$$

(c) Let  $y = x^3 (2x + 6)^4$

Let  $u = x^3$  and  $v = (2x + 6)^4$

Then  $\frac{du}{dx} = 3x^2$  and  $\frac{dv}{dx} = 8(2x + 6)^3$

Using the product rule,

$$\frac{dy}{dx} = u \frac{dv}{dx} + v \frac{du}{dx}$$

$$\begin{aligned}
 \therefore \frac{dy}{dx} &= x^3 \times 8(2x + 6)^3 + (2x + 6)^4 \times 3x^2 \\
 &= x^2 (2x + 6)^3 [8x + 3(2x + 6)] \\
 &= x^2 (2x + 6)^3 (14x + 18) \\
 &= 2x^2 (2x + 6)^3 (7x + 9)
 \end{aligned}$$

(d) Let  $y = 3x^2 (5x - 1)^{-1}$

Let  $u = 3x^2$  and  $v = (5x - 1)^{-1}$

Then  $\frac{du}{dx} = 6x$  and  $\frac{dv}{dx} = -5(5x - 1)^{-2}$

Using the product rule,

$$\frac{dy}{dx} = u \frac{dv}{dx} + v \frac{du}{dx}$$

$$\begin{aligned}
 \therefore \frac{dy}{dx} &= 3x^2 \times -5(5x - 1)^{-2} + (5x - 1)^{-1} \times 6x \\
 &= -15x^2 (5x - 1)^{-2} + 6x (5x - 1)^{-1} \\
 &= 3x (5x - 1)^{-2} [-5x + 2(5x - 1)] \\
 &= 3x (5x - 2) (5x - 1)^{-2}
 \end{aligned}$$

# Solutionbank

## Edexcel AS and A Level Modular Mathematics

### Exercise B, Question 2

#### Question:

(a) Find the value of  $\frac{dy}{dx}$  at the point (1, 8) on the curve with equation  $y = x^2 (3x - 1)^3$ .

(b) Find the value of  $\frac{dy}{dx}$  at the point (4, 36) on the curve with equation  $y = 3x (2x + 1)^{\frac{1}{2}}$ .

(c) Find the value of  $\frac{dy}{dx}$  at the point  $\left(2, \frac{1}{5}\right)$  on the curve with equation  $y = (x - 1)(2x + 1)^{-1}$ .

#### Solution:

$$(a) y = x^2 (3x - 1)^3$$

$$\text{Let } u = x^2, v = (3x - 1)^3$$

$$\text{Then } \frac{du}{dx} = 2x, \frac{dv}{dx} = 9(3x - 1)^2$$

Use the product rule  $\frac{dy}{dx} = u \frac{dv}{dx} + v \frac{du}{dx}$  to give

$$\frac{dy}{dx} = x^2 \times 9(3x - 1)^2 + (3x - 1)^3 \times 2x$$

$$= x(3x - 1)^2 [9x + 2(3x - 1)]$$

$$= x(3x - 1)^2 (15x - 2) \quad *$$

At the point (1, 8),  $x = 1$ .

Substitute  $x = 1$  into the expression \*.

$$\text{Then } \frac{dy}{dx} = 1 \times 2^2 \times 13 = 52$$

$$(b) y = 3x (2x + 1)^{\frac{1}{2}}$$

$$\text{Let } u = 3x \text{ and } v = (2x + 1)^{\frac{1}{2}}$$

$$\text{Then } \frac{du}{dx} = 3 \text{ and } \frac{dv}{dx} = \frac{1}{2} \times 2(2x + 1)^{-\frac{1}{2}} = (2x + 1)^{-\frac{1}{2}}$$



Use the product rule  $\frac{dy}{dx} = u \frac{dv}{dx} + v \frac{du}{dx}$  to give

$$\begin{aligned}\frac{dy}{dx} &= 3x(2x+1)^{-\frac{1}{2}} + 3(2x+1)^{\frac{1}{2}} \\ &= 3(2x+1)^{-\frac{1}{2}} [x + (2x+1)] \\ &= 3(3x+1)(2x+1)^{-\frac{1}{2}} \quad *\end{aligned}$$

At the point (4, 36),  $x = 4$ .

Substitute  $x = 4$  into \*.

$$\text{Then } \frac{dy}{dx} = 3 \times 13 \times 9^{-\frac{1}{2}} = 3 \times 13 \times \frac{1}{3} = 13$$

$$(c) y = (x-1)(2x+1)^{-1}$$

Let  $u = x-1$  and  $v = (2x+1)^{-1}$

$$\text{Then } \frac{du}{dx} = 1 \text{ and } \frac{dv}{dx} = -2(2x+1)^{-2}$$

Use the product rule  $\frac{dy}{dx} = u \frac{dv}{dx} + v \frac{du}{dx}$  to give

$$\begin{aligned}\frac{dy}{dx} &= -2(x-1)(2x+1)^{-2} + (2x+1)^{-1} \times 1 \\ &= (2x+1)^{-2} [-2x+2 + (2x+1)] \\ &= 3(2x+1)^{-2} \quad *\end{aligned}$$

At the point  $\left(2, \frac{1}{5}\right)$ ,  $x = 2$ .

Substitute  $x = 2$  into \*

$$\text{Then } \frac{dy}{dx} = 3 \times 5^{-2} = \frac{3}{25}$$

# Solutionbank

## Edexcel AS and A Level Modular Mathematics

### Exercise B, Question 3

#### Question:

Find the points where the gradient is zero on the curve with equation  $y = (x - 2)^2 (2x + 3)$ .

#### Solution:

$$y = (x - 2)^2 (2x + 3)$$

$$u = (x - 2)^2 \text{ and } v = (2x + 3)$$

$$\frac{du}{dx} = 2(x - 2) \text{ and } \frac{dv}{dx} = 2$$

Use the product rule  $\frac{dy}{dx} = u \frac{dv}{dx} + v \frac{du}{dx}$  to give

$$\begin{aligned} \frac{dy}{dx} &= (x - 2)^2 \times 2 + 2(x - 2)(2x + 3) \\ &= 2(x - 2)[(x - 2) + 2x + 3] \\ &= 2(x - 2)(3x + 1) \end{aligned}$$

When the gradient is zero,  $\frac{dy}{dx} = 0$

$$\therefore 2(x - 2)(3x + 1) = 0$$

$$\therefore x = 2 \text{ or } x = -\frac{1}{3}$$

Substitute values for  $x$  into  $y = (x - 2)^2 (2x + 3)$ .

When  $x = 2$ ,  $y = 0$ ; when  $x = -\frac{1}{3}$ ,  $y = 12\frac{19}{27}$ .

So points of zero gradient are  $(2, 0)$  and  $(-\frac{1}{3}, 12\frac{19}{27})$ .

# Solutionbank

## Edexcel AS and A Level Modular Mathematics

### Exercise C, Question 1

#### Question:

Differentiate:

(a)  $\frac{5x}{x+1}$

(b)  $\frac{2x}{3x-2}$

(c)  $\frac{x+3}{2x+1}$

(d)  $\frac{3x^2}{(2x-1)^2}$

(e)  $\frac{6x}{(5x+3)^{\frac{1}{2}}}$

#### Solution:

(a) Let  $u = 5x$  and  $v = x + 1$

$$\therefore \frac{du}{dx} = 5 \text{ and } \frac{dv}{dx} = 1$$

Use the quotient rule

$$\frac{dy}{dx} = \frac{v \frac{du}{dx} - u \frac{dv}{dx}}{v^2}$$

to give

$$\frac{dy}{dx} = \frac{(x+1) \times 5 - 5x \times 1}{(x+1)^2} = \frac{5}{(x+1)^2}$$

(b) Let  $u = 2x$  and  $v = 3x - 2$

$$\therefore \frac{du}{dx} = 2 \text{ and } \frac{dv}{dx} = 3$$

Use the quotient rule

$$\frac{dy}{dx} = \frac{v \frac{du}{dx} - u \frac{dv}{dx}}{v^2}$$

to give

$$\frac{dy}{dx} = \frac{(3x-2) \times 2 - 2x \times 3}{(3x-2)^2} = \frac{6x-4-6x}{(3x-2)^2} = \frac{-4}{(3x-2)^2}$$

(c) Let  $u = x + 3$  and  $v = 2x + 1$

$$\therefore \frac{du}{dx} = 1 \text{ and } \frac{dv}{dx} = 2$$

Use the quotient rule

$$\frac{dy}{dx} = \frac{v \frac{du}{dx} - u \frac{dv}{dx}}{v^2}$$

to give

$$\frac{dy}{dx} = \frac{(2x + 1) \times 1 - (x + 3) \times 2}{(2x + 1)^2} = \frac{2x + 1 - 2x - 6}{(2x + 1)^2} = \frac{-5}{(2x + 1)^2}$$

(d) Let  $u = 3x^2$  and  $v = (2x - 1)^2$

$$\therefore \frac{du}{dx} = 6x \text{ and } \frac{dv}{dx} = 4(2x - 1)$$

Use the quotient rule

$$\frac{dy}{dx} = \frac{v \frac{du}{dx} - u \frac{dv}{dx}}{v^2}$$

to give

$$\begin{aligned} \frac{dy}{dx} &= \frac{(2x - 1)^2 \times 6x - 3x^2 \times 4(2x - 1)}{(2x - 1)^4} \\ &= \frac{6x(2x - 1)[(2x - 1) - 2x]}{(2x - 1)^4} \\ &= \frac{-6x}{(2x - 1)^3} \end{aligned}$$

(e) Let  $u = 6x$  and  $v = (5x + 3)^{\frac{1}{2}}$

$$\therefore \frac{du}{dx} = 6 \text{ and } \frac{dv}{dx} = \frac{5}{2}(5x + 3)^{-\frac{1}{2}}$$

Use the quotient rule

$$\frac{dy}{dx} = \frac{v \frac{du}{dx} - u \frac{dv}{dx}}{v^2}$$

to give

$$\begin{aligned} \frac{dy}{dx} &= \frac{(5x + 3)^{\frac{1}{2}} \times 6 - 6x \times \frac{5}{2}(5x + 3)^{-\frac{1}{2}}}{[(5x + 3)^{\frac{1}{2}}]^2} \\ &= \frac{3(5x + 3)^{-\frac{1}{2}} [2(5x + 3) - 5x]}{(5x + 3)} \end{aligned}$$

$$= \frac{3(5x + 3) - \frac{1}{2}(10x + 6 - 5x)}{(5x + 3)}$$

$$= \frac{3(5x + 6)}{(5x + 3) \frac{3}{2}}$$

© Pearson Education Ltd 2008

# Solutionbank

## Edexcel AS and A Level Modular Mathematics

Exercise C, Question 2

### Question:

Find the value of  $\frac{dy}{dx}$  at the point  $\left(1, \frac{1}{4}\right)$  on the curve with equation  $y = \frac{x}{3x+1}$ .

### Solution:

Let  $u = x$  and  $v = 3x + 1$

$$\therefore \frac{du}{dx} = 1 \text{ and } \frac{dv}{dx} = 3$$

Use the quotient rule

$$\frac{dy}{dx} = \frac{v \frac{du}{dx} - u \frac{dv}{dx}}{v^2}$$

to give

$$\frac{dy}{dx} = \frac{(3x+1) \times 1 - x \times 3}{(3x+1)^2} = \frac{1}{(3x+1)^2} \quad *$$

At the point  $\left(1, \frac{1}{4}\right)$ ,  $x = 1$ . Substitute  $x = 1$  into \*.

$$\text{Then } \frac{dy}{dx} = \frac{1}{16}$$

# Solutionbank

## Edexcel AS and A Level Modular Mathematics

Exercise C, Question 3

### Question:

Find the value of  $\frac{dy}{dx}$  at the point (12, 3) on the curve with equation  $y = \frac{x+3}{(2x+1)^{\frac{1}{2}}}$ .

### Solution:

Let  $u = x + 3$  and  $v = (2x + 1)^{\frac{1}{2}}$

$$\therefore \frac{du}{dx} = 1 \text{ and } \frac{dv}{dx} = (2x + 1)^{-\frac{1}{2}}$$

Use the quotient rule

$$\frac{dy}{dx} = \frac{v \frac{du}{dx} - u \frac{dv}{dx}}{v^2}$$

to give

$$\frac{dy}{dx} = \frac{(2x+1)^{\frac{1}{2}} \times 1 - (x+3)(2x+1)^{-\frac{1}{2}}}{(2x+1)^{-1}}$$

$$= \frac{(2x+1)^{-\frac{1}{2}} [(2x+1) - (x+3)]}{(2x+1)^{-1}}$$

$$= (2x+1)^{-\frac{3}{2}} (x-2)$$

At the point (12, 3),  $x = 12$  and

$$\frac{dy}{dx} = (25)^{-\frac{3}{2}} (10) = \frac{10}{125} = \frac{2}{25}$$

# Solutionbank

## Edexcel AS and A Level Modular Mathematics

### Exercise D, Question 1

#### Question:

Differentiate:

(a)  $e^{2x}$

(b)  $e^{-6x}$

(c)  $e^{x+3}$

(d)  $4e^{3x^2}$

(e)  $9e^{3-x}$

(f)  $xe^{2x}$

(g)  $(x^2 + 3)e^{-x}$

(h)  $(3x - 5)e^{x^2}$

(i)  $2x^4e^{1+x}$

(j)  $(9x - 1)e^{3x}$

(k)  $\frac{x}{e^{2x}}$

(l)  $\frac{e^{x^2}}{x}$

(m)  $\frac{e^x}{x+1}$

(n)  $\frac{e^{-2x}}{\sqrt{x+1}}$

#### Solution:

(a) Let  $y = e^{2x}$ , then  $y = e^t$  where  $t = 2x$

$$\therefore \frac{dy}{dt} = e^t \text{ and } \frac{dt}{dx} = 2$$



By the chain rule

$$\frac{dy}{dx} = \frac{dy}{dt} \times \frac{dt}{dx} = 2e^t = 2e^{2x}$$

(b) Let  $y = e^{-6x}$

$$\text{If } y = e^{f(x)} \text{ then } \frac{dy}{dx} = f'(x) e^{f(x)}$$

$$\text{Let } f(x) = -6x, \text{ then } f'(x) = -6$$

$$\therefore \frac{dy}{dx} = -6e^{-6x}$$

(c) Let  $y = e^{x+3}$

$$\text{Let } f(x) = x + 3, \text{ then } f'(x) = 1$$

$$\text{If } y = e^{f(x)} \text{ then } \frac{dy}{dx} = f'(x) e^{f(x)}$$

$$\therefore \frac{dy}{dx} = 1 \times e^{x+3} = e^{x+3}$$

(d) Let  $y = 4e^{3x^2}$

$$\text{Let } f(x) = 3x^2, \text{ then } f'(x) = 6x$$

$$\therefore \frac{dy}{dx} = 4 \times 6xe^{3x^2} = 24xe^{3x^2}$$

(e) Let  $y = 9e^{3-x}$

$$\text{Let } f(x) = 3 - x, \text{ then } f'(x) = -1$$

$$\therefore \frac{dy}{dx} = 9 \times -1 \times e^{3-x} = -9e^{3-x}$$

(f) Let  $y = xe^{2x}$

$$\text{Let } u = x \text{ and } v = e^{2x}$$

$$\therefore \frac{du}{dx} = 1 \text{ and } \frac{dv}{dx} = 2e^{2x}$$

Use product formula.

$$\frac{dy}{dx} = x \times 2e^{2x} + e^{2x} \times 1 = e^{2x} (2x + 1)$$

(g) Let  $y = (x^2 + 3) e^{-x}$

$$\text{Let } u = x^2 + 3 \text{ and } v = e^{-x}$$

$$\therefore \frac{du}{dx} = 2x \text{ and } \frac{dv}{dx} = -e^{-x}$$

Use product formula.

$$\frac{dy}{dx} = (x^2 + 3) (-e^{-x}) + e^{-x} \times 2x = -e^{-x} (x^2 - 2x + 3)$$

(h) Let  $y = (3x - 5) e^{x^2}$

Let  $u = 3x - 5$  and  $v = e^{x^2}$

$$\therefore \frac{du}{dx} = 3 \text{ and } \frac{dv}{dx} = 2xe^{x^2}$$

Use product formula.

$$\frac{dy}{dx} = (3x - 5) \times 2xe^{x^2} + e^{x^2} \times 3 = e^{x^2} (6x^2 - 10x + 3)$$

(i) Let  $y = 2x^4 e^{1+x}$

Let  $u = 2x^4$  and  $v = e^{1+x}$

$$\therefore \frac{du}{dx} = 8x^3 \text{ and } \frac{dv}{dx} = e^{1+x}$$

Use product formula.

$$\frac{dy}{dx} = 2x^4 e^{1+x} + e^{1+x} \times 8x^3 = 2x^3 e^{1+x} (x + 4)$$

(j) Let  $y = (9x - 1) e^{3x}$

Let  $u = 9x - 1$  and  $v = e^{3x}$

$$\therefore \frac{du}{dx} = 9 \text{ and } \frac{dv}{dx} = 3e^{3x}$$

Use product formula.

$$\frac{dy}{dx} = (9x - 1) \times 3e^{3x} + e^{3x} \times 9 = 3e^{3x} (9x + 2)$$

(k) Let  $y = \frac{x}{e^{2x}}$

Let  $u = x$  and  $v = e^{2x}$

$$\therefore \frac{du}{dx} = 1 \text{ and } \frac{dv}{dx} = 2e^{2x}$$

Use quotient rule

$$\frac{dy}{dx} = \frac{v \frac{du}{dx} - u \frac{dv}{dx}}{v^2}$$

$$\frac{dy}{dx} = \frac{e^{2x} \times 1 - x \times 2e^{2x}}{e^{4x}} = e^{-2x} (1 - 2x)$$

(l) Let  $y = \frac{e^{x^2}}{x}$

Let  $u = e^{x^2}$  and  $v = x$

$$\therefore \frac{du}{dx} = 2xe^{x^2} \text{ and } \frac{dv}{dx} = 1$$

Use quotient rule.

$$\frac{dy}{dx} = \frac{x \times 2xe^{x^2} - e^{x^2} \times 1}{x^2} = \frac{e^{x^2}(2x^2 - 1)}{x^2}$$

(m) Let  $y = \frac{e^x}{x+1}$

Let  $u = e^x$  and  $v = x + 1$

$$\therefore \frac{du}{dx} = e^x \text{ and } \frac{dv}{dx} = 1$$

Use quotient rule.

$$\frac{dy}{dx} = \frac{(x+1)e^x - e^x \times 1}{(x+1)^2} = \frac{xe^x}{(x+1)^2}$$

(n) Let  $y = \frac{e^{-2x}}{\sqrt{x+1}}$

Let  $u = e^{-2x}$  and  $v = (x+1)^{\frac{1}{2}}$

$$\therefore \frac{du}{dx} = -2e^{-2x} \text{ and } \frac{dv}{dx} = \frac{1}{2}(x+1)^{-\frac{1}{2}}$$

Use quotient rule.

$$\frac{dy}{dx} = \frac{(x+1)^{\frac{1}{2}}(-2e^{-2x}) - e^{-2x}[\frac{1}{2}(x+1)^{-\frac{1}{2}}]}{[(x+1)^{\frac{1}{2}}]^2}$$

$$= \frac{[-2(x+1)^{\frac{1}{2}} - \frac{1}{2}(x+1)^{-\frac{1}{2}}]e^{-2x}}{x+1}$$

$$= \frac{\frac{1}{2}(x+1)^{-\frac{1}{2}}[-4(x+1) - 1]e^{-2x}}{x+1}$$

$$= \frac{-(4x+5)e^{-2x}}{2(x+1)^{\frac{3}{2}}}$$

# Solutionbank

## Edexcel AS and A Level Modular Mathematics

### Exercise D, Question 2

#### Question:

Find the value of  $\frac{dy}{dx}$  at the point  $\left(1, \frac{1}{e}\right)$  on the curve with equation

$$y = xe^{-x}.$$

#### Solution:

$$y = xe^{-x}$$

Let  $u = x$  and  $v = e^{-x}$

$$\therefore \frac{du}{dx} = 1 \text{ and } \frac{dv}{dx} = -e^{-x}$$

Use the product rule to give

$$\frac{dy}{dx} = x(-e^{-x}) + e^{-x} \times 1 = e^{-x}(1 - x)$$

At  $\left(1, \frac{1}{e}\right)$ ,  $x = 1$ .

$$\therefore \frac{dy}{dx} = 0$$

# Solutionbank

## Edexcel AS and A Level Modular Mathematics

### Exercise D, Question 3

#### Question:

Find the value of  $\frac{dy}{dx}$  at the point (0, 3) on the curve with equation  $y = (2x + 3) e^{2x}$ .

#### Solution:

$$y = (2x + 3) e^{2x}$$

$$\text{Let } u = 2x + 3 \text{ and } v = e^{2x}$$

$$\therefore \frac{du}{dx} = 2 \text{ and } \frac{dv}{dx} = 2e^{2x}$$

Use the product rule.

$$\frac{dy}{dx} = (2x + 3) 2e^{2x} + e^{2x} \times 2 = 2e^{2x} (2x + 3 + 1) = 2e^{2x} (2x + 4)$$

$$= 4e^{2x} \left( x + 2 \right)$$

At the point (0, 3),  $x = 0$ .

$$\therefore \frac{dy}{dx} = 4 \times 2 = 8$$

# Solutionbank

## Edexcel AS and A Level Modular Mathematics

### Exercise D, Question 4

#### Question:

Find the equation of the tangent to the curve  $y = xe^{2x}$  at the point  $\left(\frac{1}{2}, \frac{1}{2}e\right)$ .

#### Solution:

$$y = xe^{2x}$$

$$\therefore \frac{dy}{dx} = x \left( 2e^{2x} \right) + e^{2x} (1) \quad (\text{From the product rule})$$

At the point  $\left(\frac{1}{2}, \frac{1}{2}e\right)$ ,  $x = \frac{1}{2}$ .

$$\therefore \frac{dy}{dx} = e + e = 2e$$

The tangent at  $\left(\frac{1}{2}, \frac{1}{2}e\right)$  has gradient  $2e$ .

Its equation is

$$y - \frac{1}{2}e = 2e \left( x - \frac{1}{2} \right)$$

$$y - \frac{1}{2}e = 2ex - e$$

$$y = 2ex - \frac{1}{2}e$$

# Solutionbank

## Edexcel AS and A Level Modular Mathematics

### Exercise D, Question 5

#### Question:

Find the equation of the tangent to the curve  $y = \frac{e^{\frac{x}{3}}}{x}$  at the point  $\left( 3, \frac{1}{3}e \right)$ .

#### Solution:

$$y = \frac{e^{\frac{x}{3}}}{x}$$

$$\therefore \frac{dy}{dx} = \frac{x \left( \frac{1}{3} \right) e^{\frac{x}{3}} - e^{\frac{x}{3}} \times 1}{x^2} \quad (\text{From the quotient rule})$$

At the point  $\left( 3, \frac{1}{3}e \right)$ ,  $x = 3$ .

$$\therefore \frac{dy}{dx} = \frac{e - e}{9} = 0$$

The tangent at  $\left( 3, \frac{1}{3}e \right)$  has gradient 0.

Its equation is

$$y - \frac{1}{3}e = 0 (x - 3)$$

$$y = \frac{1}{3}e$$

# Solutionbank

## Edexcel AS and A Level Modular Mathematics

### Exercise D, Question 6

#### Question:

Find the coordinates of the turning points on the curve  $y = x^2e^{-x}$ , and determine whether these points are maximum or minimum points.

#### Solution:

$$y = x^2e^{-x}$$

$$\frac{dy}{dx} = x^2 \left( -e^{-x} \right) + e^{-x} (2x) = xe^{-x} (2 - x) \quad (\text{From the product rule})$$

At a turning point on the curve  $\frac{dy}{dx} = 0$ .

$$\therefore xe^{-x} (2 - x) = 0$$

$$\therefore x = 0 \text{ or } x = 2$$

Substitute these values of  $x$  into the equation  $y = x^2e^{-x}$ .

$$\text{When } x = 0, y = 0$$

$$\text{When } x = 2, y = 4e^{-2}$$

The turning points are at  $(0, 0)$  and  $\left( 2, \frac{4}{e^2} \right)$ .

To establish the nature of the points find  $\frac{d^2y}{dx^2}$ .

$$\text{As } \frac{dy}{dx} = xe^{-x} (2 - x) = e^{-x} \left( 2x - x^2 \right)$$

$$\frac{d^2y}{dx^2} = e^{-x} (2 - 2x) + (2x - x^2) (-e^{-x}) = e^{-x} (2 - 4x + x^2)$$

(From the product rule)

$$\text{When } x = 0, \frac{d^2y}{dx^2} = 2 > 0 \quad \therefore (0, 0) \text{ is a } \mathbf{minimum} \text{ point}$$

$$\text{When } x = 2, \frac{d^2y}{dx^2} = -2e^{-2} < 0 \quad \therefore \left( 2, \frac{4}{e^2} \right) \text{ is a } \mathbf{maximum} \text{ point}$$



# Solutionbank

## Edexcel AS and A Level Modular Mathematics

### Exercise D, Question 7

#### Question:

Given that  $y = \frac{e^{3x}}{x}$ , find  $\frac{dy}{dx}$  and  $\frac{d^2y}{dx^2}$ , simplifying your answers.

Use these answers to find the coordinates of the turning point on the curve with equation  $y = \frac{e^{3x}}{x}$ ,  $x > 0$ , and determine the nature of this turning point.

#### Solution:

$$y = \frac{e^{3x}}{x}$$

$$\frac{dy}{dx} = \frac{x(3e^{3x}) - e^{3x} \times 1}{x^2} = \frac{(3x - 1)e^{3x}}{x^2} \quad (\text{From the quotient rule})$$

To determine  $\frac{d^2y}{dx^2}$  use the quotient rule again with

$$\begin{aligned} u &= 3xe^{3x} - e^{3x} \text{ and } v = x^2 \\ \frac{d^2y}{dx^2} &= \frac{x^2(9xe^{3x} + 3e^{3x} - 3e^{3x}) - (3xe^{3x} - e^{3x})(2x)}{x^4} \\ &= \frac{9x^3e^{3x} - 6x^2e^{3x} + 2xe^{3x}}{x^4} \\ &= \frac{xe^{3x}(9x^2 - 6x + 2)}{x^4} \\ &= \frac{e^{3x}(9x^2 - 6x + 2)}{x^3} \end{aligned}$$

At the turning point  $\frac{dy}{dx} = 0$ .

$$\therefore \frac{(3x - 1)e^{3x}}{x^2} = 0$$

$$\therefore x = \frac{1}{3}$$

Substitute  $x = \frac{1}{3}$  into  $y = \frac{e^{3x}}{x}$ .

$$\therefore y = \frac{e}{\frac{1}{3}} = 3e$$

So  $\left(\frac{1}{3}, 3e\right)$  are the coordinates of the point with zero gradient.

To determine the nature of this point, substitute  $x = \frac{1}{3}$  into

$$\frac{d^2y}{dx^2} = \frac{e^{3x}(9x^2 - 6x + 2)}{x^3}$$

$$\text{When } x = \frac{1}{3}, \frac{d^2y}{dx^2} = \frac{e(1 - 2 + 2)}{\frac{1}{27}} = 27e > 0$$

So there is a **minimum** point at  $\left(\frac{1}{3}, 3e\right)$ .

# Solutionbank

## Edexcel AS and A Level Modular Mathematics

### Exercise E, Question 1

#### Question:

Find the function  $f'(x)$  where  $f(x)$  is

(a)  $\ln(x + 1)$

(b)  $\ln 2x$

(c)  $\ln 3x$

(d)  $\ln(5x - 4)$

(e)  $3 \ln x$

(f)  $4 \ln 2x$

(g)  $5 \ln(x + 4)$

(h)  $x \ln x$

(i)  $\frac{\ln x}{x + 1}$

(j)  $\ln(x^2 - 5)$

(k)  $(3 + x) \ln x$

(l)  $e^x \ln x$

#### Solution:

(a)  $f(x) = \ln(x + 1)$

$F(x) = x + 1, f'(x) = 1$

$$\therefore f'(x) = \frac{1}{x + 1}$$

(b)  $f(x) = \ln 2x$

$F(x) = 2x, f'(x) = 2$

$$\therefore f'(x) = \frac{2}{2x} = \frac{1}{x}$$

$$(c) f(x) = \ln 3x$$

$$f'(x) = \frac{3}{3x} = \frac{1}{x}$$

$$(d) f(x) = \ln(5x - 4)$$

$$f'(x) = \frac{5}{5x - 4}$$

$$(e) f(x) = 3 \ln x$$

$$f'(x) = 3 \times \frac{1}{x} = \frac{3}{x}$$

$$(f) f(x) = 4 \ln 2x$$

$$f'(x) = 4 \times \frac{2}{2x} = \frac{4}{x}$$

$$(g) f(x) = 5 \ln(x + 4)$$

$$f'(x) = 5 \times \frac{1}{x + 4} = \frac{5}{x + 4}$$

$$(h) f(x) = x \ln x$$

Use the product rule with  $u = x$  and  $v = \ln x$ .

$$\text{Then } \frac{du}{dx} = 1 \text{ and } \frac{dv}{dx} = \frac{1}{x}$$

$$\therefore f'(x) = x \times \frac{1}{x} + \ln x \times 1 = 1 + \ln x$$

$$(i) f(x) = \frac{\ln x}{x + 1}$$

Use the quotient rule with  $u = \ln x$  and  $v = x + 1$ .

$$\text{Then } \frac{du}{dx} = \frac{1}{x} \text{ and } \frac{dv}{dx} = 1$$

$$\therefore f'(x) = \frac{(x + 1) \left( \frac{1}{x} \right) - \ln x \times 1}{(x + 1)^2} = \frac{x + 1 - x \ln x}{x(x + 1)^2}$$

$$(j) f(x) = \ln(x^2 - 5)$$

$$F(x) = x^2 - 5, \quad f'(x) = 2x$$

$$\text{If } f(x) = \ln F(x) \text{ then } f'(x) = \frac{f'(x)}{F(x)}$$

$$\therefore f'(x) = \frac{2x}{x^2 - 5}$$

$$(k) f(x) = (3 + x) \ln x$$

Use the product rule with  $u = 3 + x$  and  $v = \ln x$ .

$$\text{Then } \frac{du}{dx} = 1 \text{ and } \frac{dv}{dx} = \frac{1}{x}$$

$$\therefore f'(x) = (3 + x) \frac{1}{x} + \ln x = \frac{3 + x}{x} + \ln x$$

$$(l) f(x) = e^x \ln x$$

Use the product rule with  $u = e^x$  and  $v = \ln x$ .

$$\text{Then } \frac{du}{dx} = e^x \text{ and } \frac{dv}{dx} = \frac{1}{x}$$

$$\therefore f'(x) = e^x \times \frac{1}{x} + \ln x \times e^x = e^x \ln x + \frac{e^x}{x}$$

# Solutionbank

## Edexcel AS and A Level Modular Mathematics

### Exercise F, Question 1

#### Question:

Differentiate:

(a)  $y = \sin 5x$

(b)  $y = 2 \sin \frac{1}{2}x$

(c)  $y = 3 \sin^2 x$

(d)  $y = \sin ( 2x + 1 )$

(e)  $y = \sin 8x$

(f)  $y = 6 \sin \frac{2}{3}x$

(g)  $y = \sin^3 x$

(h)  $y = \sin^5 x$

#### Solution:

(a)  $y = \sin 5x$

If  $y = \sin f ( x )$  , then  $\frac{dy}{dx} = f' ( x ) \cos f ( x )$  .

Let  $f ( x ) = 5x$ , then  $f' ( x ) = 5$

$$\therefore \frac{dy}{dx} = 5 \cos 5x$$

(b)  $y = 2 \sin \frac{1}{2}x$

$$\frac{dy}{dx} = 2 \times \left( \frac{1}{2} \cos \frac{1}{2}x \right) = \cos \frac{1}{2}x$$

(c)  $y = 3 \sin^2 x = 3 ( \sin x )^2$

Let  $u = \sin x$ , then  $y = 3u^2$

$$\frac{du}{dx} = \cos x \text{ and } \frac{dy}{du} = 6u$$

From the chain rule

$$\begin{aligned} \frac{dy}{dx} &= \frac{dy}{du} \times \frac{du}{dx} \\ &= 6u \cos x \\ &= 6 \sin x \cos x \\ &= 3 ( 2 \sin x \cos x ) \\ &= 3 \sin 2x \quad (\text{From the double angle formula}) \end{aligned}$$

$$(d) y = \sin ( 2x + 1 )$$

Let  $f ( x ) = 2x + 1$ , then  $f' ( x ) = 2$

$$\therefore \frac{dy}{dx} = 2 \cos ( 2x + 1 )$$

$$(e) y = \sin 8x$$

$$\therefore \frac{dy}{dx} = 8 \cos 8x$$

$$(f) y = 6 \sin \frac{2}{3}x$$

$$\therefore \frac{dy}{dx} = 6 \times \frac{2}{3} \cos \frac{2}{3}x = 4 \cos \frac{2}{3}x$$

$$(g) y = \sin^3 x$$

Let  $u = \sin x$ , then  $y = u^3$

$$\frac{du}{dx} = \cos x \text{ and } \frac{dy}{du} = 3u^2$$

$$\therefore \frac{dy}{dx} = 3u^2 \cos x = 3 \sin^2 x \cos x \quad (\text{From the chain rule})$$

$$(h) y = \sin^5 x$$

Let  $u = \sin x$ , then  $y = u^5$

$$\frac{du}{dx} = \cos x \text{ and } \frac{dy}{du} = 5u^4$$

From the chain rule

$$\frac{dy}{dx} = \frac{dy}{du} \times \frac{du}{dx} = 5u^4 \times \cos x = 5 \sin^4 x \cos x$$

# Solutionbank

## Edexcel AS and A Level Modular Mathematics

### Exercise G, Question 1

#### Question:

Differentiate:

(a)  $y = 2 \cos x$

(b)  $y = \cos^5 x$

(c)  $y = 6 \cos \frac{5}{6}x$

(d)  $y = 4 \cos ( 3x + 2 )$

(e)  $y = \cos 4x$

(f)  $y = 3 \cos^2 x$

(g)  $y = 4 \cos \frac{1}{2}x$

(h)  $y = 3 \cos 2x$

#### Solution:

(a)  $y = 2 \cos x$

$$\therefore \frac{dy}{dx} = -2 \sin x$$

(b)  $y = \cos^5 x$

Let  $u = \cos x$ , then  $y = u^5$

$$\frac{du}{dx} = -\sin x \text{ and } \frac{dy}{du} = 5u^4$$

From the chain rule

$$\frac{dy}{dx} = \frac{dy}{du} \times \frac{du}{dx} = 5u^4 \times ( -\sin x ) = -5 \cos^4 x \sin x$$

(c)  $y = 6 \cos \frac{5}{6}x$

$$\therefore \frac{dy}{dx} = 6 \times -\frac{5}{6} \sin \frac{5}{6}x = -5 \sin \frac{5}{6}x$$



$$(d) y = 4 \cos ( 3x + 2 )$$

$$\therefore \frac{dy}{dx} = 4 \times -3 \sin ( 3x + 2 ) = -12 \sin ( 3x + 2 )$$

$$(e) y = \cos 4x$$

$$\therefore \frac{dy}{dx} = -4 \sin 4x$$

$$(f) y = 3 \cos^2 x$$

$$\text{Let } u = \cos x, \text{ then } y = 3u^2$$

$$\frac{du}{dx} = -\sin x \text{ and } \frac{dy}{du} = 6u$$

From the chain rule

$$\begin{aligned} \frac{dy}{dx} &= \frac{dy}{du} \times \frac{du}{dx} \\ &= 6u ( -\sin x ) \\ &= -6 \cos x \sin x \\ &= -3 ( 2 \sin x \cos x ) \\ &= -3 \sin 2x \quad (\text{From the double angle formula}) \end{aligned}$$

$$(g) y = 4 \cos \frac{1}{2}x$$

$$\therefore \frac{dy}{dx} = 4 \left( -\frac{1}{2} \sin \frac{1}{2}x \right) = -2 \sin \frac{1}{2}x$$

$$(h) y = 3 \cos 2x$$

$$\therefore \frac{dy}{dx} = 3 ( -2 \sin 2x ) = -6 \sin 2x$$

# Solutionbank

## Edexcel AS and A Level Modular Mathematics

### Exercise H, Question 1

#### Question:

Differentiate:

(a)  $y = \tan 3x$

(b)  $y = 4 \tan^3 x$

(c)  $y = \tan ( x - 1 )$

(d)  $y = x^2 \tan \frac{1}{2}x + \tan \left( x - \frac{1}{2} \right)$

#### Solution:

(a)  $y = \tan 3x$

$$\therefore \frac{dy}{dx} = 3 \sec^2 3x$$

(b)  $y = 4 \tan^3 x$

Let  $u = \tan x$ , then  $y = 4u^3$

$$\frac{du}{dx} = \sec^2 x \text{ and } \frac{dy}{du} = 12u^2$$

From the chain rule

$$\frac{dy}{dx} = \frac{dy}{du} \times \frac{du}{dx} = 12u^2 \sec^2 x = 12 \tan^2 x \sec^2 x$$

(c)  $y = \tan ( x - 1 )$

$$\therefore \frac{dy}{dx} = \sec^2 ( x - 1 )$$

(d)  $y = x^2 \tan \frac{1}{2}x + \tan \left( x - \frac{1}{2} \right)$

The first term is a product with  $u = x^2$  and  $v = \tan \frac{1}{2}x$

$$\therefore \frac{du}{dx} = 2x \text{ and } \frac{dv}{dx} = \frac{1}{2} \sec^2 \frac{1}{2}x$$

$$\begin{aligned}\frac{dy}{dx} &= \left[ x^2 \left( \frac{1}{2} \sec^2 \frac{1}{2}x \right) + \tan \frac{1}{2}x \times 2x \right] + \sec^2 \left( x - \frac{1}{2} \right) \\ &= \frac{1}{2}x^2 \sec^2 \frac{1}{2}x + 2x \tan \frac{1}{2}x + \sec^2 \left( x - \frac{1}{2} \right)\end{aligned}$$

© Pearson Education Ltd 2008

# Solutionbank

## Edexcel AS and A Level Modular Mathematics

### Exercise I, Question 1

#### Question:

Differentiate

(a)  $\cot 4x$

(b)  $\sec 5x$

(c)  $\operatorname{cosec} 4x$

(d)  $\sec^2 3x$

(e)  $x \cot 3x$

(f)  $\frac{\sec^2 x}{x}$

(g)  $\operatorname{cosec}^3 2x$

(h)  $\cot^2 (2x - 1)$

#### Solution:

(a)  $y = \cot 4x$

Let  $u = 4x$ , then  $y = \cot u$

$$\frac{du}{dx} = 4 \text{ and } \frac{dy}{du} = -\operatorname{cosec}^2 u$$

$$\therefore \frac{dy}{dx} = -\operatorname{cosec}^2 u \times 4 = -4\operatorname{cosec}^2 4x \quad (\text{From the chain rule})$$

(b)  $y = \sec 5x$

Let  $u = 5x$ , then  $y = \sec u$

$$\frac{du}{dx} = 5 \text{ and } \frac{dy}{du} = \sec u \tan u$$

$$\therefore \frac{dy}{dx} = 5 \sec u \tan u = 5 \sec 5x \tan 5x$$

(c)  $y = \operatorname{cosec} 4x$

Let  $u = 4x$ , then  $y = \operatorname{cosec} u$

$$\frac{du}{dx} = 4 \text{ and } \frac{dy}{du} = -\operatorname{cosec} u \cot u$$

$$\therefore \frac{dy}{dx} = -4 \operatorname{cosec} u \cot u = -4 \operatorname{cosec} 4x \cot 4x$$

(d)  $y = \sec^2 3x$

Let  $u = \sec 3x$ , then  $y = u^2$

$$\frac{du}{dx} = 3 \sec 3x \tan 3x \text{ and } \frac{dy}{du} = 2u$$

From the chain rule

$$\begin{aligned} \frac{dy}{dx} &= \frac{dy}{du} \times \frac{du}{dx} \\ &= 2u \times 3 \sec 3x \tan 3x \\ &= 2 \sec 3x \times 3 \sec 3x \tan 3x \\ &= 6 \sec^2 3x \tan 3x \end{aligned}$$

(e)  $y = x \cot 3x$

This is a product so use the product formula.

Let  $u = x$  and  $v = \cot 3x$

$$\frac{du}{dx} = 1 \text{ and } \frac{dv}{dx} = -3 \operatorname{cosec}^2 3x$$

$$\therefore \frac{dy}{dx} = x ( -3 \operatorname{cosec}^2 3x ) + \cot 3x \times 1 = \cot 3x - 3x \operatorname{cosec}^2 3x$$

(f)  $y = \frac{\sec^2 x}{x}$

This is a quotient so use the quotient rule.

Let  $u = \sec^2 x$  and  $v = x$

$$\frac{du}{dx} = 2 \sec x ( \sec x \tan x ) \text{ and } \frac{dv}{dx} = 1$$

$$\therefore \frac{dy}{dx} = \frac{x ( 2 \sec^2 x \tan x ) - \sec^2 x \times 1}{x^2} = \frac{\sec^2 x ( 2x \tan x - 1 )}{x^2}$$

(g)  $y = \operatorname{cosec}^3 2x$

Let  $u = \operatorname{cosec} 2x$ , then  $y = u^3$

$$\frac{du}{dx} = -2 \operatorname{cosec} 2x \cot 2x \text{ and } \frac{dy}{du} = 3u^2$$

From the chain rule

$$\begin{aligned}\frac{dy}{dx} &= 3u^2 ( - 2 \operatorname{cosec} 2x \cot 2x ) \\ &= - 6 \operatorname{cosec}^2 2x \operatorname{cosec} 2x \cot 2x \\ &= - 6 \operatorname{cosec}^3 2x \cot 2x\end{aligned}$$

$$(h) y = \cot^2 ( 2x - 1 )$$

Let  $u = \cot ( 2x - 1 )$  then  $y = u^2$

$$\frac{du}{dx} = - 2 \operatorname{cosec}^2 ( 2x - 1 ) \quad \text{and} \quad \frac{dy}{du} = 2u$$

From the chain rule

$$\frac{dy}{dx} = 2u [ - 2 \operatorname{cosec}^2 ( 2x - 1 ) ] = - 4 \cot ( 2x - 1 ) \operatorname{cosec}^2 ( 2x - 1 )$$

# Solutionbank

## Edexcel AS and A Level Modular Mathematics

### Exercise J, Question 1

#### Question:

Find the function  $f'(x)$  where  $f(x)$  is

(a)  $\sin 3x$

(b)  $\cos 4x$

(c)  $\tan 5x$

(d)  $\sec 7x$

(e)  $\operatorname{cosec} 2x$

(f)  $\cot 3x$

(g)  $\sin \frac{2x}{5}$

(h)  $\cos \frac{3x}{7}$

(i)  $\tan \frac{2x}{5}$

(j)  $\operatorname{cosec} \frac{x}{2}$

(k)  $\cot \frac{1}{3}x$

(l)  $\sec \frac{3x}{2}$

#### Solution:

(a)  $f(x) = \sin 3x$   
 $f'(x) = 3 \cos 3x$

(b)  $f(x) = \cos 4x$   
 $f'(x) = -4 \sin 4x$

$$(c) f(x) = \tan 5x$$

$$f'(x) = 5 \sec^2 5x$$

$$(d) f(x) = \sec 7x$$

$$f'(x) = 7 \sec 7x \tan 7x$$

$$(e) f(x) = \operatorname{cosec} 2x$$

$$f'(x) = -2 \operatorname{cosec} 2x \cot 2x$$

$$(f) f(x) = \cot 3x$$

$$f'(x) = -3 \operatorname{cosec}^2 3x$$

$$(g) f(x) = \sin \frac{2x}{5}$$

$$f'(x) = \frac{2}{5} \cos \frac{2x}{5}$$

$$(h) f(x) = \cos \frac{3x}{7}$$

$$f'(x) = -\frac{3}{7} \sin \frac{3x}{7}$$

$$(i) f(x) = \tan \frac{2x}{5}$$

$$f'(x) = \frac{2}{5} \sec^2 \frac{2x}{5}$$

$$(j) f(x) = \operatorname{cosec} \frac{x}{2}$$

$$f'(x) = -\frac{1}{2} \operatorname{cosec} \frac{x}{2} \cot \frac{x}{2}$$

$$(k) f(x) = \cot \frac{1}{3}x$$

$$f'(x) = -\frac{1}{3} \operatorname{cosec}^2 \frac{1}{3}x$$

$$(l) f(x) = \sec \frac{3x}{2}$$

$$f'(x) = \frac{3}{2} \sec \frac{3x}{2} \tan \frac{3x}{2}$$





# Solutionbank

## Edexcel AS and A Level Modular Mathematics

### Exercise J, Question 2

#### Question:

Find the function  $f'(x)$  where  $f(x)$  is

(a)  $\sin^2 x$

(b)  $\cos^3 x$

(c)  $\tan^4 x$

(d)  $(\sec x)^{\frac{1}{2}}$

(e)  $\sqrt{\cot x}$

(f)  $\operatorname{cosec}^2 x$

(g)  $\sin^3 x$

(h)  $\cos^4 x$

(i)  $\tan^2 x$

(j)  $\sec^3 x$

(k)  $\cot^3 x$

(l)  $\operatorname{cosec}^4 x$

#### Solution:

(a)  $f(x) = \sin^2 x = (\sin x)^2$

$f'(x) = 2(\sin x)^1 \cos x = 2 \sin x \cos x = \sin 2x$

(b)  $f(x) = \cos^3 x = (\cos x)^3$

$f'(x) = 3(\cos x)^2 (-\sin x) = -3 \cos^2 x \sin x$

(c)  $f(x) = \tan^4 x = (\tan x)^4$

$f'(x) = 4(\tan x)^3 (\sec^2 x) = 4 \tan^3 x \sec^2 x$

$$(d) f(x) = (\sec x)^{\frac{1}{2}}$$

$$f'(x) = \frac{1}{2} (\sec x)^{-\frac{1}{2}} \times \sec x \tan x = \frac{1}{2} (\sec x)^{\frac{1}{2}} \tan x$$

$$(e) f(x) = (\cot x)^{\frac{1}{2}}$$

$$f'(x) = \frac{1}{2} (\cot x)^{-\frac{1}{2}} \times (-\operatorname{cosec}^2 x) = -\frac{1}{2} (\cot x)^{-\frac{1}{2}} \operatorname{cosec}^2 x$$

$$(f) f(x) = \operatorname{cosec}^2 x = (\operatorname{cosec} x)^2$$

$$f'(x) = 2 (\operatorname{cosec} x)^1 (-\operatorname{cosec} x \cot x) = -2 \operatorname{cosec}^2 x \cot x$$

$$(g) f(x) = (\sin x)^3$$

$$f'(x) = 3 (\sin x)^2 \cos x = 3 \sin^2 x \cos x$$

$$(h) f(x) = (\cos x)^4$$

$$f'(x) = 4 (\cos x)^3 (-\sin x) = -4 \cos^3 x \sin x$$

$$(i) f(x) = (\tan x)^2$$

$$f'(x) = 2 \tan x \times \sec^2 x = 2 \tan x \sec^2 x$$

$$(j) f(x) = (\sec x)^3$$

$$f'(x) = 3 (\sec x)^2 \sec x \tan x = 3 \sec^3 x \tan x$$

$$(k) f(x) = (\cot x)^3$$

$$f'(x) = 3 (\cot x)^2 (-\operatorname{cosec}^2 x) = -3 \operatorname{cosec}^2 x \cot^2 x$$

$$(l) f(x) = (\operatorname{cosec} x)^4$$

$$f'(x) = 4 (\operatorname{cosec} x)^3 (-\operatorname{cosec} x \cot x) = -4 \operatorname{cosec}^4 x \cot x$$

# Solutionbank

## Edexcel AS and A Level Modular Mathematics

### Exercise J, Question 3

#### Question:

Find the function  $f'(x)$  where  $f(x)$  is

(a)  $x \cos x$

(b)  $x^2 \sec 3x$

(c)  $\frac{\tan 2x}{x}$

(d)  $\sin^3 x \cos x$

(e)  $\frac{x^2}{\tan x}$

(f)  $\frac{1 + \sin x}{\cos x}$

(g)  $e^{2x} \cos x$

(h)  $e^x \sec 3x$

(i)  $\frac{\sin 3x}{e^x}$

(j)  $e^x \sin^2 x$

(k)  $\frac{\ln x}{\tan x}$

(l)  $\frac{e^{\sin x}}{\cos x}$

#### Solution:

(a)  $f(x) = x \cos x$

$$f'(x) = x(-\sin x) + \cos x(1) \quad (\text{Product rule})$$

$$= -x \sin x + \cos x$$

$$(b) f(x) = x^2 \sec 3x$$

$$f'(x) = x^2 (3 \sec 3x \tan 3x) + \sec 3x (2x) \quad (\text{Product rule})$$

$$= x \sec 3x (3x \tan 3x + 2)$$

$$(c) f(x) = \frac{\tan 2x}{x}$$

$$f'(x) = \frac{x(2 \sec^2 2x) - \tan 2x(1)}{x^2} \quad (\text{Quotient rule})$$

$$= \frac{2x \sec^2 2x - \tan 2x}{x^2}$$

$$(d) f(x) = \sin^3 x \cos x$$

$$f'(x) = \sin^3 x (-\sin x) + \cos x (3 \sin^2 x \cos x) \quad (\text{Product rule})$$

$$= 3 \sin^2 x \cos^2 x - \sin^4 x$$

$$(e) f(x) = \frac{x^2}{\tan x}$$

$$f'(x) = \frac{\tan x (2x) - x^2 (\sec^2 x)}{\tan^2 x} \quad (\text{Quotient rule})$$

$$= \frac{2x \tan x - x^2 \sec^2 x}{\tan^2 x}$$

$$(f) f(x) = \frac{1 + \sin x}{\cos x}$$

$$f'(x) = \frac{\cos x (\cos x) - (1 + \sin x) (-\sin x)}{\cos^2 x} \quad (\text{Quotient rule})$$

$$= \frac{\cos^2 x + \sin x + \sin^2 x}{\cos^2 x}$$

$$= \frac{(\cos^2 x + \sin^2 x) + \sin x}{\cos^2 x} \quad (\text{Use } \cos^2 x + \sin^2 x \equiv 1)$$

$$= \frac{1 + \sin x}{\cos^2 x}$$

$$(g) f(x) = e^{2x} \cos x$$

$$f'(x) = e^{2x} (-\sin x) + \cos x (2e^{2x}) \quad (\text{Product rule})$$

$$= e^{2x} (2 \cos x - \sin x)$$

$$(h) f(x) = e^x \sec 3x$$

$$f'(x) = e^x (3 \sec 3x \tan 3x) + \sec 3x (e^x) \quad (\text{Product rule})$$

$$= e^x \sec 3x (3 \tan 3x + 1)$$

$$(i) f(x) = \frac{\sin 3x}{e^x}$$

$$f'(x) = \frac{e^x (3 \cos 3x) - \sin 3x (e^x)}{(e^x)^2} \quad (\text{Quotient rule})$$

$$= \frac{e^x (3 \cos 3x - \sin 3x)}{(e^x)^2}$$

$$= \frac{3 \cos 3x - \sin 3x}{e^x}$$

$$(j) f(x) = e^x \sin^2 x$$

$$f'(x) = e^x (2 \sin x \cos x) + \sin^2 x (e^x) \quad (\text{Product rule})$$

$$= e^x \sin x (2 \cos x + \sin x)$$

$$(k) f(x) = \frac{\ln x}{\tan x}$$

$$f'(x) = \frac{\tan x \left(\frac{1}{x}\right) - \ln x (\sec^2 x)}{\tan^2 x} \quad (\text{Quotient rule})$$

$$= \frac{\tan x - x \sec^2 x \ln x}{x \tan^2 x} \quad (\text{Multiply numerator and denominator by } x)$$

$$(l) f(x) = \frac{e^{\sin x}}{\cos x}$$

$$f'(x) = \frac{\cos x [e^{\sin x} \times \cos x] - e^{\sin x} (-\sin x)}{\cos^2 x} \quad (\text{Quotient rule})$$

$$= \frac{e^{\sin x} (\cos^2 x + \sin x)}{\cos^2 x}$$

# Solutionbank

## Edexcel AS and A Level Modular Mathematics

### Exercise K, Question 1

#### Question:

Differentiate with respect to  $x$ :

(a)  $\ln x^2$

(b)  $x^2 \sin 3x$

[E]

#### Solution:

(a)  $y = \ln x^2 = 2 \ln x$  (This uses properties of logs)

$$\therefore \frac{dy}{dx} = 2 \times \frac{1}{x} = \frac{2}{x}$$

*Alternative method*

When  $y = \ln f(x)$ ,  $\frac{dy}{dx} = \frac{f'(x)}{f(x)}$  (From the chain rule)

$$\therefore y = \ln x^2 \Rightarrow \frac{dy}{dx} = \frac{2x}{x^2} = \frac{2}{x}$$

(b)  $y = x^2 \sin 3x$

$$\frac{dy}{dx} = x^2 (3 \cos 3x) + \sin 3x (2x) \quad (\text{Product rule})$$

$$= 3x^2 \cos 3x + 2x \sin 3x$$

# Solutionbank

## Edexcel AS and A Level Modular Mathematics

### Exercise K, Question 2

#### Question:

Given that

$$f(x) \equiv 3 - \frac{x^2}{4} + \ln \frac{x}{2}, x > 0$$

find  $f'(x)$ .

[E]

#### Solution:

$$f(x) = 3 - \frac{x^2}{4} + \ln \frac{x}{2}$$

$$f'(x) = 0 - \frac{2x}{4} + \frac{\frac{1}{2}}{\frac{1}{2}x} = -\frac{x}{2} + \frac{1}{x}$$



# Solutionbank

## Edexcel AS and A Level Modular Mathematics

### Exercise K, Question 3

#### Question:

Given that  $2y = x - \sin x \cos x$ , show that  $\frac{dy}{dx} = \sin^2 x$ .

[E]

#### Solution:

$$2y = x - \sin x \cos x$$

$$\therefore y = \frac{x}{2} - \frac{1}{2} \sin x \cos x$$

$$\frac{dy}{dx} = \frac{1}{2} - \left[ \frac{1}{2} \sin x ( - \sin x ) + \cos x \left( \frac{1}{2} \cos x \right) \right] \quad (\text{Product rule})$$

$$= \frac{1}{2} + \frac{1}{2} ( \sin^2 x ) - \frac{1}{2} \cos^2 x$$

$$= \frac{1}{2} ( 1 - \cos^2 x ) + \frac{1}{2} \sin^2 x$$

$$= \frac{1}{2} \sin^2 x + \frac{1}{2} \sin^2 x \quad (\text{Using } \cos^2 x + \sin^2 x \equiv 1)$$

$$= \sin^2 x$$

# Solutionbank

## Edexcel AS and A Level Modular Mathematics

### Exercise K, Question 4

#### Question:

Differentiate, with respect to  $x$ ,

(a)  $\frac{\sin x}{x}$ ,  $x > 0$

(b)  $\ln \frac{1}{x^2 + 9}$

[E]

#### Solution:

(a)  $y = \frac{\sin x}{x}$

$$\frac{dy}{dx} = \frac{x \cos x - \sin x \times 1}{x^2} \quad (\text{Using the quotient rule})$$

$$= \frac{x \cos x - \sin x}{x^2}$$

(b)  $y = \ln \frac{1}{x^2 + 9} = \ln 1 - \ln (x^2 + 9)$  (Using laws of logarithms)

$$\Rightarrow y = -\ln (x^2 + 9)$$

$$\therefore \frac{dy}{dx} = \frac{-2x}{x^2 + 9}$$

# Solutionbank

## Edexcel AS and A Level Modular Mathematics

Exercise K, Question 5

### Question:

Use the derivatives of  $\sin x$  and  $\cos x$  to prove that the derivative of  $\tan x$  is  $\sec^2 x$ .

[E]

### Solution:

$$\text{Let } y = \tan x = \frac{\sin x}{\cos x}$$

Use the quotient rule with  $u = \sin x$  and  $v = \cos x$ .

$$\text{Then } \frac{du}{dx} = \cos x \text{ and } \frac{dv}{dx} = -\sin x$$

As

$$\frac{dy}{dx} = \frac{v \frac{du}{dx} - u \frac{dv}{dx}}{v^2}$$

$$\frac{dy}{dx} = \frac{\cos x \cos x - \sin x (-\sin x)}{\cos^2 x}$$

$$= \frac{\cos^2 x + \sin^2 x}{\cos^2 x} \quad (\text{Use } \cos^2 x + \sin^2 x \equiv 1)$$

$$= \frac{1}{\cos^2 x}$$

$$= \sec^2 x \quad \left( \text{As } \sec x = \frac{1}{\cos x} \right)$$

So derivative of  $\tan x$  is  $\sec^2 x$ .

# Solutionbank

## Edexcel AS and A Level Modular Mathematics

Exercise K, Question 6

**Question:**

$$f(x) = \frac{x}{x^2 + 2}, x \in \mathbb{R}$$

Find the set of values of  $x$  for which  $f'(x) < 0$ .

[E]

**Solution:**

$$f(x) = \frac{x}{x^2 + 2}$$

$$f'(x) = \frac{(x^2 + 2)(1) - x(2x)}{(x^2 + 2)^2} = \frac{x^2 + 2 - 2x^2}{(x^2 + 2)^2} = \frac{2 - x^2}{(x^2 + 2)^2}$$

$$\text{When } f'(x) < 0, \frac{2 - x^2}{(x^2 + 2)^2} < 0$$

$$\therefore 2 - x^2 < 0 \quad [\text{As } (x^2 + 2)^2 > 0]$$

$$\therefore x^2 > 2$$

$$\therefore x < -\sqrt{2}, x > \sqrt{2}$$

© Pearson Education Ltd 2008

# Solutionbank

## Edexcel AS and A Level Modular Mathematics

Exercise K, Question 7

### Question:

The function  $f$  is defined for positive real values of  $x$  by

$$f(x) = 12 \ln x - x^{\frac{3}{2}}$$

Write down the set of values of  $x$  for which  $f(x)$  is an increasing function of  $x$

[E].

### Solution:

$$f(x) = 12 \ln x - x^{\frac{3}{2}}$$

$$f'(x) = 12 \times \frac{1}{x} - \frac{3}{2}x^{\frac{1}{2}}$$

When  $f(x)$  is an increasing function,  $f'(x) > 0$ .

$$\therefore \frac{12}{x} - \frac{3}{2}x^{\frac{1}{2}} > 0$$

$$\therefore \frac{12}{x} > \frac{3}{2}x^{\frac{1}{2}}$$

As  $x > 0$ , multiply both sides by  $x$  to give

$$12 > \frac{3}{2}x^{1\frac{1}{2}}$$

$$\therefore x^{\frac{3}{2}} < 8$$

$$\therefore x < 8^{\frac{2}{3}}$$

i.e.  $x < 4$

# Solutionbank

## Edexcel AS and A Level Modular Mathematics

Exercise K, Question 8

### Question:

Given that  $y = \cos 2x + \sin x$ ,  $0 < x < 2\pi$ , and  $x$  is in radians, find, to 2 decimal places, the values of  $x$  for which  $\frac{dy}{dx} = 0$ .

[E]

### Solution:

$$y = \cos 2x + \sin x$$

$$\frac{dy}{dx} = -2 \sin 2x + \cos x$$

$$\text{Put } \frac{dy}{dx} = 0$$

$$\therefore \cos x - 2 \sin 2x = 0$$

$$\therefore \cos x - 4 \sin x \cos x = 0 \quad (\text{Using double angle formula})$$

$$\text{i.e. } \cos x (1 - 4 \sin x) = 0.$$

$$\therefore \cos x = 0 \text{ or } \sin x = \frac{1}{4}$$

$$\therefore x = 1.57 \text{ or } 4.71 \text{ or } 0.25 \text{ or } 2.89$$

© Pearson Education Ltd 2008

# Solutionbank

## Edexcel AS and A Level Modular Mathematics

Exercise K, Question 9

### Question:

The maximum point on the curve with equation  $y = x\sqrt{\sin x}$ ,  $0 < x < \pi$ , is the point A. Show that the  $x$ -coordinate of point A satisfies the equation  $2 \tan x + x = 0$ .

[E]

### Solution:

$$y = x\sqrt{\sin x}$$

$$\frac{dy}{dx} = x \left[ \frac{1}{2} (\sin x)^{-\frac{1}{2}} \times \cos x \right] + (\sin x)^{\frac{1}{2}} \times 1$$

At the maximum point,  $\frac{dy}{dx} = 0$ .

$$\therefore \frac{x}{2} (\sin x)^{-\frac{1}{2}} \cos x + (\sin x)^{\frac{1}{2}} = 0$$

Multiply equation by  $2 (\sin x)^{\frac{1}{2}}$ :

$$x \cos x + 2 \sin x = 0$$

Divide equation by  $\cos x$ :

$$x + 2 \tan x = 0$$

# Solutionbank

## Edexcel AS and A Level Modular Mathematics

Exercise K, Question 10

### Question:

$$f(x) = e^{0.5x} - x^2, x \in \mathbb{R}$$

(a) Find  $f'(x)$ .

(b) By evaluating  $f'(6)$  and  $f'(7)$ , show that the curve with equation  $y = f(x)$  has a stationary point at  $x = p$ , where  $6 < p < 7$ .

[E]

### Solution:

$$\begin{aligned} \text{(a) } f(x) &= e^{0.5x} - x^2 \\ \therefore f'(x) &= 0.5e^{0.5x} - 2x \end{aligned}$$

$$\begin{aligned} \text{(b) } f'(6) &= -1.96 < 0 \\ f'(7) &= 2.56 > 0 \end{aligned}$$

As the sign changes and the function is continuous,  $f'(x) = 0$  has a root  $p$  where  $6 < p < 7$ .

So  $y = f(x)$  has a stationary point at  $x = p$ .

© Pearson Education Ltd 2008



# Solutionbank

## Edexcel AS and A Level Modular Mathematics

### Exercise K, Question 11

#### Question:

$$f(x) \equiv e^{2x} \sin 2x, 0 \leq x \leq \pi$$

(a) Use calculus to find the coordinates of the turning points on the graph of  $y = f(x)$ .

(b) Show that  $f''(x) = 8e^{2x} \cos 2x$ .

(c) Hence, or otherwise, determine which turning point is a maximum and which is a minimum.

[E]

#### Solution:

$$(a) f(x) = e^{2x} \sin 2x$$

$$\therefore f'(x) = e^{2x} (2 \cos 2x) + \sin 2x (2e^{2x})$$

$$\text{When } f'(x) = 0, 2e^{2x} (\cos 2x + \sin 2x) = 0$$

$$\therefore \sin 2x = -\cos 2x$$

Divide both sides by  $\cos 2x$ :

$$\tan 2x = -1$$

$$\therefore 2x = \frac{3\pi}{4} \text{ or } \frac{7\pi}{4}$$

$$\therefore x = \frac{3\pi}{8} \text{ or } \frac{7\pi}{8} \quad (\text{As } 0 \leq x \leq \pi)$$

$$\text{As } y = f(x), \text{ when } x = \frac{3\pi}{8}, y = \frac{1}{\sqrt{2}} e^{\frac{3\pi}{4}}$$

$$\text{and when } x = \frac{7\pi}{8}, y = -\frac{1}{\sqrt{2}} e^{\frac{7\pi}{4}}$$

So  $\left( \frac{3\pi}{8}, \frac{1}{\sqrt{2}} e^{\frac{3\pi}{4}} \right)$  and  $\left( \frac{7\pi}{8}, -\frac{1}{\sqrt{2}} e^{\frac{7\pi}{4}} \right)$  are stationary values.

$$(b) \text{ As } f'(x) = 2e^{2x} (\cos 2x + \sin 2x)$$

$$\begin{aligned} f''(x) &= 2e^{2x} (-2 \sin 2x + 2 \cos 2x) + 4e^{2x} (\cos 2x + \sin 2x) \\ &= 8e^{2x} \cos 2x \end{aligned}$$

$$(c) f'' \left( \frac{3\pi}{8} \right) = 8e^{\frac{3\pi}{4}} \cos \frac{3\pi}{4} = -4\sqrt{2}e^{\frac{3\pi}{4}} < 0$$

$$\therefore \text{maximum at } \left( \frac{3\pi}{8}, \frac{1}{\sqrt{2}}e^{\frac{3\pi}{4}} \right)$$

$$f'' \left( \frac{7\pi}{8} \right) = 8e^{\frac{7\pi}{4}} \cos \frac{7\pi}{4} = +4\sqrt{2}e^{\frac{7\pi}{4}} > 0$$

$$\therefore \text{minimum at } \left( \frac{7\pi}{8}, \frac{-1}{\sqrt{2}}e^{\frac{7\pi}{4}} \right).$$

# Solutionbank

## Edexcel AS and A Level Modular Mathematics

Exercise K, Question 12

### Question:

The curve **C** has equation  $y = 2e^x + 3x^2 + 2$ . The point **A** with coordinates (0, 4) lies on **C**. Find the equation of the tangent to **C** at **A**.

[E]

### Solution:

$$y = 2e^x + 3x^2 + 2$$

$$\frac{dy}{dx} = 2e^x + 6x$$

At the point **A** (0, 4),  $x = 0$ , so the gradient of the tangent at **A** is  $2e^0 + 6 \times 0 = 2$ .

$\therefore$  the equation of the tangent at **A** is

$$y - 4 = 2 ( x - 0 )$$

$$\text{i.e. } y = 2x + 4$$

© Pearson Education Ltd 2008

# Solutionbank

## Edexcel AS and A Level Modular Mathematics

Exercise K, Question 13

### Question:

The curve **C** has equation  $y = f(x)$ , where

$$f(x) = 3 \ln x + \frac{1}{x}, x > 0$$

The point **P** is a stationary point on **C**.

(a) Calculate the  $x$ -coordinate of **P**.

The point **Q** on **C** has  $x$ -coordinate 1.

(b) Find an equation for the normal to **C** at **Q**.

[E]

### Solution:

$$(a) f(x) = 3 \ln x + \frac{1}{x}$$

$$f'(x) = \frac{3}{x} - \frac{1}{x^2}$$

$$\text{When } f'(x) = 0, \frac{3}{x} - \frac{1}{x^2} = 0$$

Multiply equation by  $x^2$ :

$$3x - 1 = 0$$

$$3x = 1$$

$$x = \frac{1}{3}$$

So the  $x$ -coordinate of the stationary point **P** is  $\frac{1}{3}$ .

(b) At the point **Q**,  $x = 1$ .  $\therefore y = f(1) = 1$

The gradient of the curve at point **Q** is  $f'(1) = 3 - 1 = 2$ .

So the gradient of the normal to the curve at **Q** is  $-\frac{1}{2}$ .

$\therefore$  the equation of the normal is  $y - 1 = -\frac{1}{2}(x - 1)$

$$\text{i.e. } y = -\frac{1}{2}x + 1\frac{1}{2}$$

# Solutionbank

## Edexcel AS and A Level Modular Mathematics

Exercise K, Question 14

### Question:

Differentiate  $e^{2x} \cos x$  with respect to  $x$ .

The curve **C** has equation  $y = e^{2x} \cos x$ .

- (a) Show that the turning points on **C** occur when  $\tan x = 2$ .
- (b) Find an equation of the tangent to **C** at the point where  $x = 0$ .

[E]

### Solution:

Let  $f(x) = e^{2x} \cos x$

Then  $f'(x) = e^{2x}(-\sin x) + \cos x(2e^{2x})$

(a) The turning points occur when  $f'(x) = 0$ .

$$\therefore e^{2x}(2\cos x - \sin x) = 0$$

$$\therefore \sin x = 2\cos x$$

Divide both sides by  $\cos x$ :

$$\tan x = 2$$

(b) When  $x = 0$ ,  $y = f(0) = e^0 \cos 0 = 1$

The gradient of the curve at  $(0, 1)$  is  $f'(0)$ .

$$f'(0) = 0 + 2 = 2$$

This is the gradient of the tangent at  $(0, 1)$  also.

So the equation of the tangent at  $(0, 1)$  is

$$y - 1 = 2(x - 0)$$

$$\therefore y = 2x + 1$$

# Solutionbank

## Edexcel AS and A Level Modular Mathematics

Exercise K, Question 15

### Question:

Given that  $x = y^2 \ln y$ ,  $y > 0$ ,

(a) find  $\frac{dx}{dy}$

(b) use your answer to part (a) to find in terms of  $e$ , the value of  $\frac{dy}{dx}$  at  $y = e$ .

[E]

### Solution:

(a)  $x = y^2 \ln y$

Use the product rule to give

$$\frac{dx}{dy} = y^2 \left( \frac{1}{y} \right) + \ln y \times 2y = y + 2y \ln y$$

(b)  $\frac{dy}{dx} = \frac{1}{\frac{dx}{dy}} = \frac{1}{y + 2y \ln y}$

when  $y = e$ ,

$$\frac{dy}{dx} = \frac{1}{e + 2e \ln e} = \frac{1}{3e}$$

# Solutionbank

## Edexcel AS and A Level Modular Mathematics

Exercise K, Question 16

**Question:**

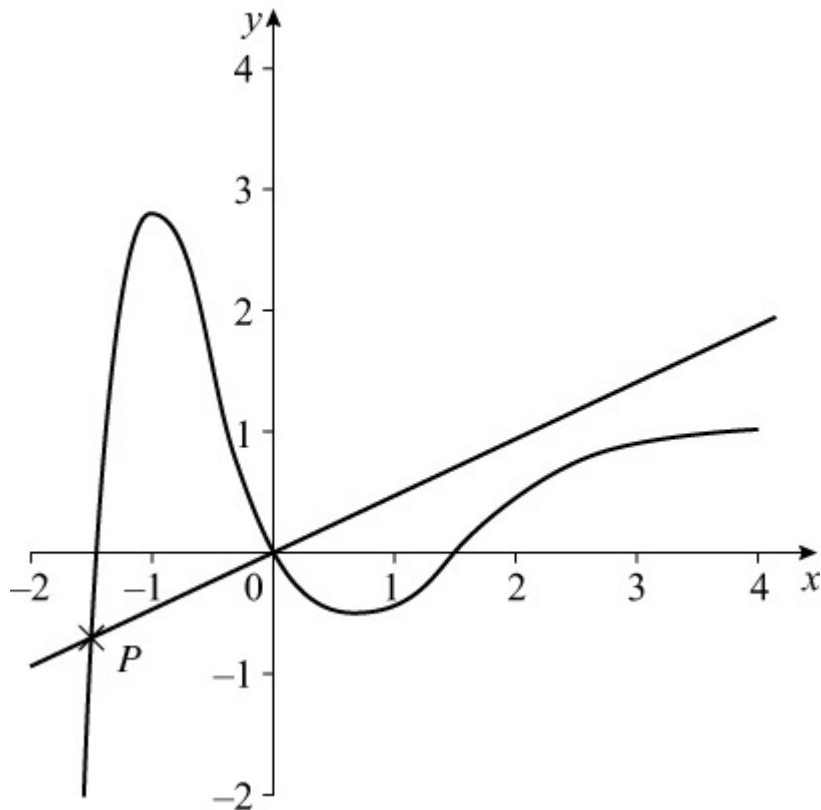

The figure shows part of the curve **C** with equation  $y = f(x)$ , where  $f(x) = (x^3 - 2x)e^{-x}$

(a) Find  $f'(x)$ .

The normal to **C** at the origin **O** intersects **C** at a point **P**, as shown in the figure.

(b) Show that the  $x$ -coordinate of **P** is the solution of the equation  $2x^2 = e^x + 4$ .

[E]

**Solution:**

$$\begin{aligned} \text{(a) } f(x) &= (x^3 - 2x)e^{-x} \\ \therefore f'(x) &= (x^3 - 2x)(-e^{-x}) + e^{-x}(3x^2 - 2) = e^{-x} \\ &(-x^3 + 3x^2 + 2x - 2) \end{aligned}$$

(b) The gradient of the curve at  $(0, 0)$  is  $f'(0) = -2$

The normal at the origin has gradient  $\frac{1}{2}$ .

So the equation of the normal at the origin is  $y = \frac{1}{2}x$

This normal meets the curve  $y = (x^3 - 2x)e^{-x}$  at the point  $P$ .

$\therefore$  the  $x$ -coordinate of  $P$  satisfies

$$\frac{1}{2}x = (x^3 - 2x)e^{-x}$$

Multiply both sides by  $2e^x$ :

$$xe^x = 2x^3 - 4x$$

Divide both sides by  $x$  and rearrange to give

$$2x^2 = e^x + 4$$



# Solutionbank

## Edexcel AS and A Level Modular Mathematics

Exercise K, Question 17

### Question:

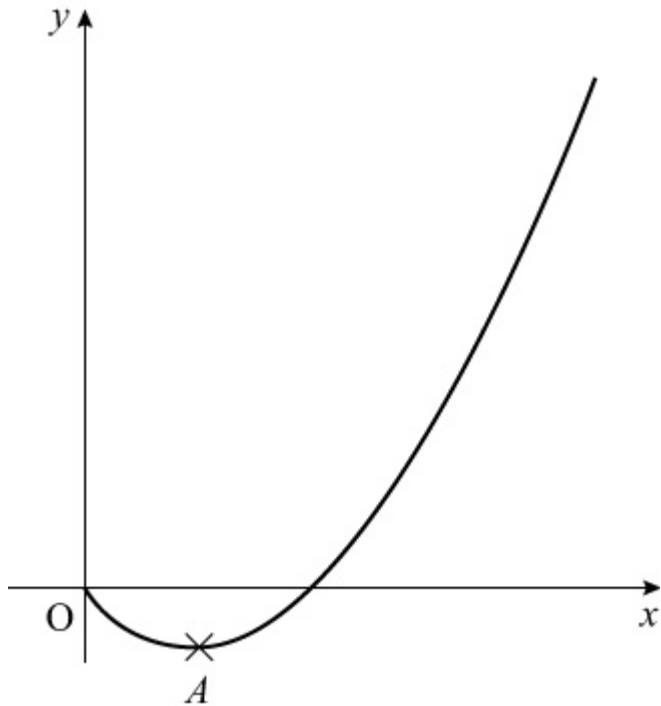

The diagram shows part of the curve with equation  $y = f(x)$  where  
 $f(x) = x(1+x)\ln x \quad \{x > 0\}$   
 The point A is the minimum point of the curve.

(a) Find  $f'(x)$ .

(b) Hence show that the  $x$ -coordinate of A is the solution of the equation  $x = g(x)$ , where

$$g(x) = e^{-\frac{1+x}{1+2x}}$$

[E]

### Solution:

$$(a) f(x) = x(1+x)\ln x = (x+x^2)\ln x$$

$$f'(x) = (x+x^2) \times \frac{1}{x} + \ln x(1+2x) = (1+x) + (1+2x)\ln x$$

(b) A is the minimum point on the curve  $y = f(x)$

$$\therefore f'(x) = 0 \text{ at point A.}$$

$$\therefore (1 + x) + (1 + 2x) \ln x = 0$$

$$\therefore (1 + 2x) \ln x = - (1 + x)$$

$$\therefore \ln x = - \frac{1 + x}{1 + 2x}$$

$$\therefore x = e^{- \frac{1 + x}{1 + 2x}}$$

i.e. the  $x$ -coordinate of  $A$  is a solution of  $x = g(x)$  where  $g(x) = e^{- \frac{1 + x}{1 + 2x}}$ .

# Solutionbank

## Edexcel AS and A Level Modular Mathematics

### Exercise A, Question 1

#### Question:

The curve **C**, with equation  $y = x^2 \ln x$ ,  $x > 0$ , has a stationary point P. Find, in terms of e, the coordinates of P. (7)

#### Solution:

$$y = x^2 \ln x, x > 0$$

Differentiate as a product:

$$\frac{dy}{dx} = x^2 \times \frac{1}{x} + 2x \ln x = x + 2x \ln x = x(1 + 2 \ln x)$$

$$\frac{dy}{dx} = 0 \Rightarrow 1 + 2 \ln x = 0 \text{ as } x > 0$$

$$\Rightarrow 2 \ln x = -1$$

$$\Rightarrow \ln x = -\frac{1}{2}$$

$$\Rightarrow x = e^{-\frac{1}{2}}$$

Substituting  $x = e^{-\frac{1}{2}}$ , in  $y = x^2 \ln x$

$$\Rightarrow y = \left(e^{-\frac{1}{2}}\right)^2 \ln e^{-\frac{1}{2}} = -\frac{1}{2}e^{-1}$$

So coordinates are  $\left(e^{-\frac{1}{2}}, -\frac{1}{2}e^{-1}\right)$

# Solutionbank

## Edexcel AS and A Level Modular Mathematics

### Exercise A, Question 2

#### Question:

$$f(x) = e^{2x-1}, x \geq 0$$

The curve **C** with equation  $y = f(x)$  meets the  $y$ -axis at **P**.

The tangent to **C** at **P** crosses the  $x$ -axis at **Q**.

(a) Find, to 3 decimal places, the area of triangle **POQ**, where **O** is the origin. (5)

The line  $y = 2$  intersects **C** at the point **R**.

(b) Find the exact value of the  $x$ -coordinate of **R**. (3)

#### Solution:

(a) **C** meets  $y$ -axis where  $x = 0$

$$\Rightarrow y = e^{-1}$$

Find gradient of curve at **P**.

$$\frac{dy}{dx} = 2e^{2x-1}$$

$$\text{At } x = 0, \frac{dy}{dx} = 2e^{-1}$$

Equation of tangent is  $y - e^{-1} = 2e^{-1}x$

This meets  $x$ -axis at **Q**, where  $y = 0$

$$\Rightarrow Q \equiv \left( -\frac{1}{2}, 0 \right)$$

$$\text{Area of } \triangle POQ = \frac{1}{2} \times \frac{1}{2} \times e^{-1} = \frac{1}{4}e^{-1} = 0.092$$

(b) At **R**,  $y = 2 \Rightarrow 2 = e^{2x-1}$

$$\Rightarrow 2x - 1 = \ln 2$$

$$\Rightarrow 2x = 1 + \ln 2$$

$$\Rightarrow x = \frac{1}{2} (1 + \ln 2)$$

# Solutionbank

## Edexcel AS and A Level Modular Mathematics

### Exercise A, Question 3

#### Question:

$$f(x) = \frac{3x}{x+1} - \frac{x+7}{x^2-1}, x > 1$$

(a) Show that  $f(x) = 3 - \frac{4}{x-1}, x > 1$ . (5)

(b) Find  $f^{-1}(x)$ . (4)

(c) Write down the domain of  $f^{-1}(x)$ . (1)

#### Solution:

(a)  $\frac{3x}{x+1} - \frac{x+7}{(x+1)(x-1)}, x > 1$

$$\equiv \frac{3x(x-1) - (x+7)}{(x+1)(x-1)}$$

$$\equiv \frac{3x^2 - 4x - 7}{(x+1)(x-1)}$$

$$\equiv \frac{(3x-7)(x+1)}{(x+1)(x-1)}$$

$$\equiv \frac{3x-7}{x-1}$$

$$\equiv \frac{3(x-1) - 4}{x-1}$$

$$\equiv 3 - \frac{4}{x-1}$$

(b) Let  $y = 3 - \frac{4}{x-1}$

$$\Rightarrow \frac{4}{x-1} = 3 - y$$

$$\Rightarrow \frac{x-1}{4} = \frac{1}{3-y}$$

$$\Rightarrow x-1 = \frac{4}{3-y}$$

$$\Rightarrow x = 1 + \frac{4}{3-y} \text{ or } \frac{7-y}{3-y}$$

$$\text{So } f^{-1}(x) = 1 + \frac{4}{3-x} \text{ or } \frac{7-x}{3-x}$$

(c) Domain of  $f^{-1}(x)$  is the range of  $f(x)$ .

$$x > 1 \Rightarrow \frac{4}{x-1} > 0 \Rightarrow f(x) = 3 - \frac{4}{x-1} < 3$$

So the domain of  $f^{-1}(x)$  is  $x < 3$

© Pearson Education Ltd 2008

# Solutionbank

## Edexcel AS and A Level Modular Mathematics

### Exercise A, Question 4

#### Question:

(a) Sketch, on the same set of axes, for  $x > 0$ , the graphs of  $y = -1 + \ln 3x$  and  $y = \frac{1}{x}$  (2)

The curves intersect at the point P whose  $x$ -coordinate is  $p$ . Show that

(b)  $p$  satisfies the equation  $p \ln 3p - p - 1 = 0$  (1)

(c)  $1 < p < 2$  (2)

The iterative formula

$$x_{n+1} = \frac{1}{3}e \left( 1 + \frac{1}{x_n} \right), x_0 = 2$$

is used to find an approximation for  $p$ .

(d) Write down the values of  $x_1, x_2, x_3$  and  $x_4$  giving your answers to 4 significant figures. (3)

(e) Prove that  $p = 1.66$  correct to 3 significant figures. (2)

#### Solution:

(a)

(b) At P,  $-1 + \ln 3p = \frac{1}{p}$

$$\Rightarrow -p + p \ln 3p = 1$$

$$\Rightarrow p \ln 3p - p - 1 = 0$$

(c) Let  $f(p) \equiv p \ln 3p - p - 1$

$$f(1) = \ln 3 - 2 = -0.901\dots$$

$$f(2) = 2 \ln 6 - 3 = +0.5835\dots$$

Sign change implies root between 1 and 2, so  $1 < p < 2$ .

(d)  $x_{n+1} = \frac{1}{3}e \left( 1 + \frac{1}{x_n} \right), x_0 = 2$

$$x_1 = \frac{1}{3}e^{\frac{3}{2}} = 1.494 \text{ (4 s.f.)}$$

$$x_2 = 1.770 \text{ (4 s.f.)}$$

$$x_3 = 1.594 \text{ (4 s.f.)}$$

$$x_4 = 1.697 \text{ (4 s.f.)}$$

$$\text{(e) } f(1.665) = +0.013$$

$$f(1.655) = -0.003$$

$\Rightarrow$  root between 1.655 and 1.665

$$\text{So } p = 1.66 \text{ (3 s.f.)}$$



# Solutionbank

## Edexcel AS and A Level Modular Mathematics

### Exercise A, Question 5

#### Question:

The curve  $C_1$  has equation

$$y = \cos 2x - 2 \sin^2 x$$

The curve  $C_2$  has equation

$$y = \sin 2x$$

(a) Show that the  $x$ -coordinates of the points of intersection of  $C_1$  and  $C_2$  satisfy the equation

$$2 \cos 2x - \sin 2x = 1 \quad (3)$$

(b) Express  $2 \cos 2x - \sin 2x$  in the form  $R \cos (2x + \alpha)$ , where  $R > 0$  and  $0 < \alpha < \frac{\pi}{2}$ , giving the exact value of  $R$  and giving  $\alpha$  in radians to 3 decimal places. (4)

(c) Find the  $x$ -coordinates of the points of intersection of  $C_1$  and  $C_2$  in the interval  $0 \leq x < \pi$ , giving your answers in radians to 2 decimal places. (5)

#### Solution:

(a) Where  $C_1$  and  $C_2$  meet

$$\cos 2x - 2 \sin^2 x = \sin 2x$$

$$\text{Using } \cos 2x \equiv 1 - 2 \sin^2 x \quad \Rightarrow \quad -2 \sin^2 x \equiv \cos 2x - 1$$

$$\text{So } \cos 2x + (\cos 2x - 1) = \sin 2x$$

$$\Rightarrow 2 \cos 2x - \sin 2x = 1$$

(b) Let  $2 \cos 2x - \sin 2x \equiv R \cos (2x + \alpha)$

$$\equiv R \cos 2x \cos \alpha - R \sin 2x \sin \alpha$$

$$\text{Compare: } R \cos \alpha = 2, R \sin \alpha = 1$$

$$\text{Divide: } \tan \alpha = \frac{1}{2} \quad \Rightarrow \quad \alpha = 0.464 \text{ (3 d.p.)}$$

$$\text{Square and add: } R^2 (\cos^2 \alpha + \sin^2 \alpha) = 2^2 + 1^2 = 5$$

$$\Rightarrow R = \sqrt{5}$$

$$\text{So } 2 \cos 2x - \sin 2x \equiv \sqrt{5} \cos (2x + 0.464)$$

(c)  $2 \cos 2x - \sin 2x = 1$

$$\Rightarrow \sqrt{5} \cos ( 2x + 0.464 ) = 1$$

$$\Rightarrow \cos \left( 2x + 0.464 \right) = \frac{1}{\sqrt{5}}$$

$$\Rightarrow 2x + 0.464 = 1.107, 5.176 \quad 0.464 \leq 2x + 0.464 < 6.747$$

$$\Rightarrow 2x = 0.643, 4.712$$

$$\Rightarrow x = 0.32, 2.36 \text{ (2 d.p.)}$$

# Solutionbank

## Edexcel AS and A Level Modular Mathematics

### Exercise A, Question 6

#### Question:

(a) Given that  $y = \ln \sec x$ ,  $-\frac{\pi}{2} < x \leq 0$ , use the substitution  $u = \sec x$ , or otherwise, to show that  $\frac{dy}{dx} = \tan x$ . (3)

The curve **C** has equation  $y = \tan x + \ln \sec x$ ,  $-\frac{\pi}{2} < x \leq 0$ .

At the point **P** on **C**, whose  $x$ -coordinate is  $p$ , the gradient is 3.

(b) Show that  $\tan p = -2$ . (6)

(c) Find the exact value of  $\sec p$ , showing your working clearly. (2)

(d) Find the  $y$ -coordinate of **P**, in the form  $a + k \ln b$ , where  $a$ ,  $k$  and  $b$  are rational numbers. (2)

#### Solution:

(a)  $y = \ln \sec x$

Let  $u = \sec x \Rightarrow \frac{du}{dx} = \sec x \tan x$

so  $y = \ln u \Rightarrow \frac{dy}{du} = \frac{1}{u}$

Using  $\frac{dy}{dx} = \frac{dy}{du} \times \frac{du}{dx}$

$\frac{dy}{dx} = \frac{1}{u} \times \sec x \tan x = \frac{1}{\sec x} \sec x \tan x = \tan x$

(b)  $\frac{dy}{dx} = \sec^2 x + \tan x$

So  $\sec^2 p + \tan p = 3$

$$\Rightarrow 1 + \tan^2 p + \tan p = 3$$

$$\Rightarrow \tan^2 p + \tan p - 2 = 0$$

$$\Rightarrow (\tan p - 1)(\tan p + 2) = 0$$

As  $-\frac{\pi}{2} < x \leq 0$  (4th quadrant),  $\tan p$  is negative

So  $\tan p = -2$

$$(c) \sec^2 p = 1 + \tan^2 p = 5 \Rightarrow \sec p = + \sqrt{5} \quad (4\text{th quadrant})$$

$$(d) y = \ln \sqrt{5} + (-2) = -2 + \frac{1}{2} \ln 5$$

© Pearson Education Ltd 2008

# Solutionbank

## Edexcel AS and A Level Modular Mathematics

### Exercise A, Question 7

#### Question:

The diagram shows a sketch of part of the curve with equation  $y = f(x)$ . The curve has no further turning points.

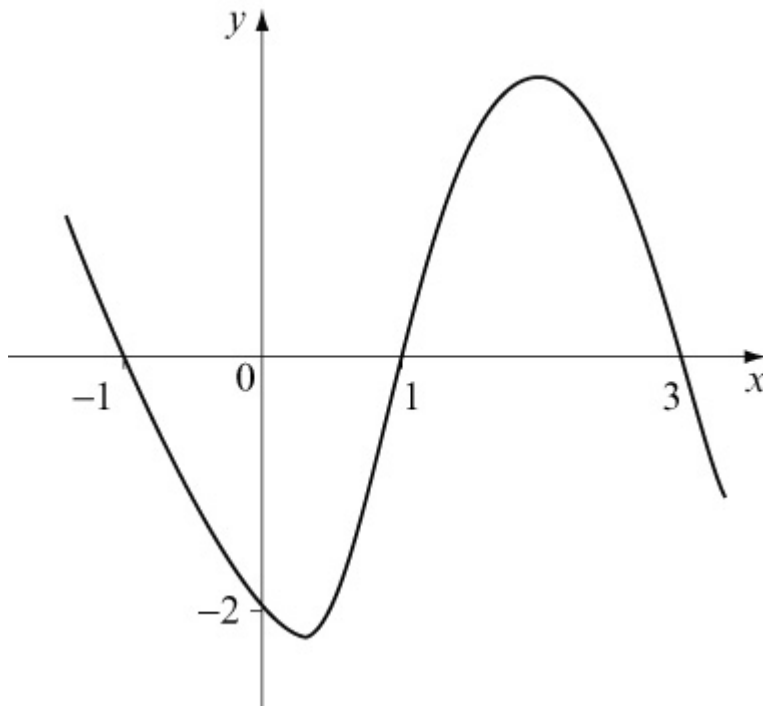

On separate diagrams show a sketch of the curve with equation

(a)  $y = 2f(-x)$  (3)

(b)  $y = |f(2x)|$  (3)

In each case show the coordinates of points in which the curve meets the coordinate axes.

The function  $g$  is given by

$$g : x \rightarrow |x + 1| - k, x \in \mathbb{R}, k > 1$$

(c) Sketch the graph of  $g$ , showing, in terms of  $k$ , the  $y$ -coordinate of the point of intersection of the graph with the  $y$ -axis. (3)

Find, in terms of  $k$ ,

(d) the range of  $g(x)$  (1)

(e)  $gf(0)$  (2)

(f) the solution of  $g(x) = x(3)$

**Solution:**

(a)

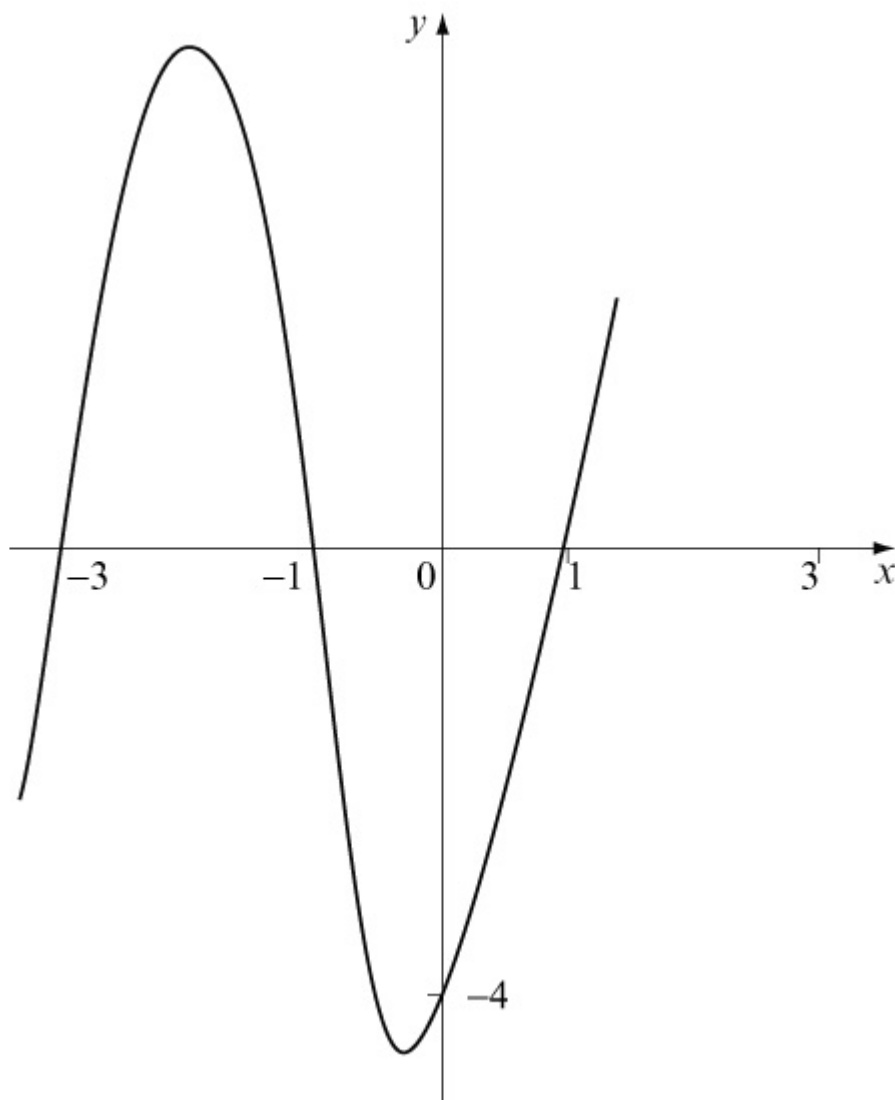

(b)

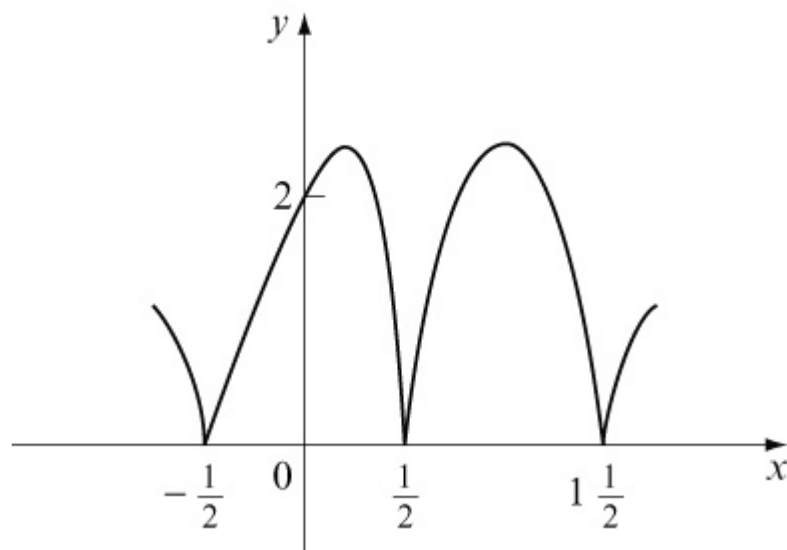

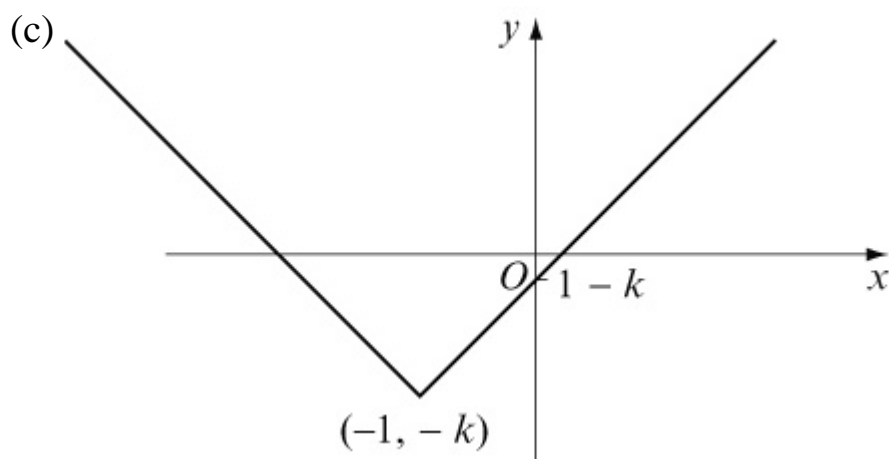

(d)  $g(x) \geq -k$

(e)  $gf(0) = g(-2) = |-1| - k = 1 - k$

(f)  $y = x$  meets  $y = |x + 1| - k$

where  $x = -(x + 1) - k$

$$\Rightarrow 2x = -(1 + k)$$

$$\Rightarrow x = -\frac{1+k}{2}$$

# Solutionbank C3

## Edexcel AS and A Level Modular Mathematics

### Review Exercise

#### Exercise A, Question 1

#### Question:

Simplify

i  $\frac{2x^2 - 7x - 15}{x^2 - 25}$

ii  $\frac{x^3 + 1}{x + 1}$ .

#### Solution:

a

$$\frac{2x^2 - 7x - 15}{x^2 - 25} = \frac{(2x + 3)(x - 5)}{(x + 5)(x - 5)}$$

← Take care with signs.

$$= \frac{2x + 3}{x + 5}$$

← Difference of two squares.

b

$$x^3 + 1 = (x + 1)(x^2 - x + 1)$$

$$\Rightarrow \frac{x^3 + 1}{x + 1} = x^2 - x + 1$$

← Use the factor theorem to find the factor  $x + 1$ .



# Solutionbank C3

## Edexcel AS and A Level Modular Mathematics

Review Exercise  
Exercise A, Question 2

### Question:

Express  $\frac{4x}{x^2 - 2x - 3} + \frac{1}{x^2 + x}$  as a single fraction, giving your answer in its simplest form.

### Solution:

$$\begin{aligned}
 x^2 - 2x - 3 &= (x-3)(x+1) && \leftarrow \text{Factorise both} \\
 x^2 + x &= x(x+1) && \text{denominators.} \\
 \Rightarrow \frac{4x}{x^2 - 2x - 3} + \frac{1}{x^2 + x} &= \frac{4x}{(x-3)(x+1)} + \frac{1}{x(x+1)} && \leftarrow \text{The L.C.M. of the} \\
 &= \frac{4x^2 + (x-3)}{x(x+1)(x-3)} && \text{denominators is} \\
 &= \frac{(4x-3)(x+1)}{x(x+1)(x-3)} && \leftarrow \text{Factorise quadratic} \\
 &= \frac{4x-3}{x(x-3)} && \text{numerator.}
 \end{aligned}$$

# Solutionbank C3

## Edexcel AS and A Level Modular Mathematics

### Review Exercise

#### Exercise A, Question 3

#### Question:

Express  $\frac{2x^2 + 3x}{(2x+3)(x-2)} - \frac{6}{x^2 - x - 2}$  as a single fraction in its simplest form. *E*

#### Solution:

$$\begin{aligned}
 & \frac{2x^2 + 3x}{(2x+3)(x-2)} - \frac{6}{x^2 - x - 2} \\
 = & \frac{x \cancel{(2x+3)}}{\cancel{(2x+3)}(x-2)} - \frac{6}{(x-2)(x+1)} \quad \leftarrow \text{Factorise all the quadratic expressions.} \\
 = & \frac{x}{x-2} - \frac{6}{(x-2)(x+1)} \\
 = & \frac{x(x+1) - 6}{(x-2)(x+1)} \\
 = & \frac{x^2 + x - 6}{(x-2)(x+1)} \quad \leftarrow \text{Check the quadratic numerator to see if it factorises.} \\
 = & \frac{(x+3)\cancel{(x-2)}}{\cancel{(x-2)}(x+1)} \\
 = & \frac{x+3}{x+1}
 \end{aligned}$$

# Solutionbank C3

## Edexcel AS and A Level Modular Mathematics

### Review Exercise

#### Exercise A, Question 4

#### Question:

- a Given that  
 $16x^3 - 36x^2 - 12x + 5 \equiv (2x+1)(8x^2 + ax + b)$ ,  
 find the value of  $a$  and the value of  $b$ .
- b Hence, or otherwise, simplify

$$\frac{16x^3 - 36x^2 - 12x + 5}{4x - 1}$$

#### Solution:

a

$$\begin{array}{rcl}
 16x^3 - 36x^2 - 12x + 5 & \equiv & (2x+1)(8x^2 + ax + b) \\
 b & = & 5 \\
 \text{and } -36 & = & 8 + 2a \\
 \Rightarrow 2a & = & -44 \\
 a & = & -22
 \end{array}$$

So

$$\begin{array}{rcl}
 16x^3 - 36x^2 - 12x + 5 & \equiv & (2x+1)(8x^2 - 22x + 5) \\
 & = & (2x+1)(2x-5)(4x-1)
 \end{array}$$

Annotations:

- Compare the constant term on both sides.
- Compare the coefficient of  $x^2$  on both sides.
- You can check your values by comparing the coefficient of  $x$  on both sides.

- b Using the result in a

$$\frac{16x^3 - 36x^2 - 12x + 5}{4x - 1} = (2x+1)(2x-5)$$

# Solutionbank C3

## Edexcel AS and A Level Modular Mathematics

### Review Exercise

#### Exercise A, Question 5

#### Question:

$$f(x) = 1 - \frac{3}{x+2} + \frac{3}{(x+2)^2}, x \neq -2$$

a Show that  $f(x) = \frac{x^2 + x + 1}{(x+2)^2}, x \neq -2$

b Show that  $x^2 + x + 1 > 0$  for all values of  $x$ .

c Show that  $f(x) > 0$  for all values of  $x, x \neq -2$ .

*E*

#### Solution:

a

$$\begin{aligned} & 1 - \frac{3}{x+2} + \frac{3}{(x+2)^2} \\ = & \frac{(x+2)^2 - 3(x+2) + 3}{(x+2)^2} \\ = & \frac{x^2 + 4x + 4 - 3x - 6 + 3}{(x+2)^2} \\ = & \frac{x^2 + x + 1}{(x+2)^2} \end{aligned}$$

b

$$\begin{aligned} x^2 + x + 1 &= \left(x + \frac{1}{2}\right)^2 + \frac{3}{4} \\ &\geq \frac{3}{4} \\ &> 0 \text{ for all values of } x \end{aligned}$$

Use the method of completing the square.

As  $\left(x + \frac{1}{2}\right)^2 \geq 0$ .

c  $\frac{x^2 + x + 1}{(x+2)^2} > 0$

as  $x^2 + x + 1 > 0$  from b

and  $(x+2)^2 > 0$  as  $x \neq -2$

# Solutionbank C3

## Edexcel AS and A Level Modular Mathematics

Review Exercise  
Exercise A, Question 6

### Question:

a Show that

$$\frac{4}{(x+1)^2} - \frac{1}{(x+1)} - \frac{1}{2} = \frac{5-4x-x^2}{2(x+1)^2}.$$

b Hence solve

$$\frac{4}{(x+1)^2} < \frac{1}{(x+1)} + \frac{1}{2}, x \neq -1$$

### Solution:

**a**

$$\begin{aligned} & \frac{4}{(x+1)^2} - \frac{1}{x+1} - \frac{1}{2} \\ = & \frac{4(2) - 2(x+1) - (x+1)^2}{2(x+1)^2} \\ = & \frac{8 - 2x - 2 - x^2 - 2x - 1}{2(x+1)^2} \\ = & \frac{5 - 4x - x^2}{2(x+1)^2} \end{aligned}$$

← Be careful with signs.

**b**

$$\begin{aligned} & = \frac{4}{(x+1)^2} < \frac{1}{x+1} + \frac{1}{2} \\ \Rightarrow & \frac{4}{(x+1)^2} - \frac{1}{x+1} - \frac{1}{2} < 0 \\ \Rightarrow & \frac{5 - 4x - x^2}{2(x+1)^2} < 0 \\ \Rightarrow & 5 - 4x - x^2 < 0 \\ \Rightarrow & x^2 + 4x - 5 > 0 \\ \Rightarrow & (x+5)(x-1) > 0 \\ \Rightarrow & x < -5, x > 1 \end{aligned}$$

← You can see the relationship with a.

← If  $x \neq -1, (x+1)^2 > 0$ .

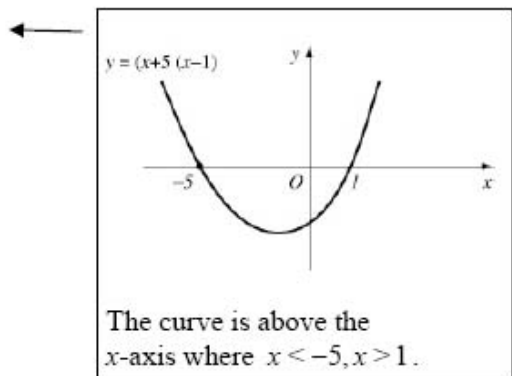

# Solutionbank C3

## Edexcel AS and A Level Modular Mathematics

### Review Exercise

#### Exercise A, Question 7

#### Question:

$$f(x) = \frac{x}{x+3} - \frac{x+24}{2x^2+5x-3}, \left\{ x \in \mathbb{R}, x > \frac{1}{2} \right\}.$$

a Show that  $f(x) = \frac{2(x-4)}{2x-1} \left\{ x \in \mathbb{R}, x > \frac{1}{2} \right\}$ .

b Find  $f^{-1}(x)$ .

#### Solution:

a

$$\begin{aligned} f(x) &= \frac{x}{x+3} - \frac{x+24}{(2x-1)(x+3)} \\ &= \frac{x(2x-1) - (x+24)}{(2x-1)(x+3)} \\ &= \frac{2x^2 - 2x - 24}{(2x-1)(x+3)} \\ &= \frac{2(x^2 - x - 12)}{(2x-1)(x+3)} \\ &= \frac{2(x-4)\cancel{(x+3)}}{(2x-1)\cancel{(x+3)}} \\ &= \frac{2(x-4)}{2x-1} \end{aligned}$$

Be careful: always insert brackets. It is very common to see  $-x+24$ .

b

$$\begin{aligned} \text{Let } y &= \frac{2x-8}{2x-1} \\ \Rightarrow 2xy - y &= 2x-8 \\ 2xy - 2x &= y-8 \\ 2x(y-1) &= y-8 \\ x &= \frac{y-8}{2(y-1)} \\ f^{-1}(x) &= \frac{x-8}{2(x-1)} \end{aligned}$$

$f^{-1}(x)$  is a function of  $x$ ; you must express it in terms of  $x$ .

# Solutionbank C3

## Edexcel AS and A Level Modular Mathematics

Review Exercise  
Exercise A, Question 8

### Question:

The graph of the increasing function  $f$  passes through the points  $A(0, -2)$ ,  $B(3, 0)$  and  $C(5, 2)$ , as shown.

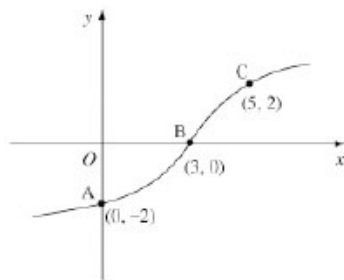

- a Sketch the graph of  $f^{-1}$ , showing the images of A, B and C.  
The function  $g$  is defined by  
 $g: x \rightarrow \sqrt{x^2 + 2}, x \in \mathbb{R}$
- b Find i  $fg(\sqrt{23})$ , ii  $gf(0)$ .

### Solution:

a

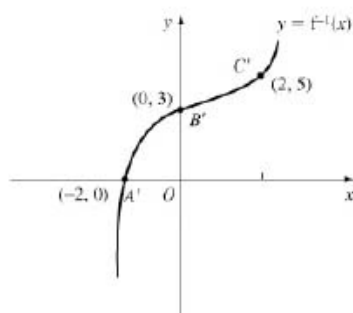

$y = f^{-1}(x)$  is the reflection of  $y = f(x)$  in the line  $y = x$ .  
Points with coordinates

b i

$$\begin{aligned} fg(\sqrt{23}) &= f(\sqrt{23+2}) \\ &= f(5) \\ &= 2 \end{aligned}$$

As  $f(5) = 2$ , indicated by the point C on graph of  $f$ .

ii

$$\begin{aligned} gf(0) &= g(-2) \\ &= \sqrt{(-2)^2 + 2} \\ &= \sqrt{6} \end{aligned}$$

The point  $(0, -2)$  on the graph of  $y = f(x)$  implies that  $f(0) = -2$ .



# Solutionbank C3

## Edexcel AS and A Level Modular Mathematics

Review Exercise  
Exercise A, Question 9

### Question:

The functions  $f$  and  $g$  are defined by

$$f : x \rightarrow 3x + 4, \quad x \in \mathbb{R}, x > 0,$$

$$g : x \rightarrow \frac{x}{x-2}, \quad x \in \mathbb{R}, x > 2.$$

- Find the inverse function  $f^{-1}(x)$ , stating its domain.
- Find the exact value of  $gf\left(\frac{1}{2}\right)$ .
- State the range of  $g$ .
- Find  $g^{-1}(x)$ , stating its domain.

### Solution:

a Let

$$y = 3x + 4$$

$$\Rightarrow 3x = y - 4$$

$$x = \frac{y - 4}{3}$$

$$f^{-1}(x) = \frac{x - 4}{3}$$

Remember to write in terms of  $x$ .

domain of  $f^{-1}(x)$  is  $x > 4$

The domain of  $f^{-1}(x)$  is the range of  $f(x)$ .  
As  $x > 0, 3x + 4 > 4$ .

b

$$gf\left(\frac{1}{2}\right) = g\left(5\frac{1}{2}\right)$$

$$= \frac{5\frac{1}{2}}{5\frac{1}{2} - 2}$$

$$= \frac{5\frac{1}{2}}{3\frac{1}{2}}$$

$$= \frac{11}{2} \times \frac{2}{7} = \frac{11}{7}$$

$$f\left(\frac{1}{2}\right) = 3\left(\frac{1}{2}\right) + 4$$

You must not give a decimal answer.

c

$$g(x) = \frac{x}{x-2} = \frac{x-2+2}{x-2} = 1 + \frac{2}{x-2}$$

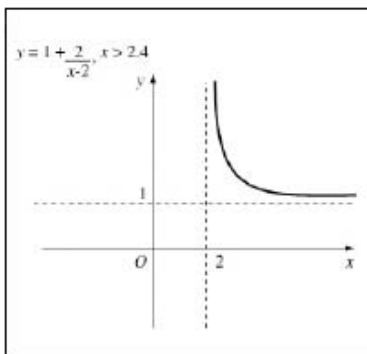

range  $g(x) > 1$

d

$$y = \frac{x}{x-2}$$

$$\Rightarrow yx - 2y = x$$

$$\Rightarrow x(y-1) = 2y$$

$$\Rightarrow x = \frac{2y}{y-1}$$

$$g^{-1}(x) = \frac{2x}{x-1}, \text{ domain } x > 1$$

The domain of  $g^{-1}(x)$  is the range of  $g(x)$  found in c.

# Solutionbank C3

## Edexcel AS and A Level Modular Mathematics

Review Exercise  
Exercise A, Question 10

### Question:

The function  $f$  is defined by

$$f : x \rightarrow \frac{5x+1}{x^2+x-2} - \frac{3}{x+2}, x > 1.$$

a Show that  $f(x) = \frac{2}{x-1}, x > 1.$

b Find  $f^{-1}(x).$

The function  $g$  is defined by

$$g : x \rightarrow x^2 + 5, \quad x \in \mathbb{R}$$

c Solve  $fg(x) = \frac{1}{4}.$

*E*

### Solution:

**a**

$$\begin{aligned} & \frac{5x+1}{(x+2)(x-1)} - \frac{3}{x+2} && \leftarrow \text{Factorise the quadratic expression.} \\ = & \frac{5x+1-3(x-1)}{(x+2)(x-1)} \\ = & \frac{2x+4}{(x+2)(x-1)} \\ = & \frac{2(x+2)}{(x+2)(x-1)} && \leftarrow x \neq -2 \text{ as } x > 1 \end{aligned}$$

so  $f(x) = \frac{2}{x-1} \quad x > 1$

**b** Let  $y = \frac{2}{x-1}$

$$\begin{aligned} \Rightarrow yx - y &= 2 \\ yx &= 2 + y \\ x &= \frac{2+y}{y} \end{aligned}$$

$$f^{-1}(x) = \frac{2+x}{x} \left[ \text{or } 1 + \frac{2}{x} \right] \quad \leftarrow \text{The domain is } x > 0.$$

**c**

$$\begin{aligned} fg(x) &= f(x^2+5) \\ &= \frac{2}{x^2+4} \\ \frac{2}{x^2+4} &= \frac{1}{4} \Rightarrow x^2 = 4 \\ \Rightarrow x &= \pm 2 \end{aligned}$$

Both answers are valid, as  $g$  is defined for  $x \in \mathbb{R}$ .

# Solutionbank C3

## Edexcel AS and A Level Modular Mathematics

Review Exercise  
Exercise A, Question 11

### Question:

The functions  $f$  and  $g$  are defined by

$$f: x \rightarrow (x-4)^2 - 16, \quad x \in \mathbb{R}, x > 0,$$

$$g: x \rightarrow \frac{8}{1-x}, \quad x \in \mathbb{R}, x < 1.$$

- Find the range of  $f$ .
- Explain why, with the given domain for  $f$ ,  $f^{-1}(x)$  does not exist.
- Show that  $fg(x) = \frac{64x}{(1-x)^2}$ .
- Find  $g^{-1}(x)$ , stating its domain.

### Solution:

a  $f(x) \geq -16$

b For  $f(x)$  to have an inverse function it must be one-to-one. With the given domain  $f$ , is many-to-one e.g.  $f(2) = -12$  and  $f(6) = -12$ .

Either draw a graph of  $y = f(x)$  or realise that  $(x-4)^2 \geq 0$  so  $(x-4)^2 - 16 \geq -16$ .

c

$$\begin{aligned} fg(x) &= f\left(\frac{8}{1-x}\right) \\ &= \left(\frac{8}{1-x} - 4\right)^2 - 16 \\ &= \left(\frac{64}{(1-x)^2} - \frac{64}{1-x} + 6\right) - 16 \\ &= \frac{64}{(1-x)^2} - \frac{64}{1-x} \\ &= \frac{64[1-(1-x)]}{(1-x)^2} \\ &= \frac{64x}{(1-x)^2} \end{aligned}$$

d Let  $y = \frac{8}{1-x}$

$$\begin{aligned} \Rightarrow y - yx &= 8 \\ \Rightarrow xy &= y - 8 \\ x &= \frac{y-8}{y} \\ \Rightarrow g^{-1}(x) &= \frac{x-8}{x} \end{aligned}$$

domain is  $x > 0$

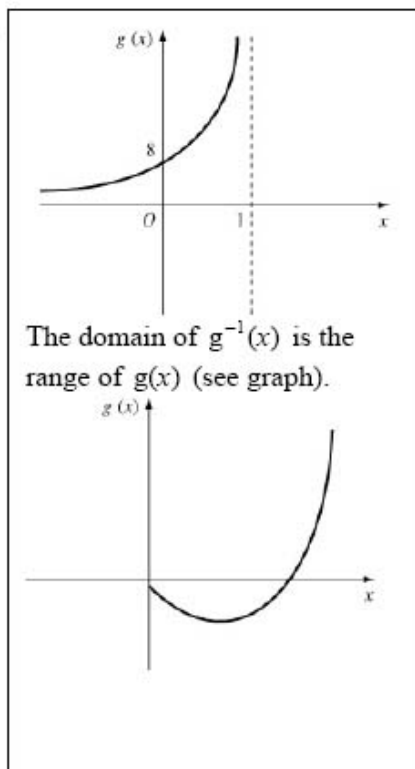

# Solutionbank C3

## Edexcel AS and A Level Modular Mathematics

Review Exercise  
Exercise A, Question 12

### Question:

The function  $f(x)$  is defined by

$$f(x) = \begin{cases} -2(x+1) & -2 \leq x \leq -1 \\ (x+1)(2-x) & -1 < x \leq 2 \end{cases}$$

- Sketch the graph of  $f(x)$ .
- Write down the range of  $f$ .
- Find the values of  $x$  for which  $f(x) < 2$ .

### Solution:

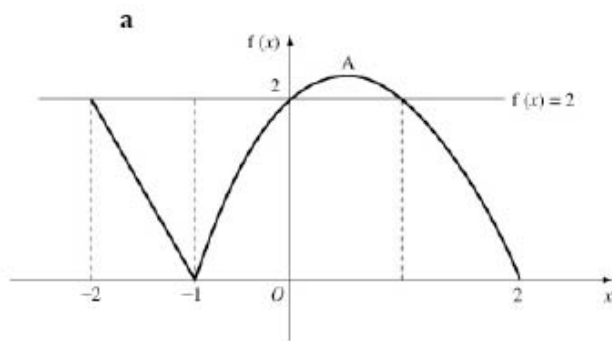

$-2(x+1)$  in  $[-2, -1]$  is a straight line between  $(-2, 2)$  and  $(-1, 0)$ .  
 $(x+1)(2-x)$  is a  $\cap$ -shaped parabola in  $[-1, 2]$ .

- The vertex  $A$  of the parabola has  $x$ -coordinate  $\frac{1}{2}$  (symmetry) so  
 $A = (\frac{1}{2}, 2\frac{1}{4})$ .

The greatest value of  $f(x)$  is the  $f(x)$  coordinate of the vertex of the parabola.

The range of  $f(x)$  is  $0 \leq f(x) \leq 2\frac{1}{4}$ .

- The parabola crosses the line  $f(x) = 2$  where  $x = 0$  and  $x = 1$  (symmetry).  
The line meets  $f(x) = 2$  at  $(-2, 2)$ , so  $f(x) < 2$  where  $-2 < x < 0, 1 < x \leq 2$

Use the graph.

# Solutionbank C3

## Edexcel AS and A Level Modular Mathematics

Review Exercise  
Exercise A, Question 13

### Question:

- a Express  $4x^2 - 4x - 3$  in the form  $(ax - b)^2 - c$ , where  $a$ ,  $b$  and  $c$  are positive constants to be found.

The function  $f$  is defined by

$$f : x \rightarrow 4x^2 - 4x - 3, \quad \left\{ x \in \mathbb{R}, x \geq \frac{1}{2} \right\}.$$

- b Sketch the graph of  $f$ .  
c Sketch the graph of  $f^{-1}$ .  
d Find  $f^{-1}(x)$ , stating its domain.

### Solution:



**a**

$$\begin{aligned}
 4x^2 - 4x - 3 &\equiv (ax - b)^2 - c \\
 &\equiv a^2x^2 - 2abx + b^2 - c \\
 \Rightarrow a &= 2 \\
 \Rightarrow 2ab &= 4 \Rightarrow b = 1 \\
 \Rightarrow b^2 - c &= -3 \\
 \Rightarrow 1 - c &= -3 \\
 \Rightarrow c &= 4 \\
 \Rightarrow 4x^2 - 4x - 3 &\equiv (2x - 1)^2 - 4
 \end{aligned}$$

Compare coefficients of  $x^2$ .

Compare coefficients of  $x$ .

Compare coefficients of constant term.

**b**

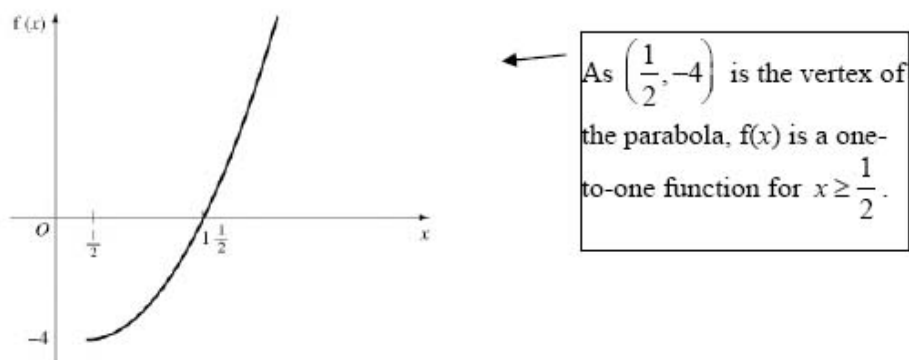

**c**

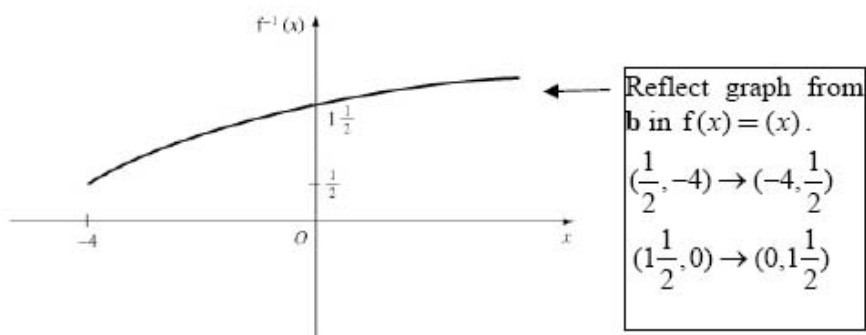

**d**

Let

$$\begin{aligned}
 y &= (2x - 1)^2 - 4 \\
 \Rightarrow (2x - 1)^2 &= y + 4 \\
 2x - 1 &= \sqrt{y + 4} \\
 x &= \frac{1}{2}(1 + \sqrt{y + 4}) \\
 \Rightarrow f^{-1}(x) &= \frac{1}{2}(1 + \sqrt{x + 4}), x \geq -4
 \end{aligned}$$

$-\sqrt{y + 4}$  not appropriate.

The graph in **c** gives the domain.

# Solutionbank C3

## Edexcel AS and A Level Modular Mathematics

Review Exercise  
Exercise A, Question 14

### Question:

The functions  $f$  and  $g$  are defined by

$$f : x \rightarrow \frac{x+2}{x}, x \in \mathbb{R}, x \neq 0.$$

$$g : x \rightarrow \ln(2x-5), x \in \mathbb{R}, x > 2\frac{1}{2}.$$

- Sketch the graph of  $f$ .
- Show that  $f^2(x) = \frac{3x+2}{x+2}$ .  
[ $f^2(x)$  means  $ff(x)$ ]
- Find the exact value of  $gf\left(\frac{1}{4}\right)$ .
- Find  $g^{-1}(x)$ , stating its domain.

### Solution:

$$\text{a } \frac{x+2}{x} = 1 + \frac{2}{x}$$

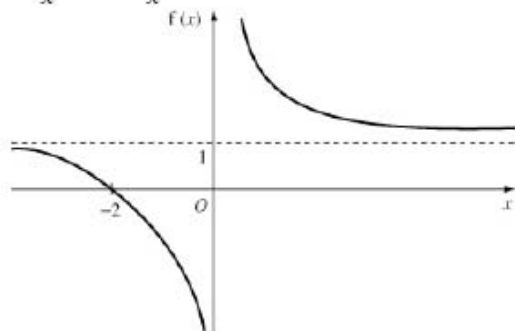

**b**

$$f^2(x) = f\left(\frac{x+2}{x}\right)$$

$$= \frac{\frac{x+2}{x} + 2}{\frac{x+2}{x}}$$

$$= \frac{(3x+2)}{x} \times \frac{x}{(x+2)}$$

$$= \frac{3x+2}{x+2}$$

$$\left[ \frac{x+2+2x}{\frac{x+2}{x}} \right]$$

**c**

$$gf\left(\frac{1}{4}\right) = g\left(\frac{2\frac{1}{4}}{\frac{1}{4}}\right) = g(9)$$

$$= \ln(18-5)$$

$$= \ln 13$$

**d** Let  $y = \ln(2x-5)$

$$e^y = 2x-5$$

$$\Rightarrow x = \frac{e^y + 5}{2}$$

$$g^{-1}(x) = \frac{e^x + 5}{2} \quad x \in \mathbb{R}$$

← The range of  $g(x)$  is  $x \in \mathbb{R}$  so the domain of  $g^{-1}(x)$  is  $x \in \mathbb{R}$ .

# Solutionbank C3

## Edexcel AS and A Level Modular Mathematics

### Review Exercise Exercise A, Question 15

#### Question:

Solve the following equations, giving your answers to 3 significant figures.

- a  $3e^{(2x+5)} = 4$   
 b  $3^x = 5^{1-x}$   
 c  $2\ln(2x-1) = 1 + \ln 7$

#### Solution:

a

$$3e^{(2x+5)} = 4$$

$$\Rightarrow e^{(2x+5)} = \frac{4}{3}$$

← Divide by 3 before taking logs.

$$\Rightarrow 2x+5 = \ln \frac{4}{3}$$

← If  $e^a = b \Rightarrow a = \ln b$

$$x = \frac{1}{2}(\ln \frac{4}{3} - 5)$$

$$= -2.36 \text{ (3 s.f.)}$$

b  $3^x = 5^{1-x}$

$$x \ln 3 = (1-x) \ln 5$$

$$x \ln 3 + x \ln 5 = \ln 5$$

$$x(\ln 3 + \ln 5) = \ln 5$$

$$x = \frac{\ln 5}{(\ln 3 + \ln 5)}$$

$$= 0.594 \text{ (3 s.f.)}$$

← Take logs of both sides and use  $\log a^n = n \log a$ .

c

$$2 \ln(2x-1) = 1 + \ln 7$$

$$\ln(2x-1)^2 - \ln 7 = 1$$

$$\ln \frac{(2x-1)^2}{7} = 1$$

$$\frac{(2x-1)^2}{7} = e$$

$$(2x-1)^2 = 7e$$

$$2x-1 = \pm \sqrt{7e}$$

$$x = \frac{1}{2}(1 + \sqrt{7e})$$

$$= 2.68$$

←  $\ln(2x-1)^2 = \ln e + \ln 7$   
 $= \ln 7e$

← As  $x > \frac{1}{2}$ ,  $\frac{1}{2}(1 - \sqrt{7e})$  is not applicable.

# Solutionbank C3

## Edexcel AS and A Level Modular Mathematics

Review Exercise  
Exercise A, Question 16

### Question:

Find the exact solutions to the equations

a  $\ln x + \ln 3 = \ln 6$

b  $e^x + 3e^{-x} = 4$  *E*

### Solution:

a  $\ln x + \ln 3 = \ln 6$

so  $\ln 3x = \ln 6$

$$\Rightarrow 3x = 6$$

$$x = 2$$

← Do not make the error of 'removing' the  $\ln$  to give  $x + 3 = 6$ .  
You need to write  $\ln a = \ln b$ .

b

$$e^x + 3e^{-x} = 4$$

$$\Rightarrow e^x + \frac{3}{e^x} = 4$$

← Do not take logs of both sides.  
You need  $e^{ax} = b$  before this strategy is valid.  
 $\ln(e^x + 3e^{-x}) = \ln 4$  cannot be reduced any further.

$$\Rightarrow (e^x)^2 - 4e^x + 3 = 0$$

$$\Rightarrow e^x = 3 \text{ or } e^x = 1$$

← Quadratic in  $e^x$ .

i.e.  $x = \ln 3$  or  $x = \ln 1 = 0$

# Solutionbank C3

## Edexcel AS and A Level Modular Mathematics

Review Exercise  
Exercise A, Question 17

### Question:

The function  $f$  is defined by

$$f : x \rightarrow 3 - \ln(x + 2), \quad x \in \mathbb{R}, x > -2,$$

The graph of  $y = f(x)$  crosses the  $x$ -axis at the point A and crosses the  $y$ -axis at the point B.

- a Find the exact coordinates of A and B.
- b Sketch the graph of  $y = f(x), x > -2$ .

### Solution:

**a**

$$y = 3 - \ln(x+2) \quad x > -2$$

Put  $y = 0$

$$0 = 3 - \ln(x+2)$$

$$\Rightarrow 3 = \ln(x+2)$$

$$e^3 = x+2$$

$$e^3 - 2 = x(\text{exact})$$

So A =  $(e^3 - 2, 0)$

Put  $x = 0$

$$y = 3 - \ln 2$$

So B =  $(0, 3 - \ln 2)$

**b**

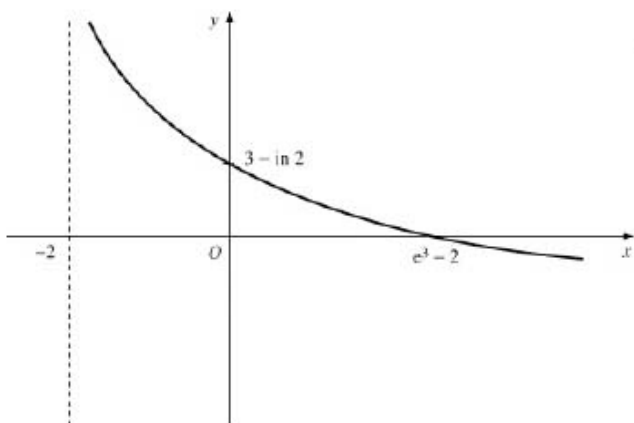

← The curve is a decreasing curve.

# Solutionbank C3

## Edexcel AS and A Level Modular Mathematics

### Review Exercise

#### Exercise A, Question 18

### Question:

The graph of the function

$$f(x) = 144 - 36e^{-2x}, \quad x \in \mathbb{R}$$

has an asymptote  $y = k$ , and crosses the  $x$  and  $y$  axes at A and B respectively, as shown.

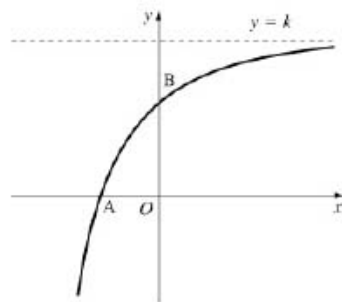

- Write down the value of  $k$  and the  $y$ -coordinate of B.
- Express the  $x$ -coordinate of A in terms of  $\ln 2$ .

### Solution:

- The asymptote is  $y = 144$ , so  $k = 144$ .

← As  $x \rightarrow \infty$ ,  $e^{-2x} \rightarrow 0$  so  
 $144 - 36e^{-2x} \rightarrow 144$ .

The curve crosses the  $y$ -axis where  $x = 0$ ,  
 so  $y = 144 - 36e^0 = 108$ .

The  $y$ -coordinate of B is 108.

- The curve crosses the  $x$ -axis where  $y = 0$

$$\begin{aligned} \Rightarrow 0 &= 144 - 36e^{-2x} \\ \Rightarrow e^{-2x} &= \frac{144}{36} = 4 \\ -2x &= \ln 4 \\ x &= \frac{1}{2} \ln 4 \\ &= -\ln 4^{\frac{1}{2}} \\ &= -\ln 2 \end{aligned}$$



# Solutionbank C3

## Edexcel AS and A Level Modular Mathematics

Review Exercise  
Exercise A, Question 19

### Question:

[Part **d** requires the differentiation of  $e^{ax}$ , see Ch 8]  
The functions  $f$  and  $g$  are defined by

$$f : x \rightarrow 2x + \ln 2, \quad x \in \mathbb{R}$$

$$g : x \rightarrow e^{2x}, \quad x \in \mathbb{R}.$$

**a** Prove that the composite function  $gf$  is

$$gf : x \rightarrow 4e^{4x}, \quad x \in \mathbb{R}.$$

**b** Sketch the curve with equation  $y = gf(x)$ , and show the coordinates of the point where the curve cuts the  $y$ -axis.

**c** Write down the range of  $gf$ .

**d** Find the value of  $x$  for which  $\frac{d}{dx}[gf(x)] = 3$ , giving your answer to 3 significant figures.  $E$

### Solution:

**a**

$$\begin{aligned}
 gf(x) &= g(2x + \ln 2) \\
 &= e^{2(2x + \ln 2)} \\
 &= e^{4x} e^{2 \ln 2} \\
 &= e^{4x} e^{\ln 2^2} \\
 &= 4e^{4x}
 \end{aligned}$$

$$\leftarrow \text{As } e^{a+b} = e^a e^b$$

$$\leftarrow \text{As } p \ln 2 = \ln 2^p \quad \text{and} \\ e^{\ln 2^p} = 2^p$$

$$gf : x \rightarrow 4e^{4x} \quad x \in \mathbb{R}$$

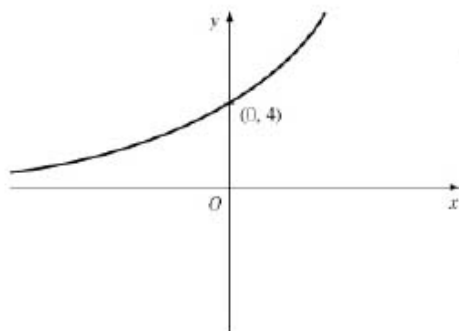
**b**

$$\leftarrow \text{When} \\ x = 0 \\ y = 4e^0 = 4 \times 1 = 4$$

**c** Range:  $gf(x) > 0$ **d**

$$\frac{d}{dx}[gf(x)] = 16e^{4x}$$

$$\text{if } 16e^{4x} = 3$$

$$e^{4x} = \frac{3}{16}$$

$$\Rightarrow 4x = \ln \frac{3}{16}$$

$$x = \frac{1}{4} \ln \frac{3}{16}$$

$$= -0.418 \text{ (3 s.f.)}$$

# Solutionbank C3

## Edexcel AS and A Level Modular Mathematics

### Review Exercise

#### Exercise A, Question 20

### Question:

- a Show that  $e^x - e^{-x} = 4$  can be rewritten in the form  $e^{2x} - 4e^x - 1 = 0$
- b Hence find the exact value of the real solution of  $e^x - e^{-x} = 4$ .
- c For this value of  $x$ , find the exact value of  $e^x + e^{-x}$ .

### Solution:

a

$$\begin{aligned} e^x - e^{-x} &= 4 \\ \Rightarrow e^x - \frac{1}{e^x} &= 4 \\ \Rightarrow (e^x)^2 - 1 &= 4e^x \\ e^{2x} - 4e^x - 1 &= 0 \end{aligned}$$

b

$$\begin{aligned} e^x &= \frac{4 \pm \sqrt{16+4}}{2} \\ &= \frac{4 \pm \sqrt{20}}{2} \\ &= \frac{4 \pm 2\sqrt{5}}{2} \\ &= 2 \pm \sqrt{5} \\ \text{so } e^x &= 2 + \sqrt{5} \\ \Rightarrow x &= \ln(2 + \sqrt{5}) \end{aligned}$$

Use the formula on the quadratic  $y^2 - 4y - 1 = 0$  where  $y = e^x$ .

As  $e^x > 0$ ,  $2 - \sqrt{5}$  not applicable.

c If  $e^x = 2 + \sqrt{5}$

$$\begin{aligned} e^{-x} &= \frac{1}{2 + \sqrt{5}} = \frac{2 - \sqrt{5}}{(2 + \sqrt{5})(2 - \sqrt{5})} \\ &= \frac{2 - \sqrt{5}}{4 - 5} \\ &= \sqrt{5} - 2 \\ \text{so } e^x + e^{-x} &= (2 + \sqrt{5}) + (\sqrt{5} - 2) \\ &= 2\sqrt{5} \end{aligned}$$

# Solutionbank C3

## Edexcel AS and A Level Modular Mathematics

Review Exercise  
Exercise A, Question 21

### Question:

At time  $t = 0$ , a lake is stocked with  $k$  fish. The number,  $n$ , of fish in the lake at time  $t$  days can be represented by the equation

$$n = 3000 + 1450e^{0.04t}$$

- State the value of  $k$ .
- Calculate the increase in the population of fish 3 weeks after stocking the lake.
- Find how many days pass, from the day the lake was stocked, before the number of fish increases to over 7000.

### Solution:

$$n = 3000 + 1450e^{0.04t}$$

- a At  $t = 0$

$$\begin{aligned} n &= 3000 + 1450e^0 \\ &= 4450 \\ \text{so } k &= 4450 \end{aligned}$$

- b At  $t = 21$

$$\begin{aligned} n &= 3000 + 1450e^{0.84} \\ &= 6358.7\dots \end{aligned}$$

So increase in population is  
 $6358 - 4450$   
 $= 1908$  fish

- c

$$\begin{aligned} 7000 &= 3000 + 1450e^{0.04t} \\ \Rightarrow 1450e^{0.04t} &= 4000 \\ e^{0.04t} &= \frac{4000}{1450} \\ 0.04t &= \ln \left[ \frac{4000}{1450} \right] \\ t &= \frac{1}{0.04} \ln \left[ \frac{400}{145} \right] \\ &= 25.3 \end{aligned}$$

So 26 days pass before the population reaches over 7000

# Solutionbank C3

## Edexcel AS and A Level Modular Mathematics

### Review Exercise

#### Exercise A, Question 22

### Question:

A heated metal ball  $S$  is dropped into a liquid. As  $S$  cools, its temperature,  $T^\circ\text{C}$ ,  $t$  minutes after it enters the liquid is given by

$$T = 400e^{-0.05t} + 25, \quad t \geq 0.$$

- Find the temperature of  $S$  as it enters the liquid.
- Find how long  $S$  is in the liquid before its temperature drops to  $300^\circ\text{C}$ . Give your answer to 3 significant figures.
- Find the rate, in  $^\circ\text{C}$  per minute to 3 significant figures, at which the temperature of  $S$  is decreasing at the instant  $t = 50$ .
- With reference to the equation given above, explain why the temperature of  $S$  can never drop to  $20^\circ\text{C}$

*E*

### Solution:

**a**

$$\begin{aligned} \text{Put } t = 0 \Rightarrow T &= 400e^0 + 25 \\ &= 425^\circ\text{C} \end{aligned}$$

**b**  $300 = 400e^{-0.05t} + 25$

$$\Rightarrow 400e^{-0.05t} = 275$$

$$e^{-0.05t} = \frac{275}{400}$$

$$\Rightarrow -0.05t = \ln\left[\frac{275}{400}\right]$$

$$\begin{aligned} t &= \frac{-1}{0.05} \ln\left[\frac{275}{400}\right] \\ &= 7.49 \text{ minutes} \end{aligned}$$

Not using a calculator until the final step ensures that there has been no approximation in the process.

**c**  $\frac{dT}{dt} = 400(-0.05)e^{-0.05t}$

$$\begin{aligned} \text{When } t = 50 \quad \frac{dT}{dt} &= -20e^{-2.5} \\ &= -1.64 \end{aligned}$$

So rate of decrease is  $1.64^\circ\text{C}/\text{minute}$

**d** As  $t \rightarrow \infty$ ,  $400e^{-0.05t} \rightarrow 0$   
so  $T \rightarrow 25$

The temperature can never go below  $25^\circ\text{C}$ , so cannot reach  $20^\circ\text{C}$

# Solutionbank C3

## Edexcel AS and A Level Modular Mathematics

Review Exercise  
Exercise A, Question 23

### Question:

A breeding programme for a particular animal is being monitored. Initially there were  $k$  breeding pairs in the survey.

A suggested model for the number of breeding pairs,  $n$ , after  $t$  years is

$$n = \frac{400}{1 + 9e^{-\frac{1}{9}t}}$$

- a Find the value of  $k$ .  
b Show that the above equation can be written in the form

$$t = 9 \ln \left( \frac{9n}{400 - n} \right)$$

- c Hence, or otherwise, calculate the number of years, according to the model, after which the number of breeding pairs will first exceed 100.

The model predicts that the number of breeding pairs cannot exceed the value  $A$ .

- d Find the value of  $A$ .

### Solution:

$$n = \frac{400}{1 + 9e^{-\frac{1}{9}t}}$$

**a** Initially  $t = 0$ ,  $n = k$

$$\begin{aligned} \text{so } k &= \frac{400}{1 + 9e^0} \\ &= \frac{400}{10} \\ &= 40 \end{aligned}$$

**b**

$$(1 + 9e^{-\frac{1}{9}t})n = 400$$

$$n + 9ne^{-\frac{1}{9}t} = 400$$

$$9ne^{-\frac{1}{9}t} = 400 - n$$

$$e^{-\frac{1}{9}t} = \frac{400 - n}{9n}$$

$$-\frac{1}{9}t = \ln\left[\frac{400 - n}{9n}\right]$$

$$\frac{1}{9}t = -\ln\left[\frac{400 - n}{9n}\right]$$

$$= \ln\left[\frac{400 - n}{9n}\right]^{-1}$$

$$t = 9 \ln\left[\frac{9n}{400 - n}\right]$$

**c** For

$$\begin{aligned} n = 100, t &= 9 \ln\left[\frac{900}{300}\right] \\ &= 9.88\dots \end{aligned}$$

so it takes 10 years

**d** Using the original equation with  $t \rightarrow \infty$

$$\begin{aligned} n \rightarrow \frac{400}{1 + 0} &= 400 \\ A &= 400 \end{aligned}$$

# Solutionbank C3

## Edexcel AS and A Level Modular Mathematics

Review Exercise  
Exercise A, Question 24

### Question:

$$f(x) = x^3 - \frac{1}{x} - 2, \quad x \neq 0.$$

- a Show that the equation  $f(x) = 0$  has a root between 1 and 2.  
An approximation for this root is found using the iteration formula

$$x_{n+1} = \left(2 + \frac{1}{x_n}\right)^{\frac{1}{3}}, \text{ with } x_0 = 1.5.$$

- b By calculating the values of  $x_1, x_2, x_3$  and  $x_4$  find an approximation to this root, giving your answer to 3 decimal places.  
c By considering the change of sign of  $f(x)$  in a suitable interval, verify that your answer to part b is correct to 3 decimal places. E

### Solution:

a

$$f(1) = 1 - 1 - 2 = -2$$

$$f(2) = 8 - \frac{1}{2} - 2 = 5\frac{1}{2}$$

← There is a change of sign and curve is continuous so there must be at least one root between 1 and 2.

b

$$x_1 = 1.3867\dots$$

$$x_2 = 1.3961\dots$$

$$x_3 = 1.3953\dots$$

$$x_4 = 1.3953\dots$$

← As the values oscillate and  $x_3$  and  $x_4$  are the same to 4 d.p., a 3 d.p. answer can be given.

c approximation to the root is 1.395 (3 d.p.)  
Choosing [1.3945, 1.3955]

← You need to choose this interval or tighter, but there needs to be a sign change.

$$f(1.3945) = -0.0053\dots$$

$$f(1.3955) = +0.0010\dots$$

← As there is a change of sign, the root lies between 1.3945 and 1.3955.

root lies between 1.3945 and 1.3955 so 1.395 is an approximation to the root to 3 d.p.



# Solutionbank C3

## Edexcel AS and A Level Modular Mathematics

Review Exercise  
Exercise A, Question 25

### Question:

- a By sketching the graphs of  $y = -x$  and  $y = \ln x, x > 0$ , on the same axes, show that the solution to the equation  $x + \ln x = 0$  lies between 0 and 1.
- b Show that  $x + \ln x = 0$  may be written in the form  $x = \frac{(2x - \ln x)}{3}$ .
- c Use the iterative formula  
$$x_{n+1} = \frac{(2x_n - \ln x_n)}{3}, \quad x_0 = 1,$$
to find the solution of  $x + \ln x = 0$  correct to 5 decimal places.

### Solution:

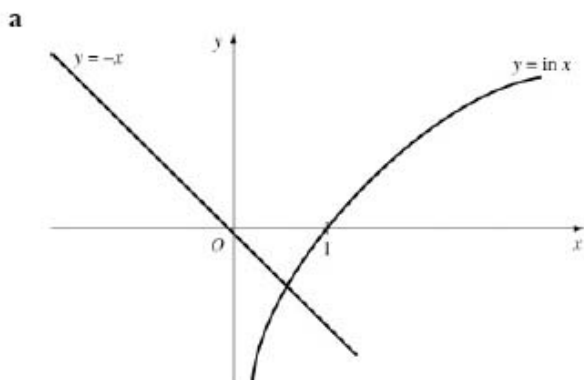

$y = -x$  meets  $y = \ln x$  where  $-x = \ln x$  i.e. where  $x + \ln x = 0$   
 It is clear from the diagram that the solution lies between 0 and 1.

**b**

$$x = \frac{(2x - \ln x)}{3}$$

$$\Rightarrow 3x = 2x - \ln x$$

$$\Rightarrow x + \ln x = 0$$

← Arrangements of  $x + \ln x = 0$  such as  
 $x = -\ln x$   
 $x = e^{-2x}$   
 do not lead to useful iterative processes.

**c**

$$x_1 = 0.666667(6 \text{ d.p.})$$

$$x_2 = 0.579599$$

$$x_3 = 0.568206$$

$$x_4 = 0.567228$$

$$x_5 = 0.567150$$

$$x_6 = 0.567144$$

$$x_7 = 0.567143$$

$$x_8 = 0.567143$$

solution is 0.56714 (5 d.p.)

← You can check by evaluating  $f(0.567135)$  and  $f(0.567145)$  where  $f(x) = x + \ln x$ .

# Solutionbank C3

## Edexcel AS and A Level Modular Mathematics

Review Exercise  
Exercise A, Question 26

### Question:

- a Show that the equation  $e^{2x} - 8x = 0$  has a root  $k$  between  $x = 1$  and  $x = 2$ .  
The iterative formula

$$x_n = \frac{1}{2} \ln 8x, \quad x_0 = 1.2,$$

is used to find an approximation for  $k$

- b Calculate the values of  $x_1, x_2$  and  $x_3$ , giving your answers to 3 decimal places.  
c Show that, to 3 decimal places,  $k = 1.077$ .  
d Deduce the value, to 2 decimal places, of one of the roots of  $e^x = 4x$ .

### Solution:

a

$$f(x) = e^{2x} - 8x$$

$$f(1) = -0.6109\dots$$

$$f(2) = 38.598\dots$$

← Change of sign implies a root between 1 and 2.

b

$$x_1 = 1.131 \text{ (3 d.p.)}$$

$$x_2 = 1.101 \text{ (3 d.p.)}$$

$$x_3 = 1.088 \text{ (3 d.p.)}$$

c

$$f(1.0765) = -0.0013\dots$$

$$f(1.0775) = +0.0789\dots$$

$$1.0765 < 1.077 < 1.0775$$

change of sign shows root lies between the two  $x$  values 1.0765 and 1.0775 so  $k = 1.077$  (3 d.p.)

d Put  $p = 2x$

then  $e^{2x} - 8x = 0$  becomes  $e^p - 4p = 0$

so root of  $e^p = 4p$

is  $p = 2x$

$$= 2 \times 1.077$$

$$= 2.154$$

$$= 2.15 \text{ (2 d.p.)}$$

# Solutionbank C3

## Edexcel AS and A Level Modular Mathematics

Review Exercise  
Exercise A, Question 27

### Question:

The curve  $C$  has equation  $y = x^5 - 1$ . The tangent to  $C$  at the point  $P(-1, -2)$  meets the curve again at the point  $Q$ , whose  $x$ -coordinate is  $k$ .

- a Show that  $k$  is a root of the equation  $x^5 - 5x - 4 = 0$ .  
b Show that  $x^5 - 5x - 4 = 0$  can be rearranged in the form

$$x = \sqrt[4]{5 + \frac{4}{x}}.$$

The iterative formula

$$x_{n+1} = \sqrt[4]{5 + \frac{4}{x_n}}, \quad x_0 = 1.5,$$

is used to find an approximation for  $k$ .

- c Write down the values of  $x_1, x_2, x_3$  and  $x_4$ , giving your answers to 5 significant figures.  
d Show that  $k = 1.6506$  correct to 5 significant figures.

### Solution:

$$y = x^5 - 1$$

**a**  $\frac{dy}{dx} = 5x^4$

At the point  $(-1, -2)$  the gradient of the tangent is  $5(-1)^4 = 5$

Equation of tangent is  $y + 2 = 5(x + 1)$

i.e.  $y = 5x + 3$

Use  $y - y_1 = m(x - x_1)$

tangent meets the curve where

$$5x + 3 = x^5 - 1$$

$$\Rightarrow x^5 - 5x - 4 = 0$$

**b**

$$x^5 = 5x + 4$$

$$\Rightarrow x^4 = 5 + \frac{4}{x}$$

$$\Rightarrow x = \sqrt[4]{\left(5 + \frac{4}{x}\right)}$$

**c**

$$x_1 = 1.6640 \text{ (5 s.f.)}$$

$$x_2 = 1.6495$$

$$x_3 = 1.6507$$

$$x_4 = 1.6506$$

**d**

$$f(1.65055) = -0.0025\dots$$

$$f(1.65065) = +0.00066\dots$$



Evaluate  $f(1.65055)$  and  $f(1.65065)$  where  $f(x) = x^5 - 5x - 4$

Continued iteration is fine here as this is an oscillating set of values and convergence is rapid.

As there is a change of sign the root lies between 1.65055 and 1.65065 so  $k = 1.6506$  (5 s.f.)

# Solutionbank C3

## Edexcel AS and A Level Modular Mathematics

### Review Exercise

#### Exercise A, Question 28

### Question:

$$f(x) = 2x^3 - x - 4.$$

- a Show that the equation  $f(x) = 0$  can be written as

$$x = \sqrt{\left(\frac{2}{x} + \frac{1}{2}\right)}.$$

The equation  $2x^3 - x - 4 = 0$  has a root between 1.35 and 1.4.

- b Use the iteration formula

$$x_{n+1} = \sqrt{\left(\frac{2}{x_n} + \frac{1}{2}\right)},$$

with  $x_0 = 1.35$ , to find, to 2 decimal places, the value of  $x_1, x_2$  and  $x_3$ .

The only real root of  $f(x) = 0$  is  $\alpha$ .

- c By choosing a suitable interval, prove that  $\alpha = 1.392$ , to 3 decimal places. E

### Solution:

a

$$2x^3 - x - 4 = 0$$

$$\Rightarrow 2x^3 = x + 4$$

$$\Rightarrow x^2 = \frac{x+4}{2x} = \frac{1}{2} + \frac{2}{x}$$

$$\Rightarrow x = \sqrt{\left(\frac{2}{x} + \frac{1}{2}\right)}$$

b

$$x_{n+1} = \sqrt{\left(\frac{2}{x_n} + \frac{1}{2}\right)} \quad x_0 = 1.35$$

$$x_1 = 1.41 \text{ (2 d.p.)}$$

$$x_2 = 1.39 \text{ (2 d.p.)}$$

$$x_3 = 1.39 \text{ (2 d.p.)}$$

- c Consider the interval  $[1.3915, 1.3925]$

$$f(1.3915) = -0.00285\dots$$

$$f(1.3925) = +0.00777\dots$$

as there is a change of sign in the interval and  $f(x)$  is continuous, the root lies in the interval so  $\alpha = 1.392$  (3 d.p.)

# Solutionbank C3

## Edexcel AS and A Level Modular Mathematics

Review Exercise  
Exercise A, Question 29

### Question:

The function  $f$  is defined by

$$f : x \rightarrow -5 + 4e^{2x}, \quad x \in \mathbb{R}, \quad x > 0.$$

a Show that the inverse function of  $f$  is defined by

$$f^{-1} : x \rightarrow \frac{1}{2} \ln \left( \frac{x+5}{4} \right),$$

and write down the domain of  $f^{-1}$ .

b Write down the range of  $f^{-1}$ .

The graph of  $y = \frac{1}{2}x$  crosses the graph of  $y = f^{-1}(x)$  at  $x = k$ .

The iterative formula

$$x_{n+1} = \ln \left( \frac{x_n + 5}{4} \right), \quad x_0 = 0.3,$$

is used to find to find an approximation for  $k$ .

- c Calculate the values of  $x_1$  and  $x_2$ , giving your answers to 4 decimal places.
- d Continue the iterative process until you have two values which are the same to 4 decimal places.
- e Prove that this value does give  $k$ , correct to 4 decimal places.

### Solution:

$$f : x \rightarrow -5 + 4e^{2x} \quad x > 0$$

a Let

$$y = -5 + 4e^{2x}$$

$$4e^{2x} = y + 5$$

$$e^{2x} = \frac{y+5}{4}$$

$$2x = \ln\left[\frac{y+5}{4}\right]$$

$$x = \frac{1}{2} \ln\left[\frac{y+5}{4}\right]$$

$$\text{so } f^{-1} : x \rightarrow \frac{1}{2} \ln\left[\frac{x+5}{4}\right]$$

domain of  $f^{-1}$  is  $x > -1$

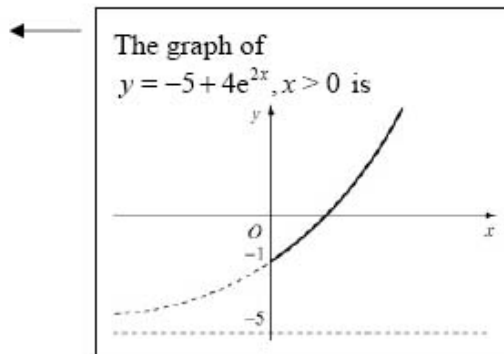

This is the range of  $f$ .

This is the domain of  $f$ .

b range of  $f^{-1}$  is  $f^{-1}(x) > 0$

c

$$x_1 = 0.2814$$

$$x_2 = 0.2779$$

d

$$x_3 = 0.2772$$

$$x_4 = 0.2771$$

$$x_5 = 0.2771$$

As this is a decreasing set of values, you cannot be sure that this does give  $k$  correct to 4 d.p.

e

$$f(0.27705) = -2.2 \dots \times 10^{-5}$$

$$f(0.27715) = +5.8 \times \dots \times 10^{-5}$$

$$k = 0.2771 \text{ (4 d.p.)}$$

Evaluate  $f(0.27705)$  and  $f(0.27715)$  where

$$f(x) = x - \ln\left(\frac{x+5}{4}\right)$$

Change of sign indicates the root lies between 0.27705 and 0.27715.



# Solutionbank C3

## Edexcel AS and A Level Modular Mathematics

Review Exercise  
Exercise A, Question 30

### Question:

The graph of the function  $f$ , defined by

$$f : x \rightarrow \frac{1}{1+x^2}, \quad x \in \mathbb{R}, \quad x \geq 0,$$

is shown.

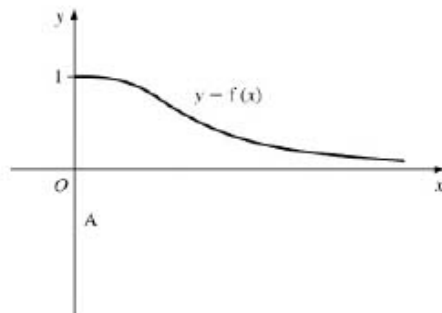

- a Copy the sketch and add to it the graph of  $y = f^{-1}(x)$ , showing the coordinates of the point where it meets the  $x$ -axis.

The two curves meet in the point A, with  $x$ -coordinate  $k$ .

- b Explain why  $k$  is a solution of the equation  $x = \frac{1}{1+x^2}$ .

The iterative formula

$$x_{n+1} = \frac{1}{1+x_n^2}, \quad x_0 = 0.7$$

is used to find an approximation of  $k$ .

- c Calculate the values of  $x_1, x_2, x_3$  and  $x_4$ , giving your answers to 4 decimal places.
- d Show that  $k = 0.682$ , correct to 3 decimal places.

### Solution:

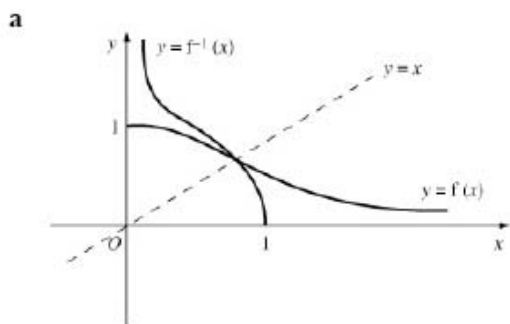

**b**  $y = f^{-1}(x)$  is the reflection of  $y = f(x)$  in  $y = x$   
 So the point A lies on  $y = f(x)$  and  $y = x$

where they meet  $x = \frac{1}{1+x^2}$

It also lies on  $y = f^{-1}(x)$ .

- c**
- $x_1 = 0.6711$  (4 d.p.)
  - $x_2 = 0.6895$
  - $x_3 = 0.6778$
  - $x_4 = 0.6852$

**d**

$f(0.6815) = -0.00135\dots$   
 $f(0.6825) = +0.00028\dots$

Where  $f(x) = x - \frac{1}{1+x^2}$ .

as change of sign root lies between 0.6815 and 0.6825  
 i.e.  $k = 0.682$  (3 d.p.)

# Solutionbank C3

## Edexcel AS and A Level Modular Mathematics

### 2 Review Exercise

#### Exercise A, Question 1

#### Question:

- a On the same set of axes sketch the graphs of  $y = |2x - 1|$  and  $y = |x - k|$ ,  $k > 1$ .
- b Find, in terms of  $k$ , the values of  $x$  for which  $|2x - 1| = |x - k|$ .

#### Solution:

a

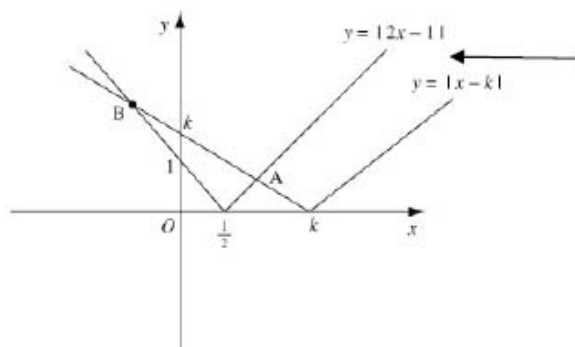

For  $y = |2x - 1|$  draw  $y = 2x - 1$  and reflect part below  $x$ -axis in the  $x$ -axis. For  $y = |x - k|$ , intersects  $x$ -axis at  $(k, 0)$  where  $k > 1$  and gradient is 1, whereas the other line has gradient 2.

b For point A

$$\begin{aligned} 2x - 1 &= -(x - k) \\ \Rightarrow 3x &= 1 + k \\ x &= \frac{1 + k}{3} \end{aligned}$$

The line  $|x - k|$  has been reflected so equation is  $y = -(x - k)$ .

For point B

$$\begin{aligned} -(2x - 1) &= -(x - k) \\ \Rightarrow -2x + 1 &= -x + k \\ x &= 1 - k \end{aligned}$$

Both lines have been reflected.

As  $k > 0$ , this value is negative, which agrees with diagram.

# Solutionbank C3

## Edexcel AS and A Level Modular Mathematics

2 Review Exercise  
Exercise A, Question 2

### Question:

- a Sketch the graph of  $y = |3x + 2| - 4$ , showing the coordinates of the points of intersection of the graph with the axes.
- b Find the values of  $x$  for which  $|3x + 2| = 4 + x$ .

### Solution:

**a**

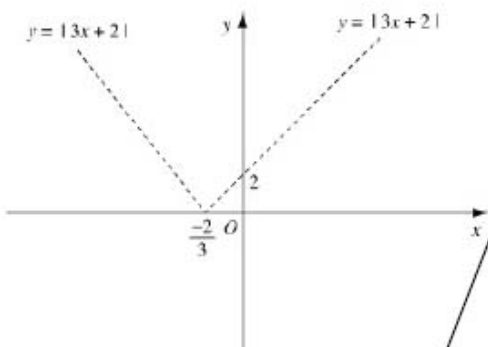

First draw  $y = |3x + 2|$  and then translate by 4 units in negative  $y$ -direction.

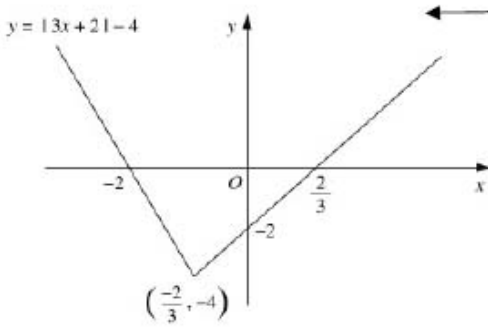

Meets  $x$ -axis where

**i**

$$y = 3x + 2 - 4 = 0$$

$$\Rightarrow 3x = 2$$

$$x = \frac{2}{3}$$

**ii**

$$y = -3x - 2 - 4 = 0$$

$$\Rightarrow 3x = -6$$

$$x = -2$$

**b**

$$|3x + 2| = 4 + x$$

$$|3x + 2| - 4 = x$$

The values of  $x$  are the  $x$ -coordinates of the intersections of  $y = x$  and  $y = |3x + 2| - 4$ .

So

**i**

$$3x + 2 - 4 = x$$

$$\Rightarrow 2x = 2$$

$$x = 1$$

Alternatively, you could solve  $(3x + 2)^2 = (4 + x)^2$ .

**ii**

$$-3x - 2 - 4 = x$$

$$\Rightarrow 4x = -6$$

$$x = -1\frac{1}{2}$$

# Solutionbank C3

## Edexcel AS and A Level Modular Mathematics

### 2 Review Exercise

#### Exercise A, Question 3

#### Question:

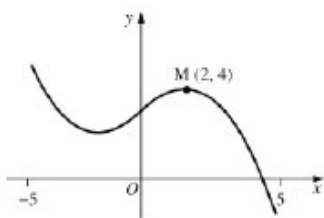

The figure shows the graph of  $y = f(x)$ ,  $-5 \leq x \leq 5$ .

The point  $M(2, 4)$  is the maximum turning point of the graph.

Sketch, on separate diagrams, the graphs of

- a  $y = f(x) + 3$
- b  $y = |f(x)|$
- c  $y = f(|x|)$ .

Show on each graph the coordinates of any maximum turning points.

#### Solution:

**a**

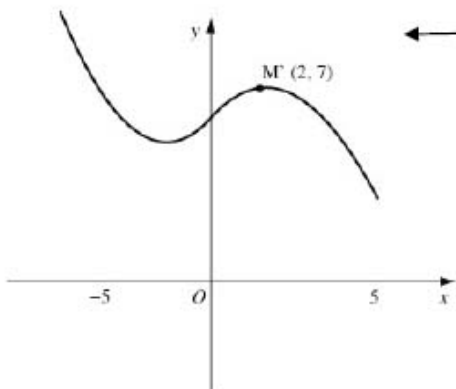

← Translation of +3 in the y direction.

**b**

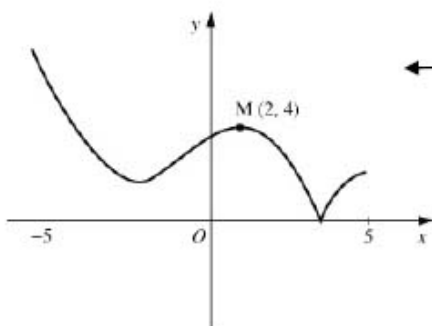

← For  $y \geq 0$ , curve is  $y = f(x)$ .  
For  $y < 0$ , reflect in  $x$ -axis.

**c**

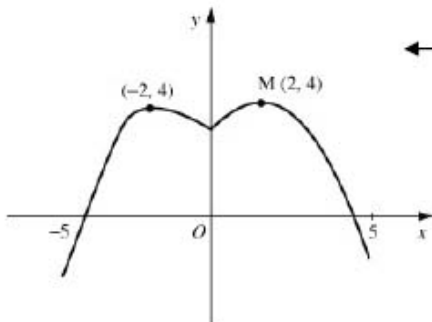

← For  $x < 0$   
 $f | x| = f(-x)$   
so draw  $y = f(x)$   
for  $x \geq 0$ , and then reflect this in  
 $x = 0$ .

# Solutionbank C3

## Edexcel AS and A Level Modular Mathematics

### 2 Review Exercise

#### Exercise A, Question 4

#### Question:

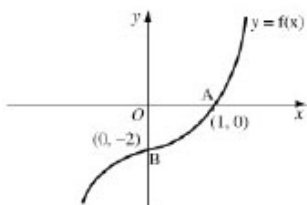

The diagram shows a sketch of the graph of the increasing function  $f$ . The curve crosses the  $x$ -axis at the point  $A(1, 0)$  and the  $y$ -axis at the point  $B(0, -2)$ . On separate diagrams, sketch the graph of:

- a  $y = f^{-1}(x)$
- b  $y = f(|x|)$
- c  $y = f(2x) + 1$
- d  $y = 3f(x-1)$ .

In each case, show the images of the points  $A$  and  $B$ .

#### Solution:



**a**

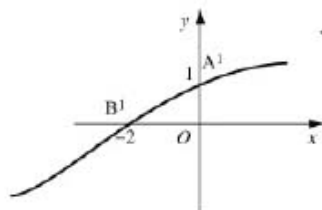

← Reflect  $y = f(x)$  in  $y = x$ .  
 $(1, 0) \rightarrow (0, 1)$   
 $(0, -2) \rightarrow (-2, 0)$

**b**

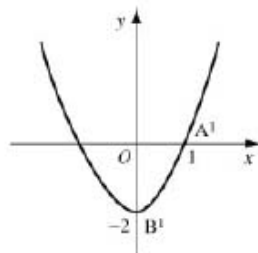

← Draw  $y = f(x), x \geq 0$   
 Reflect this in  $y$ -axis.

**c**

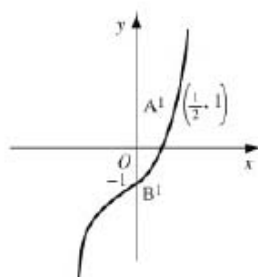

← Sketch  $y = f(x)$  in  $x$ -axis with scale factor  $\frac{1}{2}$ , and translate in the  $y$  direction by 1 unit.

**d**

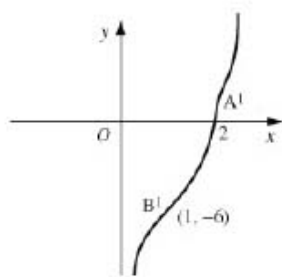

← Translate by +1 in the  $x$  direction and stretch in the  $y$  direction with scale factor 3.

# Solutionbank C3

## Edexcel AS and A Level Modular Mathematics

### 2 Review Exercise Exercise A, Question 5

#### Question:

For the positive constant  $k$ , where  $k > 1$  the functions  $f$  and  $g$  are defined by

$$f : x \rightarrow \ln(x+k), x > -k,$$

$$g : x \rightarrow |2x-k|, x \in \mathbb{R}$$

- Sketch, on the same set of axes, the graphs of  $f$  and  $g$ . Give the coordinates of points where the graphs meet the axes.
- Write down the range of  $f$ .
- Find, in terms of  $k$ ,  $fg\left(\frac{k}{4}\right)$ .

The curve  $C$  has equation  $y = f(x)$ . The tangent to  $C$  at the point with  $x$ -coordinate 3 is parallel to the line with equation  $9y = 2x + 1$ .

- Find the value of  $k$ . *E*

#### Solution:

a

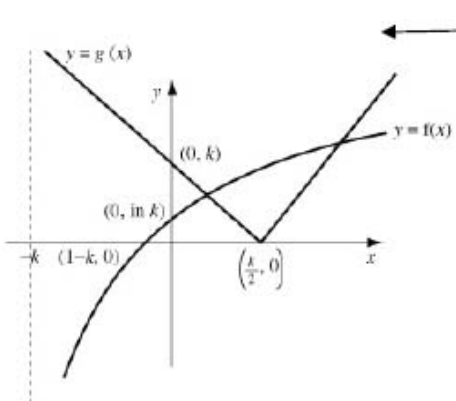

Graph is for  $k > 1$   $y = f(x)$  has asymptote  $x = -k$ .  
 It meets the  $x$ -axis where  $\ln(x+k) = 0$   
 $\Rightarrow x+k = 1$   
 $\Rightarrow x = 1-k$   
 It meets the  $y$ -axis where  $x = 0$ , i.e.  $y = \ln k$ .  
 $y = g(x)$  is v-shaped passing through  $(\frac{k}{2}, 0)$  and  $(0, k)$ .

b

Range of  $f$  is  $f(x) \in \mathbb{R}$

$f$  is an increasing function.

c

$$\begin{aligned} fg\left(\frac{k}{4}\right) &= f\left(-\frac{k}{2}\right) \\ &= f\left(\frac{k}{2}\right) \\ &= \ln\left(\frac{3k}{2}\right) \end{aligned}$$

d

$$y = \ln(x+k)$$

$$\frac{dy}{dx} = \frac{1}{x+k}$$

$$\text{So when } x = 3 \quad \frac{1}{3+k} = \frac{2}{9}$$

Gradient of  $9y = 2x + 1$  is  $\frac{2}{9}$ .

$$\Rightarrow 7 = 6 + 2k$$

$$\Rightarrow 2k = 1$$

$$k = \frac{1}{2}$$

# Solutionbank C3

## Edexcel AS and A Level Modular Mathematics

### 2 Review Exercise

#### Exercise A, Question 6

#### Question:

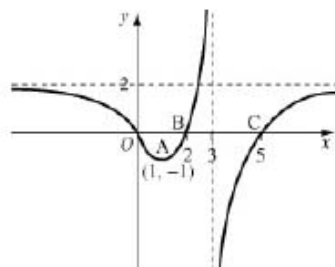

The diagram shows a sketch of the graph of  $y = f(x)$ .

The curve has a minimum at the point  $A(1, -1)$ , passes through  $x$ -axis at the origin, and the points  $B(2, 0)$  and  $C(5, 0)$ ; the asymptotes have equations  $x = 3$  and  $y = 2$ .

- a Sketch, on separate axes, the graph of
  - i  $y = |f(x)|$
  - ii  $y = -f(x+1)$
  - iii  $y = f(-2x)$
 in each case, showing the images of the points  $A$ ,  $B$  and  $C$ .
- b State the number of solutions to the equation
  - i  $3|f(x)| = 2$
  - ii  $2|f(x)| = 3$ .

#### Solution:

**a i**

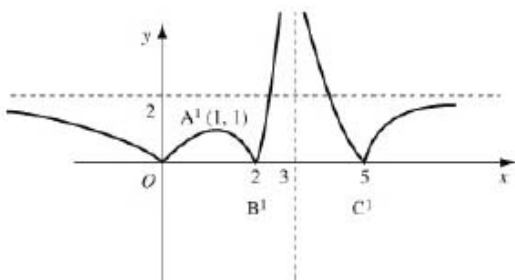

All parts of curve  $y = f(x)$  below  $x$ -axis are reflected in  $x$ -axis.  
 $A \rightarrow (1, 1)$   
 $B$  and  $C$  do not move.

**ii**

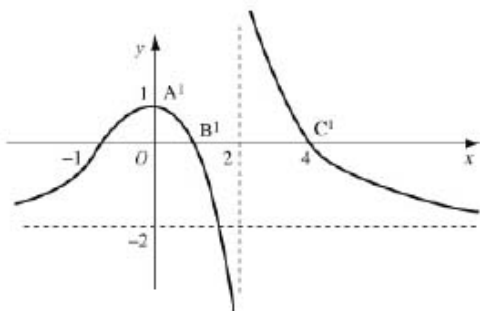

Translate by  $-1$  in the  $x$  direction and reflect in the  $x$  - axis.

**iii**

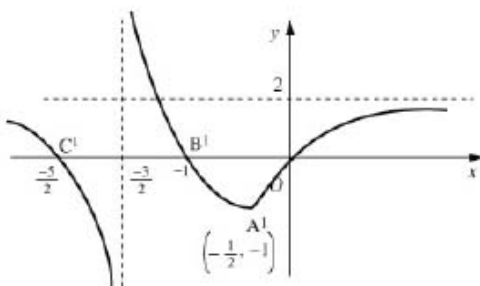

Stretch in the  $x$  direction with scale factor  $-\frac{1}{2}$  (or stretch in the  $x$  direction with scale factor  $\frac{1}{2}$  and reflect in the  $y$ -axis).

**b i**

$3|f(x)| = 2 \Rightarrow |f(x)| = \frac{2}{3}$   
 number of solutions is 6

**ii**  $2|f(x)| = 3 \Rightarrow |f(x)| = \frac{3}{2}$   
 number of solutions is 4

ie  $2|f(x)| = 3 \Rightarrow |f(x)| = \frac{3}{2}$

Consider graph a i.  
**i** How many times does the line  $y = \frac{2}{3}$  cross the curve?  
 Line is below  $A'$ .  
**ii** Draw the line  $y = \frac{3}{2}$ .

# Solutionbank C3

## Edexcel AS and A Level Modular Mathematics

### 2 Review Exercise

#### Exercise A, Question 7

#### Question:

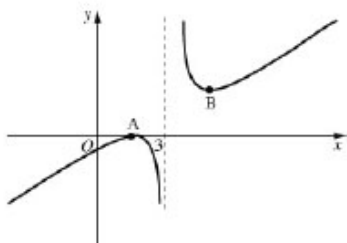

The diagram shows part of the curve  $C$  with equation  $y = f(x)$  where

$$f(x) = \frac{(x-1)^2}{(x-3)}.$$

The points  $A$  and  $B$  are the stationary points of  $C$ .

The line  $x = 3$  is a vertical asymptote to  $C$ .

- Using calculus, find the coordinates of  $A$  and  $B$ .
- Sketch the curve  $C^*$ , with equation  $y = f(-x) + 2$ , showing the coordinates of the images of  $A$  and  $B$ .
- State the equation of the vertical asymptote to  $C^*$ .

#### Solution:

**a**

$$\frac{dy}{dx} = \frac{(x-3)2(x-1) - (x-1)^2(1)}{(x-3)^2}$$

Use the quotient rule.

$$= \frac{(x-1)[2x-6 - (x-1)]}{(x-3)^2}$$

$$= \frac{(x-1)(x-5)}{(x-3)^2}$$

$f(x) = 0 \Rightarrow x = 1$ , so, as a check, you know that the coordinates of A are (1, 0).

$$\frac{dy}{dx} = 0 \Rightarrow x = 1 \text{ or } x = 5$$

Coordinates of A: (1, 0)

B: (5, 8)

$$y = \frac{(5-1)^2}{(5-3)} = \frac{16}{2} = 8$$

**b**

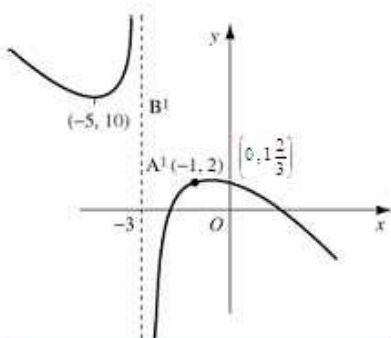

Reflect in the  $y$ -axis and translate by 2 units in the  $y$  direction.

**c**  $x = -3$

# Solutionbank C3

## Edexcel AS and A Level Modular Mathematics

### 2 Review Exercise

#### Exercise A, Question 8

#### Question:

- a On the same set of axes, in the interval  $-\pi < \theta < \pi$ , sketch the graphs of
- $y = \cot \theta$ ,
  - $y = 3 \sin 2\theta$
- b Solve, in the interval  $-\pi < \theta < \pi$ , the equation  $\cot \theta = 3 \sin 2\theta$  giving your answers, in radians, to 3 significant figures where appropriate.

#### Solution:

a

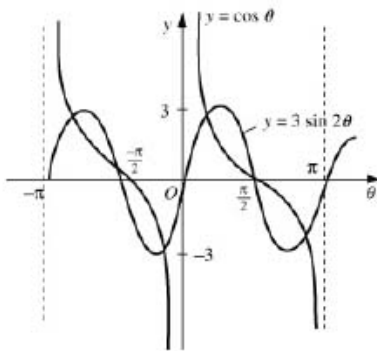

b

$$\begin{aligned} \cot \theta &= 3 \sin 2\theta \\ \Rightarrow \frac{\cos \theta}{\sin \theta} &= 6 \sin \theta \cos \theta \end{aligned}$$

Do not cancel  $\cos \theta$ .

$$\begin{aligned} \Rightarrow \cos \theta (1 - 6 \sin^2 \theta) &= 0 \\ \Rightarrow \cos \theta = 0 \text{ or } \sin \theta &= \pm \sqrt{\frac{1}{6}} \end{aligned}$$

Do not forget  $\pm$  for  $\sin \theta$ .

$$\cos \theta = 0 \Rightarrow \theta = \pm \frac{\pi}{2} = 1.57$$

$$\sin \theta = \pm \sqrt{\frac{1}{6}}$$

$$\theta =$$

$$0.421, 2.72, -0.421, -2.72$$

Give values in all 4 quadrants.  
Remember to use the radian mode on your calculator.  
 $\alpha, \pi - \alpha, -\alpha, -\pi + \alpha$



# Solutionbank C3

## Edexcel AS and A Level Modular Mathematics

### 2 Review Exercise

#### Exercise A, Question 9

#### Question:

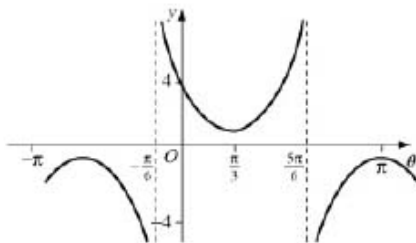

The diagram shows, in the interval  $-\pi \leq \theta \leq \pi$ , the graph of  $y = k \sec(\theta - \alpha)$ .

The curve crosses the  $y$ -axis at the point  $(0, 4)$  and the  $\theta$ -coordinate of its minimum point is  $\pi/3$ .

- State, as a multiple of  $\pi$ , the value of  $\alpha$ .
- Find the value of  $k$ .
- Find the exact values of  $\theta$  at the points where the graph crosses the line  $y = -2\sqrt{2}$ .
- Show that the gradient at the point on the curve with  $\theta$ -coordinate  $\frac{7\pi}{12}$  is  $2\sqrt{2}$ .

#### Solution:

a  $\frac{\pi}{3}$

$y = k \sec \theta$  has minimum on  $y$ -axis.

This curve has been translated by  $\frac{\pi}{3}$   
in the  $x$  direction.

b As  $(0, 4)$  lies on curve

$$\begin{aligned} 4 &= k \sec\left(-\frac{\pi}{3}\right) \\ \Rightarrow 4 &= 2k \\ \Rightarrow k &= 2 \end{aligned}$$

$$\begin{aligned} \cos\left(-\frac{\pi}{3}\right) &= \frac{1}{2} \\ \Rightarrow \sec\left(-\frac{\pi}{3}\right) &= 2 \end{aligned}$$

c Solve

$$\begin{aligned} 2 \sec\left(\theta - \frac{\pi}{3}\right) &= -2\sqrt{2} \\ \Rightarrow \sec\left(\theta - \frac{\pi}{3}\right) &= -\sqrt{2} \\ \Rightarrow \cos\left(\theta - \frac{\pi}{3}\right) &= -\frac{1}{\sqrt{2}} \end{aligned}$$

$$\begin{aligned} \Rightarrow \theta - \frac{\pi}{3} &= -\frac{5\pi}{4}, \frac{3\pi}{4} \\ \theta &= \frac{\pi}{3} - \frac{5\pi}{4}, \frac{\pi}{3} - \frac{3\pi}{4} \\ &= -\frac{11\pi}{12}, -\frac{5\pi}{12} \end{aligned}$$

$\cos^{-1}\left(\frac{-1}{\sqrt{2}}\right)$  gives values in the

2nd and 3rd quadrants.

$$-\frac{4\pi}{3} \leq \theta - \frac{\pi}{3} \leq \frac{2\pi}{3}$$

[ $y = -2\sqrt{2}$  meets the graph  
where  $\theta$  is negative.]

d

$$\begin{aligned} \frac{dy}{d\theta} &= 2 \sec\left(\theta - \frac{\pi}{3}\right) \tan\left(\theta - \frac{\pi}{3}\right) \\ \text{At } \theta &= \frac{7\pi}{12}, \frac{dy}{dx} = 2 \sec\frac{\pi}{4} \tan\frac{\pi}{4} = 2\sqrt{2}(1) = 2\sqrt{2} \end{aligned}$$

# Solutionbank C3

## Edexcel AS and A Level Modular Mathematics

### 2 Review Exercise

#### Exercise A, Question 10

#### Question:

- a Given that  $\sin^2 \theta + \cos^2 \theta = 1$ , show that  $1 + \tan^2 \theta \equiv \sec^2 \theta$ .
- b Solve, for  $0 \leq \theta < 360^\circ$ , the equation  $2 \tan^2 \theta + \sec \theta = 1$ , giving your answers to 1 decimal place. *E*

#### Solution:

a

$$\begin{aligned} \sin^2 \theta + \cos^2 \theta &\equiv 1 \\ \Rightarrow \frac{\sin^2 \theta}{\cos^2 \theta} + \frac{\cos^2 \theta}{\cos^2 \theta} &\equiv \frac{1}{\cos^2 \theta} \\ \Rightarrow \tan^2 \theta + 1 &\equiv \sec^2 \theta \end{aligned}$$

b

$$2 \tan^2 \theta + \sec \theta = 1$$

$$\Rightarrow 2(\sec^2 \theta - 1) + \sec \theta = 1$$

$$\Rightarrow 2 \sec^2 \theta + \sec \theta - 3 = 0$$

$$\Rightarrow (2 \sec \theta + 3)(\sec \theta - 1) = 0$$

$$\Rightarrow \sec \theta = -\frac{3}{2} \quad \text{or} \quad \sec \theta = +1$$

$$\Rightarrow \cos \theta = -\frac{2}{3} \quad \text{or} \quad \cos \theta = +1$$

$$\cos \theta = -\frac{2}{3} \Rightarrow \theta = 131.8^\circ, 228.2^\circ$$

$$\cos \theta = +1 \Rightarrow \theta = 0^\circ$$

Use result in a to form a quadratic in  $\sec \theta$ .

$360^\circ$  not in interval.

# Solutionbank C3

## Edexcel AS and A Level Modular Mathematics

### 2 Review Exercise

#### Exercise A, Question 11

#### Question:

- a Prove that  $\sec^4 \theta - \tan^4 \theta = 1 + 2 \tan^2 \theta$ .
- b Find all the values of  $x$ , in the interval  $0 \leq x \leq 360^\circ$ , for which  $\sec^4 2x = \tan 2x(3 + \tan^3 2x)$ .  
Give your answers correct to 1 decimal place, where appropriate.

#### Solution:

a

$$\begin{aligned} \sec^4 \theta - \tan^4 \theta &= (\sec^2 \theta + \tan^2 \theta)(\sec^2 \theta - \tan^2 \theta) \\ &= (1 + \tan^2 \theta + \tan^2 \theta)(1) \\ &= 1 + 2 \tan^2 \theta \end{aligned}$$

Use  $a^2 - b^2 = (a + b)(a - b)$ .

← Use  $\sec^2 \theta = 1 + \tan^2 \theta$ .

b

$$\begin{aligned} \sec^4 2x &= 3 \tan 2x + \tan^4 2x \\ \Rightarrow \sec^4 2x - \tan^4 2x &= 3 \tan 2x \\ \Rightarrow 1 + 2 \tan^2 2x &= 3 \tan 2x \\ \Rightarrow 2 \tan^2 2x - 3 \tan 2x + 1 &= 0 \\ \Rightarrow (2 \tan 2x - 1)(\tan 2x - 1) &= 0 \\ \tan 2x = \frac{1}{2} \text{ or } \tan 2x &= 1 \\ \tan 2x = 1 \Rightarrow 2x &= 45^\circ, 225^\circ, 405^\circ, 585^\circ \\ x &= 22.5^\circ, 112.5^\circ, 202.5^\circ, 292.5^\circ \\ \tan 2x = \frac{1}{2} \Rightarrow 2x &= 26.6^\circ, 206.6^\circ, 386.6^\circ, 566.6^\circ \\ x &= 13.3^\circ, 103.3^\circ, 193.3^\circ, 283.3^\circ \end{aligned}$$

← Use result in a with  $\theta = 2x$ .

←  $0 \leq x \leq 360^\circ$   
 $\Rightarrow 0 \leq 2x \leq 720^\circ$

# Solutionbank C3

## Edexcel AS and A Level Modular Mathematics

### 2 Review Exercise

#### Exercise A, Question 12

#### Question:

a Prove that

$$\cot \theta - \tan \theta = 2 \cot 2\theta, \theta \neq \frac{n\pi}{2}.$$

b Solve, for  $-\pi < \theta < \pi$ , the equation

$$\cot \theta - \tan \theta = 5,$$

giving your answers to 3 significant figures.

#### Solution:

a

$$\begin{aligned} \text{LHS} &= \cot \theta - \tan \theta \\ &= \frac{\cos \theta}{\sin \theta} - \frac{\sin \theta}{\cos \theta} \\ &= \frac{\cos^2 \theta - \sin^2 \theta}{\sin \theta \cos \theta} \\ &= \frac{\cos 2\theta}{\frac{1}{2} \sin 2\theta} \\ &= 2 \cot 2\theta \end{aligned}$$

b Solve

$$2 \cot 2\theta = 5$$

$$\Rightarrow \cot 2\theta = \frac{5}{2}$$

$$\tan 2\theta = 0.4$$

$$\Rightarrow 2\theta = -5.903, -2.761, 0.3805, \dots, 3.522$$

$$\theta = -2.95, -1.38, 0.190, 1.76 \text{ (3 s.f.)}$$

$\begin{aligned} -\pi &< \theta < \pi \\ -2\pi &< 2\theta < 2\pi \end{aligned}$
---

# Solutionbank C3

## Edexcel AS and A Level Modular Mathematics

### 2 Review Exercise

#### Exercise A, Question 13

#### Question:

- a Solve, in the interval  $0 \leq \theta \leq 2\pi$ ,  $\sec \theta + 2 = \cos \theta + \tan \theta(3 + \sin \theta)$ , giving your answers to 3 significant figures.
- b Solve, in the interval  $0 \leq x \leq 360^\circ$ ,  $\cot^2 x = \operatorname{cosec} x(2 - \operatorname{cosec} x)$ , giving your answers to 1 decimal place.

#### Solution:

a

$$\begin{aligned} \sec \theta + 2 &= \cos \theta + \tan \theta(3 + \sin \theta) \\ \Rightarrow 1 + 2 \cos \theta &= \cos^2 \theta + 3 \sin \theta + \sin^2 \theta \\ \Rightarrow 1 + 2 \cos \theta &= 1 + 3 \sin \theta \\ \Rightarrow 3 \sin \theta &= 2 \cos \theta \\ \Rightarrow \tan \theta &= \frac{2}{3} \\ \Rightarrow \theta &= 0.588, 3.73 \text{ (3 s.f.)} \end{aligned}$$

Multiply by  $\cos \theta$ .  
Use  $\sin^2 \theta + \cos^2 \theta = 1$ .

b

$$\begin{aligned} \cot^2 x &= \operatorname{cosec} x(2 - \operatorname{cosec} x) \\ &= 2 \operatorname{cosec} x - \operatorname{cosec}^2 x \\ \Rightarrow \operatorname{cosec}^2 x - 1 &= 2 \operatorname{cosec} x - \operatorname{cosec}^2 x \\ \Rightarrow 2 \operatorname{cosec}^2 x - 2 \operatorname{cosec} x - 1 &= 0 \\ \Rightarrow \operatorname{cosec} x &= \frac{2 \pm \sqrt{4 + 8}}{4} \\ &= \frac{1 \pm \sqrt{3}}{2} \end{aligned}$$

Use  $1 + \cot^2 x = \operatorname{cosec}^2 x$  to form a quadratic equation in  $\operatorname{cosec} x$ .

$$\sqrt{12} = 2\sqrt{3}$$

As  $\operatorname{cosec} x \geq 1$  or  $\operatorname{cosec} x \leq -1$

$$\operatorname{cosec} x = \frac{1 + \sqrt{3}}{2} = 1.366\dots$$

$$\sin x = 0.732\dots$$

$$x = 47.1^\circ, 132.9^\circ$$

$$-1 \leq \frac{1 - \sqrt{3}}{2} \leq 1 \text{ so invalid.}$$

# Solutionbank C3

## Edexcel AS and A Level Modular Mathematics

### 2 Review Exercise Exercise A, Question 14

#### Question:

Given that

$$y = \arcsin x, -1 \leq x \leq 1 \text{ and } -\frac{\pi}{2} < y < \frac{\pi}{2},$$

- a express  $\arccos x$  in terms of  $y$ .
- b Hence find, in terms of  $\pi$  the value of  $\arcsin x + \arccos x$ .

Given that

$$y = \arccos x, -1 \leq x \leq 1 \text{ and } 0 \leq y \leq \pi,$$

- c sketch, on the same set of axes, the graphs of  $y = \arcsin x$  and  $y = \arccos x$ , making it clear which is which.
- d Explain how your sketches can be used to evaluate  $\arcsin x + \arccos x$ .

#### Solution:

**a**  $y = \arcsin x$

$\Rightarrow \sin y = x$

$x = \cos\left(\frac{\pi}{2} - y\right)$

$\Rightarrow \frac{\pi}{2} - y = \arccos x$

Using  $\sin \theta = \cos\left(\frac{\pi}{2} - \theta\right)$ .

**b**

$$\begin{aligned} \arcsin x + \arccos x &= y + \frac{\pi}{2} - y \\ &= \frac{\pi}{2} \end{aligned}$$

**c**

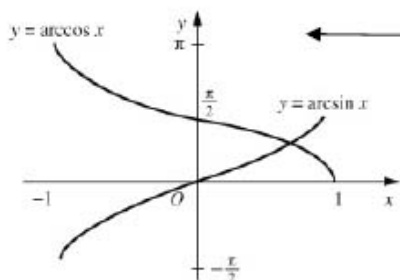

$y = \arccos x$  is a reflection in the line  $y = x$  of  $y = \cos x, 0 \leq x \leq \pi$ .  
 $y = \arcsin x$  is a reflection in the line  $y = x$  of  $y = \sin x, -\frac{\pi}{2} \leq x \leq \frac{\pi}{2}$ .

**d**

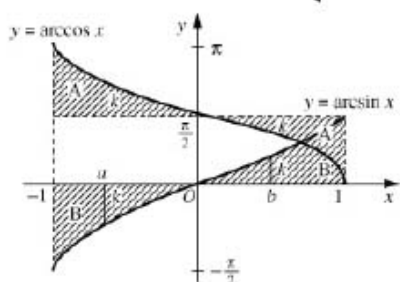

The shaded areas A and B are congruent due to the symmetries of the graphs.  
 Consider  $x = a$ , where  $-1 \leq a < 0$   
 $\arccos x = \frac{\pi}{2} + h$ , see diagram  
 $\arcsin x = -h$   
 $\Rightarrow \arcsin x + \arccos x = \frac{\pi}{2}$   
 Consider  $x = b$ , where  $0 \leq b \leq 1$   
 $\arccos x = \frac{\pi}{2} - k$   
 $\arcsin x = k$   
 $\Rightarrow \arcsin x + \arccos x = \frac{\pi}{2}$



# Solutionbank C3

## Edexcel AS and A Level Modular Mathematics

### 2 Review Exercise

#### Exercise A, Question 15

#### Question:

- a By writing  $\cos 3\theta$  as  $\cos(2\theta + \theta)$ , show that  $\cos 3\theta = 4\cos^3 \theta - 3\cos \theta$ .
- b Given that  $\cos \theta = \frac{\sqrt{2}}{3}$ , find the exact value of  $\sec 3\theta$ .

#### Solution:

a

$$\begin{aligned} \cos(2\theta + \theta) &= \cos 2\theta \cos \theta - \sin 2\theta \sin \theta \\ &= (2\cos^2 \theta - 1)\cos \theta - 2\sin \theta \cos \theta \sin \theta \\ &= 2\cos^3 \theta - \cos \theta - 2\cos \theta(1 - \cos^2 \theta) \\ &= 2\cos^3 \theta - \cos \theta - 2\cos \theta + 2\cos^3 \theta \\ &= 4\cos^3 \theta - 3\cos \theta \end{aligned}$$

Use  $\cos(A + B) = \cos A \cos B - \sin A \sin B$  with  $A = 2\theta, B = \theta$ .

Use  $\sin^2 \theta = 1 - \cos^2 \theta$ .

b

$$\begin{aligned} \cos 3\theta &= 4\left(\frac{\sqrt{2}}{3}\right)^3 - 3\left(\frac{\sqrt{2}}{3}\right) \\ &= \frac{8\sqrt{2}}{27} - \frac{\cancel{3}\sqrt{2}}{\cancel{3}} \\ &= \frac{-19\sqrt{2}}{27} \\ \Rightarrow \sec 3\theta &= \frac{-27}{19\sqrt{2}} = \frac{-27\sqrt{2}}{38} \end{aligned}$$

$$(\sqrt{2})^3 = 2\sqrt{2}$$

# Solutionbank C3

## Edexcel AS and A Level Modular Mathematics

### 2 Review Exercise

#### Exercise A, Question 16

#### Question:

Given that  $\sin(x+30^\circ) = 2\sin(x-60^\circ)$ ,

- a show that  $\tan x = 8+5\sqrt{3}$ .  
 b Hence express  $\tan(x+60^\circ)$  in the form  $a+b\sqrt{3}$ .

#### Solution:

a  $\sin(x+30^\circ) = 2\sin(x-60^\circ)$

$$\Rightarrow \sin x \cos 30^\circ + \cos x \sin 30^\circ = 2\sin x \cos 60^\circ - 2\cos x \sin 60^\circ$$

$$\Rightarrow \frac{\sqrt{3}}{2}\sin x + \frac{1}{2}\cos x = \sin x - \sqrt{3}\cos x$$

$$\Rightarrow \sqrt{3}\sin x + \cos x = 2\sin x - 2\sqrt{3}\cos x$$

$$\Rightarrow (2\sqrt{3}+1)\cos x = (2-\sqrt{3})\sin x$$

$$\Rightarrow \tan x = \frac{2\sqrt{3}+1}{2-\sqrt{3}}$$

$$= \frac{(2\sqrt{3}+1)(2+\sqrt{3})}{(2-\sqrt{3})(2+\sqrt{3})}$$

$$= \frac{4\sqrt{3} + \sqrt{3} + 2 + 6}{1}$$

$$= 8+5\sqrt{3}$$

$$\cos 30^\circ = \sin 60^\circ = \frac{\sqrt{3}}{2}$$

$$\sin 30^\circ = \cos 60^\circ = \frac{1}{2}$$

Use  $\frac{\sin x}{\cos x} = \tan x$ .

Rationalise the denominator.

b

$$\tan(x+60^\circ) = \frac{\tan x + \sqrt{3}}{1 - \sqrt{3}\tan x}$$

$$= \frac{8+6\sqrt{3}}{1-8\sqrt{3}-15}$$

$$= \frac{8+6\sqrt{3}}{-8\sqrt{3}-14} = \frac{-4-3\sqrt{3}}{4\sqrt{3}+7}$$

$$= \frac{-(4+3\sqrt{3})(7-4\sqrt{3})}{(7+4\sqrt{3})(7-4\sqrt{3})}$$

$$= \frac{-[(28-36) + (21\sqrt{3}-16\sqrt{3})]}{1}$$

$$= 8-5\sqrt{3}$$

$$\tan 60^\circ = \sqrt{3}$$

Use a.

# Solutionbank C3

## Edexcel AS and A Level Modular Mathematics

### 2 Review Exercise

#### Exercise A, Question 17

#### Question:

a Given that  $\cos A = \frac{3}{4}$  where  $270^\circ < A < 360^\circ$ , find the exact value of  $\sin 2A$ .

b i Show that

$$\cos\left(2x + \frac{\pi}{3}\right) + \cos\left(2x - \frac{\pi}{3}\right) = \cos 2x$$

Given that

$$y = 3\sin^2 x + \cos\left(2x + \frac{\pi}{3}\right) + \cos\left(2x - \frac{\pi}{3}\right),$$

ii show that  $\frac{dy}{dx} = \sin 2x$  **E**

#### Solution:

a

$$\begin{aligned}\cos A &= \frac{3}{4}, \quad 270^\circ < A < 360^\circ \\ \Rightarrow \sin A &= \frac{-\sqrt{7}}{4} \\ \text{so } \sin 2A &= 2 \sin A \cos A \\ &= -2 \frac{\sqrt{7}}{4} \times \frac{3}{4} \\ &= \frac{-3\sqrt{7}}{8}\end{aligned}$$

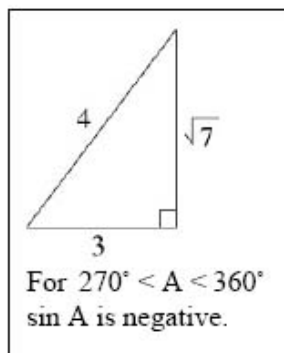

b i

$$\begin{aligned}\cos\left(2x + \frac{\pi}{3}\right) &= \cos 2x \cos \frac{\pi}{3} - \sin 2x \sin \frac{\pi}{3} \\ &= \frac{1}{2} \cos 2x - \frac{\sqrt{3}}{2} \sin 2x \\ \cos\left(2x - \frac{\pi}{3}\right) &= \frac{1}{2} \cos 2x + \frac{\sqrt{3}}{2} \sin 2x \\ \text{so } \cos\left(2x + \frac{\pi}{3}\right) + \cos\left(2x - \frac{\pi}{3}\right) &= \cos 2x \quad \leftarrow \text{Add two results above.}\end{aligned}$$

ii

$$\begin{aligned}y &= 3 \sin^2 x + \cos\left(2x + \frac{\pi}{3}\right) + \cos\left(2x - \frac{\pi}{3}\right) \\ &= 3 \sin^2 x + \cos 2x \\ \frac{dy}{dx} &= 3(2 \sin x \cos x) - 2 \sin 2x \\ &= \sin 2x\end{aligned}$$

Use b i.

# Solutionbank C3

## Edexcel AS and A Level Modular Mathematics

### 2 Review Exercise

#### Exercise A, Question 18

#### Question:

Solve, in the interval  $-180^\circ \leq x < 180^\circ$ , the equations

- a  $\cos 2x + \sin x = 1$   
 b  $\sin x(\cos x + \operatorname{cosec} x) = 2\cos^2 x$ , giving your answers to 1 decimal place.

#### Solution:

a

$$\begin{aligned}\cos 2x + \sin x &= 1 \\ \Rightarrow (1 - \sin^2 x) + \sin x &= 1 \\ \Rightarrow 2\sin^2 x - \sin x &= 0 \\ \sin x(2\sin x - 1) &= 0 \\ \Rightarrow \sin x = 0 \quad \text{or} \quad \sin x &= \frac{1}{2}\end{aligned}$$

← Choose the appropriate form of  $\cos 2x$  to give a quadratic in  $\sin x$ . Do NOT cancel  $\sin x$ , always factorise.

$$\Rightarrow x = -180^\circ, 0^\circ, 30^\circ, 150^\circ$$

b

$$\begin{aligned}\sin x \cos x + \sin x \cdot \frac{1}{\sin x} &= 2\cos^2 x \\ \Rightarrow \sin x \cos x &= 2\cos^2 x - 1 \\ \Rightarrow \frac{1}{2}\sin 2x &= \cos 2x \\ \Rightarrow \tan 2x &= 2 \\ \Rightarrow 2x &= -116.57^\circ, 63.43^\circ \\ x &= -58.3^\circ, 31.7^\circ (1 \text{ d.p.})\end{aligned}$$

$$\begin{aligned}-180^\circ \leq x &< 180^\circ \\ \Rightarrow -360^\circ \leq 2x &< 360^\circ\end{aligned}$$

# Solutionbank C3

## Edexcel AS and A Level Modular Mathematics

### 2 Review Exercise

#### Exercise A, Question 19

#### Question:

- a Prove that  

$$\frac{\sin \theta}{\cos \theta} + \frac{\cos \theta}{\sin \theta} = 2 \operatorname{cosec} 2\theta, \quad \theta \neq 90n^\circ.$$
- b Sketch the graph of  $y = 2 \operatorname{cosec} 2\theta$  for  $0^\circ < \theta < 360^\circ$ .
- c Solve, for  $0^\circ < \theta < 360^\circ$ , the equation  

$$\frac{\sin \theta}{\cos \theta} + \frac{\cos \theta}{\sin \theta} = 3,$$
  
 giving your answers to 1 decimal place. *E*

#### Solution:

a

$$\begin{aligned} \text{LHS} &= \frac{\sin \theta}{\cos \theta} + \frac{\cos \theta}{\sin \theta} \\ &= \frac{\sin^2 \theta + \cos^2 \theta}{\sin \theta \cos \theta} \\ &= \frac{1}{\frac{1}{2} \sin 2\theta} \\ &= 2 \operatorname{cosec} 2\theta \end{aligned}$$

b

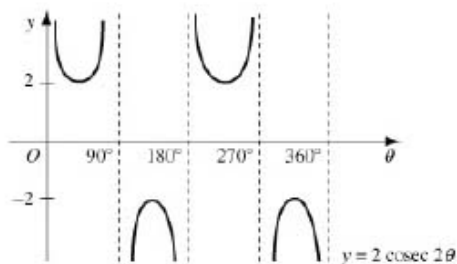

Note that maxima and minima are at  $-2$  and  $+2$  respectively.

c Solve

$$2 \operatorname{cosec} 2\theta = 3$$

$$\text{i.e. } \sin 2\theta = \frac{2}{3}$$

$$\Rightarrow 2\theta = 41.8^\circ, 138.2^\circ, 401.8^\circ, 498.2^\circ$$

$$\theta = 20.9^\circ, 69.1^\circ, 200.9^\circ, 249.1^\circ \text{ (1 d.p.)}$$

$$\begin{aligned} 0^\circ < \theta &< 360^\circ \\ \Rightarrow 0^\circ < 2\theta &< 720^\circ \end{aligned}$$

# Solutionbank C3

## Edexcel AS and A Level Modular Mathematics

2 Review Exercise  
Exercise A, Question 20

### Question:

- a Express  $3\sin x + 2\cos x$  in the form  $R\sin(x + \alpha)$ , where  $R > 0$  and  $0 < \alpha < \frac{\pi}{2}$ .
- b Hence find the greatest value of  $(3\sin x + 2\cos x)^4$ .
- c Solve, for  $0 < x < 2\pi$ , the equation  $3\sin x + 2\cos x = 1$ , giving your answers to 3 decimal places. *E*

### Solution:

**a** Set

$$3 \sin x + 2 \cos x \equiv R \sin(x + \alpha)$$

$$\equiv R \sin x \cos \alpha + R \cos x \sin \alpha$$

$$\Rightarrow R \cos \alpha = 3$$

$$R \sin \alpha = 2$$

$$\Rightarrow \tan \alpha = \frac{2}{3}$$

$$\Rightarrow \alpha = 0.588\dots$$

$$R = \sqrt{13}$$

← Comparing  $\sin x$ .  
Comparing  $\cos x$ .

← Divide.

←  $\alpha$  should be in radians as  
 $0 < \alpha < \frac{\pi}{2}$ .

← For  $R$ :  
either square and add  
 $R^2(\sin^2 \alpha + \cos^2 \alpha) = 3^2 + 2^2$ ,  
 $R > 0$   
or use  $R \cos \alpha = 3$  or  $R \sin \alpha = 2$  with  
 $\alpha$  found above.

$$\Rightarrow 3 \sin x + 2 \cos x = \sqrt{13} \sin(x + 0.588\dots)$$

**b** The maximum value of  $\sqrt{13} \sin(x + 0.588\dots)$  is  $\sqrt{13}$  and occurs when  $\sin(x + 0.588\dots) = 1$  so maximum value of

$$\{\sqrt{13} \sin(x + 0.588\dots)\}^4 = (\sqrt{13})^4$$

$$= 169$$

**c** Solve

$$\sqrt{13} \sin(x + 0.588\dots) = 1$$

$$\Rightarrow \sin(x + 0.588\dots) = \frac{1}{\sqrt{13}}$$

$$\Rightarrow x + 0.588\dots = \pi - 0.2810\dots \quad 2\pi + 0.2810\dots$$

$$= 2.8606, 6.5642\dots$$

$$\Rightarrow x = 2.273, 5.976 \text{ (3 d.p.)}$$

$$0 < x < 2\pi$$

$$\Rightarrow 0.588 < x + 0.588 < 6.87$$

$$\sin^{-1} \frac{1}{\sqrt{13}} = \sin^{-1} 0.277$$

$$= 0.2810\dots$$

is outside above interval for  $x + 0.588$ .



# Solutionbank C3

## Edexcel AS and A Level Modular Mathematics

### 2 Review Exercise

#### Exercise A, Question 21

#### Question:

The point  $P$  lies on the curve with equation  $y = \ln\left(\frac{1}{3}x\right)$ .

The  $x$ -coordinate of  $P$  is 3.

Find an equation of the normal to the curve at the point  $P$  in the form

$y = ax + b$ , where  $a$  and  $b$  are constants.  $E$

#### Solution:

$$y = \ln\left(\frac{1}{3}x\right)$$

$$x = 3, y = \ln 1 = 0, \text{ so } P \equiv (3, 0)$$

$$\frac{dy}{dx} = \frac{1}{x}$$

$$\text{At } P, \text{ gradient of tangent} = \frac{1}{3}$$

$$\text{so gradient of normal} = -3$$

Equation of normal is

$$y - 0 = -3(x - 3)$$

$$y = -3x + 9$$

Remember that  
 $\log ax = \log a + \log x$  in any  
 base

$$\text{so } \frac{d}{dx}(\ln ax) = \frac{d}{dx}(\ln x)$$

Use  $m_1 m_2 = -1$  for  
 perpendicular lines.

# Solutionbank C3

## Edexcel AS and A Level Modular Mathematics

### 2 Review Exercise

#### Exercise A, Question 22

#### Question:

a Differentiate with respect to  $x$

i  $3\sin^2 x + \sec 2x$ ,

ii  $\{x + \ln(2x)\}^3$ ,

Given that  $y = \frac{5x^2 - 10x + 9}{(x-1)^2}$ ,  $x \neq -1$ ,

b show that  $\frac{dy}{dx} = -\frac{8}{(x-1)^3}$  *E*

#### Solution:

a i

$$y = 3\sin^2 x + \sec 2x$$

$$\frac{dy}{dx} = 6\sin x \cos x + 2\sec 2x \tan 2x$$

$$= 3\sin 2x + 2\sec 2x \tan 2x$$

$$\frac{d}{dx}(\sin x)^2 = 2\sin x \cos x$$

$$\frac{d}{dx}\sec ax = a\sec ax \tan ax$$

ii

$$y = \{x + \ln(2x)\}^3$$

$$\frac{dy}{dx} = 3\{x + \ln(2x)\}^2 \left\{1 + \frac{1}{x}\right\}$$

$$y = u^3 \text{ where } u = f(x)$$

$$\frac{dy}{dx} = 3u^2 \frac{du}{dx}$$

Note  $\frac{d}{dx}(\ln ax) = \frac{1}{x}$

b

$$y = \frac{5x^2 - 10x + 9}{(x-1)^2} \quad x \neq -1$$

$$\frac{dy}{dx} = \frac{(x-1)^2(10)(x-1) - (5x^2 - 10x + 9)(2)(x-1)}{(x-1)^4}$$

$$= \frac{10(x^2 - 2x + 1) - 2(5x^2 - 10x + 9)}{(x-1)^3}$$

$$= \frac{10x^2 - 20x + 10 - 10x^2 + 20x - 18}{(x-1)^3}$$

$$= \frac{-8}{(x-1)^3}$$

Use quotient rule

$$u = 5x^2 - 10x + 9$$

$$\frac{du}{dx} = 10x - 10$$

$$v = (x-1)^2$$

$$\frac{dv}{dx} = 2(x-1)$$

Be careful to use brackets and signs appropriately.

# Solutionbank C3

## Edexcel AS and A Level Modular Mathematics

### 2 Review Exercise

#### Exercise A, Question 23

#### Question:

Given that  $y = \ln(1 + e^x)$ ,

a show that when  $x = -\ln 3$ ,  $\frac{dy}{dx} = \frac{1}{4}$

b find the exact value of  $x$  for which  $e^x \frac{dy}{dx} = 6$ .

#### Solution:

$$y = \ln(1 + e^x)$$

a  $\frac{dy}{dx} = \frac{e^x}{1 + e^x}$

when  $x = -\ln 3$

$$\begin{aligned} e^x &= e^{-\ln 3} = e^{\ln 3^{-1}} \\ &= \frac{1}{3} \end{aligned}$$

$$\text{so } \frac{dy}{dx} = \frac{\frac{1}{3}}{1 + \frac{1}{3}} = \frac{\frac{1}{3}}{\frac{4}{3}} = \frac{1}{4}$$

b

$$e^x \frac{dy}{dx} = 6$$

$$\Rightarrow (1 + e^x) \frac{e^x}{1 + e^x} = 6$$

$$\Rightarrow e^x = 6$$

$$\Rightarrow x = \ln 6$$

If  $y = \ln u$  where  $u = f(x)$   
 $\frac{dy}{dx} = \frac{1}{u} \frac{du}{dx}$

Remember that  $e^{\ln k} = k$

# Solutionbank C3

## Edexcel AS and A Level Modular Mathematics

### 2 Review Exercise

#### Exercise A, Question 24

#### Question:

a Differentiate with respect to  $x$

i  $x^2 e^{3x+2}$ ,

ii  $\frac{\cos(2x^3)}{3x}$

b Given that  $x = 4\sin(2y+6)$ , find  $\frac{dy}{dx}$  in terms of  $x$ . **E**

#### Solution:

a i

$$y = x^2 e^{3x+2}$$

$$\frac{dy}{dx} = x^2 \cdot 3e^{3x+2} + 2xe^{3x+2}$$

$$= (3x+2)xe^{3x+2}$$

Use the product rule with

$$u = x^2 \Rightarrow \frac{du}{dx} = 2x$$

$$v = e^{3x+2} \Rightarrow \frac{dv}{dx} = 3e^{3x+2}$$

ii

$$y = \frac{\cos(2x^3)}{3x}$$

$$\frac{dy}{dx} = \frac{3x[-6x^2 \sin(2x^3)] - 3\cos(2x^3)}{9x^2}$$

$$= \frac{-[6x^3 \sin(2x^3) + \cos(2x^3)]}{3x^2}$$

Use the quotient rule with

$$u = \cos(2x^3)$$

$$\Rightarrow \frac{du}{dx} = -6x^2 \sin(2x^3)$$

$$v = 3x \Rightarrow \frac{dv}{dx} = 3$$

b

$$x = 4\sin(2y+6)$$

$$\Rightarrow \frac{dx}{dy} = 8\cos(2y+6)$$

$$\frac{dy}{dx} = \frac{1}{8\cos(2y+6)}$$

$$= \pm \frac{1}{8\sqrt{1-\sin^2(2y+6)}}$$

$$= \pm \frac{1}{8\sqrt{1-\frac{x^2}{16}}}$$

$$= \pm \frac{1}{2\sqrt{16-x^2}}$$

If

$$y = \sin(ax+b)$$

$$\frac{dy}{dx} = a \cos(ax+b)$$

$\frac{dy}{dx}$  is in terms of  $y$ .

Use  $\sin^2 \theta + \cos^2 \theta = 1$

$$\Rightarrow \cos \theta = \pm \sqrt{1-\sin^2 \theta}$$

# Solutionbank C3

## Edexcel AS and A Level Modular Mathematics

### 2 Review Exercise

#### Exercise A, Question 25

#### Question:

Given that  $x = y^2 e^{\sqrt{y}}$ ,

- a find, in terms of  $y$ ,  $\frac{dx}{dy}$
- b show that when  $y = 4$ ,  $\frac{dy}{dx} = \frac{e^{-2}}{12}$ .

#### Solution:

$$x = y^2 e^{\sqrt{y}}$$

a

$$\begin{aligned} \frac{dx}{dy} &= y^2 \frac{1}{2\sqrt{y}} e^{\sqrt{y}} + 2ye^{\sqrt{y}} \\ &= \frac{1}{2} y^{\frac{3}{2}} e^{\sqrt{y}} + 2ye^{\sqrt{y}} \\ &= \frac{y}{2} e^{\sqrt{y}} (\sqrt{y} + 4) \end{aligned}$$

b When  $y = 4$

$$\begin{aligned} \frac{dx}{dy} &= \frac{4}{2} e^2 (2 + 4) \\ &= 12e^2 \\ \text{so } \frac{dy}{dx} &= \frac{1}{12e^2} = \frac{e^{-2}}{12} \end{aligned}$$

Use the product rule with

$$u = y^2 \Rightarrow \frac{du}{dy} = 2y$$

$$v = e^{\sqrt{y}} \Rightarrow \frac{dv}{dy} = \frac{1}{2\sqrt{y}} e^{\sqrt{y}}$$

Remember

If

$$y = e^{f(x)}$$

$$\frac{dy}{dx} = f(x) e^{f(x)}$$

# Solutionbank C3

## Edexcel AS and A Level Modular Mathematics

### 2 Review Exercise

#### Exercise A, Question 26

#### Question:

- a Given that  $y = \sqrt{1+x^2}$ , show that  $\frac{dy}{dx} = \frac{\sqrt{3}}{2}$  when  $x = \sqrt{3}$ .
- b Given that  $y = \ln\{x + \sqrt{1+x^2}\}$ , show that  $\frac{dy}{dx} = \frac{1}{\sqrt{1+x^2}}$ .

#### Solution:

a

$$\begin{aligned} y &= \sqrt{1+x^2} = (1+x^2)^{\frac{1}{2}} \\ \Rightarrow \frac{dy}{dx} &= \frac{1}{2}(1+x^2)^{-\frac{1}{2}} \cdot 2x \\ &= \frac{2x}{2\sqrt{1+x^2}} \\ &= \frac{x}{\sqrt{1+x^2}} \end{aligned}$$

When  $x = \sqrt{3}$

$$\begin{aligned} \frac{dy}{dx} &= \frac{\sqrt{3}}{\sqrt{1+3}} \\ &= \frac{\sqrt{3}}{2} \end{aligned}$$

b

$$\begin{aligned} y &= \ln\{x + \sqrt{1+x^2}\} \\ \frac{dy}{dx} &= \frac{1}{x + \sqrt{1+x^2}} \cdot \frac{d}{dx}\{x + \sqrt{1+x^2}\} \\ &= \frac{1}{x + \sqrt{1+x^2}} \times \left[1 + \frac{x}{\sqrt{1+x^2}}\right] \\ &= \frac{1}{x + \sqrt{1+x^2}} \cdot \frac{(\sqrt{1+x^2} + x)}{\sqrt{1+x^2}} \\ &= \frac{1}{\sqrt{1+x^2}} \end{aligned}$$

Note that this cannot be simplified in particular,  
 $\ln\{x + \sqrt{1+x^2}\} \neq \ln x + \ln \sqrt{1+x^2}$

If  
 $y = \ln f(x)$   
 $\frac{dy}{dx} = \frac{1}{f(x)} f'(x)$

$$\begin{aligned} \frac{d}{dx}(1+x^2)^{\frac{1}{2}} &= \frac{1}{2}(1+x^2)^{-\frac{1}{2}} \cdot 2x \\ &= \frac{x}{\sqrt{1+x^2}} \end{aligned}$$

# Solutionbank C3

## Edexcel AS and A Level Modular Mathematics

### 2 Review Exercise

#### Exercise A, Question 27

#### Question:

Given that  $f(x) = x^2e^{-x}$ ,

- find  $f'(x)$ , using the product rule for differentiation
  - show that  $f''(x) = (x^2 - 4x + 2)e^{-x}$ .
- A curve  $C$  has equation  $y = f(x)$ .
- Find the coordinates of the turning points of  $C$ .
  - Determine the nature of each turning point of the curve  $C$ .

#### Solution:

**a**

$$\begin{aligned} f(x) &= x^2e^{-x} \\ f'(x) &= x^2(-e^{-x}) + 2xe^{-x} \\ &= e^{-x}[-x^2 + 2x] \end{aligned}$$

Use the product rule.

**b**

$$\begin{aligned} f''(x) &= e^{-x}[-2x + 2] - e^{-x}[-x^2 + 2x] \\ &= e^{-x}[x^2 - 4x + 2] \end{aligned}$$

**c** Turning points when  $f'(x) = 0$

$$\begin{aligned} \text{i.e. } x(2-x)e^{-x} &= 0 \\ \Rightarrow x(2-x) &= 0 \quad \text{As } e^{-x} \neq 0 \end{aligned}$$

$$\begin{aligned} \text{So turning points when } x = 0, y = 0 \\ x = 2, y = 4e^{-2} \end{aligned}$$

**d** When  $x = 0, f''(0) = +2 > 0$

So  $(0, 0)$  is a minimum point

$$\text{When } x = 2, f''(2) = e^{-2}(4 - 8 + 2) < 0$$

So  $(2, 4e^{-2})$  is a maximum point

# Solutionbank C3

## Edexcel AS and A Level Modular Mathematics

2 Review Exercise  
Exercise A, Question 28

### Question:

- a Express  $(\sin 2x + \sqrt{3} \cos 2x)$  in the form  $R \sin(2x + k\pi)$ , where  $R > 0$  and  $0 < k < \frac{1}{2}$ .

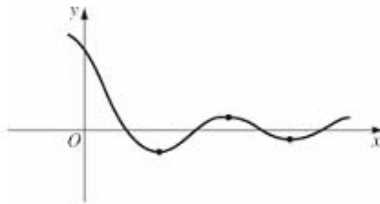

The diagram shows part of the curve with equation

$$y = e^{-2\sqrt{2}x} (\sin 2x + \sqrt{3} \cos 2x).$$

- b Show that the  $x$ -coordinates of the turning points of the curve satisfy the equation

$$\tan\left(2x + \frac{\pi}{3}\right) = \frac{1}{\sqrt{2}}$$

### Solution:



$$\mathbf{a} \quad \sin 2x + \sqrt{3} \cos 2x = R \sin 2x \cos k\pi + R \cos 2x \sin k\pi$$

$$\Rightarrow R \cos k\pi = 1$$

$$R \sin k\pi = \sqrt{3}$$

$$\tan k\pi = \sqrt{3} \Rightarrow k = \frac{1}{3}$$

$$R = 2$$

**b**

$$y = 2e^{-2\sqrt{2}x} \sin\left(2x + \frac{\pi}{3}\right)$$

Use product rule.

$$\frac{dy}{dx} = 2e^{-2\sqrt{2}x} 2 \cos\left(2x + \frac{\pi}{3}\right) - 4\sqrt{2}e^{-2\sqrt{2}x} \sin\left(2x + \frac{\pi}{3}\right)$$

$$= 4e^{-2\sqrt{2}x} \left[ \cos\left(2x + \frac{\pi}{3}\right) - \sqrt{2} \sin\left(2x + \frac{\pi}{3}\right) \right]$$

$$\frac{dy}{dx} = 0$$

$$\Rightarrow \cos\left(2x + \frac{\pi}{3}\right) - \sqrt{2} \sin\left(2x + \frac{\pi}{3}\right) = 0$$

$$\Rightarrow \tan\left(2x + \frac{\pi}{3}\right) = \frac{1}{\sqrt{2}}$$

# Solutionbank C3

## Edexcel AS and A Level Modular Mathematics

### 2 Review Exercise

#### Exercise A, Question 29

#### Question:

The curve  $C$  has equation  $y = x^2\sqrt{\cos x}$ . The point  $P$  on  $C$  has  $x$ -coordinate  $\frac{\pi}{3}$ .

- a Show that the  $y$ -coordinate of  $P$  is  $\frac{\sqrt{2}\pi^2}{18}$ .
- b Show that the gradient of  $C$  at  $P$  is 0.809, to 3 significant figures.

In the interval  $0 < x < \frac{\pi}{2}$ ,  $C$  has a maximum at the point  $A$ .

- c Show that the  $x$ -coordinate,  $k$ , of  $A$  satisfies the equation  $x \tan x = 4$ .

The iterative formula

$$x_{n+1} = \tan^{-1}\left(\frac{4}{x_n}\right), \quad x_0 = 1.25,$$

is used to find an approximation for  $k$ .

- d Find the value of  $k$ , correct to 4 decimal places.

#### Solution:

**a**

$$y = x^2 \sqrt{\cos x}$$

$$x = \frac{\pi}{3} \Rightarrow y = \frac{\pi^2}{9} \sqrt{\frac{1}{2}} = \frac{\sqrt{2}\pi^2}{18}$$

$$\sqrt{\frac{1}{2}} = \frac{1}{\sqrt{2}} = \frac{1 \times \sqrt{2}}{\sqrt{2} \times \sqrt{2}} = \frac{\sqrt{2}}{2}$$

**b**

$$\frac{dy}{dx} = 2x\sqrt{\cos x} + \frac{x^2(-\sin x)}{2\sqrt{\cos x}}$$

When  $x = \frac{\pi}{3}$

Use product rule

$$u = x^2, \frac{du}{dx} = 2x$$

$$v = \sqrt{\cos x}, \frac{dv}{dx} = \frac{1}{2}(\cos x)^{-\frac{1}{2}}(-\sin x)$$

$$\frac{dy}{dx} = \left[ \frac{2\pi}{3} \sqrt{\frac{1}{2}} + \frac{\pi^2}{18} \left( -\frac{\sqrt{3}}{2} \right) \right] \cdot \sqrt{2}$$

$$= 0.8094\dots$$

$$= 0.809 \text{ (3 s.f.)}$$

**c** Setting  $\frac{dy}{dx} = 0$

$$\Rightarrow \frac{4x \cos x - x^2 \sin x}{2\sqrt{\cos x}} = 0$$

$$\Rightarrow 4 \cos x - x \sin x = 0$$

$$\Rightarrow 4 \cos x = x \sin x$$

$$\Rightarrow x \tan x = 4$$

Divide both sides by  $\cos x$ .

Ensure your calculator is in radian mode.

**d**  $x_{n+1} = \tan^{-1}\left(\frac{4}{x_n}\right), x_0 = 1.25$

$$\Rightarrow x_1 = 1.26791\dots$$

$$x_2 = 1.26383\dots$$

$$x_3 = 1.26476\dots$$

$$x_4 = 1.26455\dots$$

$$x_5 = 1.26460\dots$$

$$x_6 = 1.26459\dots$$

$$x_7 = 1.26459\dots$$

$$x_8 = 1.26459\dots$$

$$\Rightarrow x = 1.2646 \text{ (4 d.p.)}$$

You can verify this by considering the sign of  $f(x) = 4 \cos x - x \sin x$  in interval  $[1.26455, 1.26465]$

# Solutionbank C3

## Edexcel AS and A Level Modular Mathematics

### 2 Review Exercise

#### Exercise A, Question 30

#### Question:

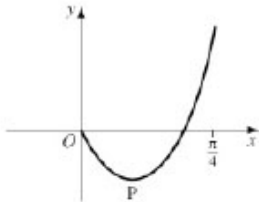

The figure shows part of the curve with equation

$$y = (2x - 1) \tan 2x, \quad 0 \leq x < \frac{\pi}{4}.$$

The curve has a minimum at the point P. The  $x$ -coordinate of P is  $k$ .

**a** Show that  $k$  satisfies the equation

$$4k + \sin 4k - 2 = 0.$$

The iterative formula

$$x_{n+1} = \frac{1}{4}(2 - \sin 4x_n), \quad x_0 = 0.3,$$

is used to find an approximate value for  $k$ .

**b** Calculate the values of  $x_1, x_2, x_3$  and  $x_4$ , giving your answers to 4 decimal places.

**c** Show that  $k = 0.277$ , correct to 3 significant figures. *E*

#### Solution:

**a**

$$y = (2x-1) \tan 2x$$

$$\frac{dy}{dx} = (2x-1)2 \sec^2 2x + 2 \tan 2x$$

$$\text{Setting } \frac{dy}{dx} = 0$$

$$\Rightarrow (2x-1) \sec^2 2x + \tan 2x = 0$$

$$\Rightarrow (2x-1) \frac{1}{\cos^2 2x} + \frac{\sin 2x}{\cos 2x} = 0$$

$$\Rightarrow (2x-1) + \sin 2x \cos 2x = 0$$

$$\Rightarrow 4x - 2 + 2 \sin 2x \cos 2x = 0$$

$$\Rightarrow 4x + \sin 4x - 2 = 0$$

$$\cos 2x \neq 0 \text{ in } 0 \leq x < \frac{\pi}{4}$$

$$\text{Use } \sin 2A = 2 \sin A \cos A \text{ with } A = 2x$$

$$\text{so } k \text{ satisfies } 4x + \sin 4x - 2 = 0$$

**b**

$$x_1 = 0.2670 \text{ (4 d.p.)}$$

$$x_2 = 0.2809 \text{ (4 d.p.)}$$

$$x_3 = 0.2746 \text{ (4 d.p.)}$$

$$x_4 = 0.2774 \text{ (4 d.p.)}$$

Work in radian mode.

**c** Consider  $f(x) = 4x + \sin 4x - 2$ 

$$f(0.2775) = 0.00569\dots$$

$$f(0.2765) = -0.000087\dots$$

so  $k$  is 0.277 (3 s.f.)

As there is a sign change in the interval,  $k$  lies between the two values.